

Low Power JFET Input Operational Amplifiers

These JFET input operational amplifiers are designed for low power applications. They feature high input impedance, low input bias current and low input offset current. Advanced design techniques allow for higher slew rates, gain bandwidth products and output swing.

The commercial and vehicular devices are available in Plastic dual in-line and SOIC packages.

- Low Supply Current: 200 μ A/Amplifier
- Low Input Bias Current: 5.0 pA
- High Gain Bandwidth: 2.0 MHz
- High Slew Rate: 6.0 V/ μ s
- High Input Impedance: $10^{12} \Omega$
- Large Output Voltage Swing: ± 14 V
- Output Short Circuit Protection

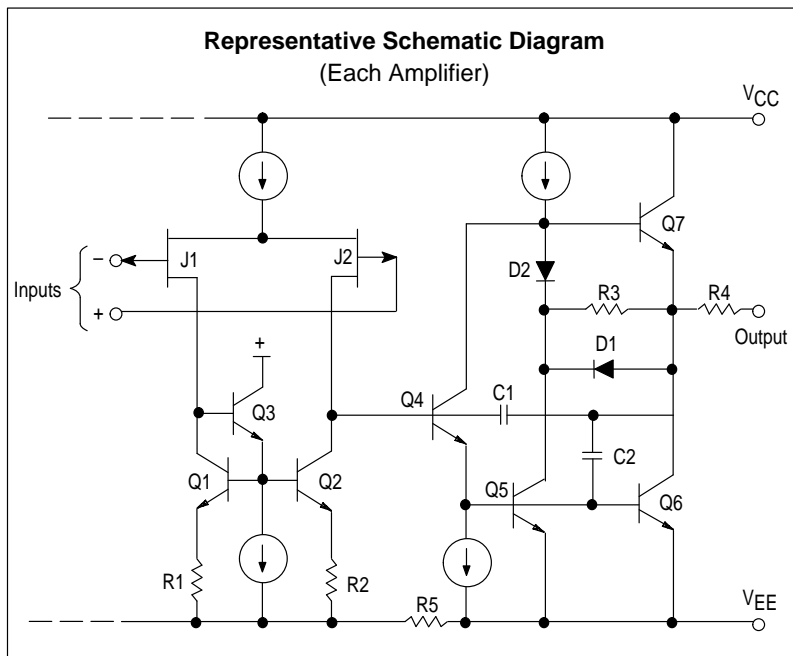

ORDERING INFORMATION

Op Amp Function	Device	Operating Temperature Range	Package
Dual	TL062CD, ACD TL062CP, ACP	$T_A = 0^\circ$ to $+70^\circ\text{C}$	SO-8 Plastic DIP
	TL062VD TL062VP	$T_A = -40^\circ$ to $+85^\circ\text{C}$	SO-8 Plastic DIP
Quad	TL064CD, ACD TL064CN, ACN	$T_A = 0^\circ$ to $+70^\circ\text{C}$	SO-14 Plastic DIP
	TL064VD TL064VN	$T_A = -40^\circ$ to $+85^\circ\text{C}$	SO-14 Plastic DIP

TL062 TL064

LOW POWER JFET INPUT OPERATIONAL AMPLIFIERS

SEMICONDUCTOR TECHNICAL DATA

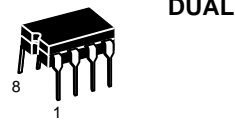

P SUFFIX
PLASTIC PACKAGE
CASE 626



D SUFFIX
PLASTIC PACKAGE
CASE 751
(SO-8)

PIN CONNECTIONS

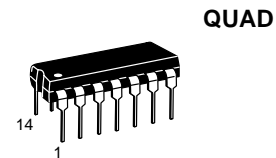
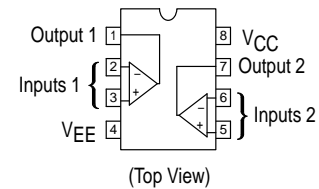

N SUFFIX
PLASTIC PACKAGE
CASE 646

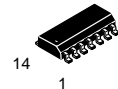

D SUFFIX
PLASTIC PACKAGE
CASE 751A
(SO-14)

PIN CONNECTIONS

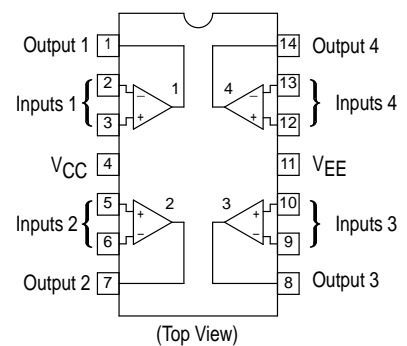

TL062 TL064

MAXIMUM RATINGS

Rating	Symbol	Value	Unit
Supply Voltage (from V_{CC} to V_{EE})	V_S	+36	V
Input Differential Voltage Range (Note 1)	V_{IDR}	± 30	V
Input Voltage Range (Notes 1 and 2)	V_{IR}	± 15	V
Output Short Circuit Duration (Note 3)	t_{SC}	Indefinite	sec
Operating Junction Temperature	T_J	+150	$^{\circ}\text{C}$
Storage Temperature Range	T_{stg}	-60 to +150	$^{\circ}\text{C}$

- NOTES:** 1. Differential voltages are at the noninverting input terminal with respect to the inverting input terminal.
 2. The magnitude of the input voltage must never exceed the magnitude of the supply or 15 V, whichever is less.
 3. Power dissipation must be considered to ensure maximum junction temperature (T_J) is not exceeded. (See Figure 1.)

ELECTRICAL CHARACTERISTICS ($V_{CC} = +15\text{ V}$, $V_{EE} = -15\text{ V}$, $T_A = 0^{\circ}$ to $+70^{\circ}\text{C}$, unless otherwise noted.)

Characteristics	Symbol	TL062AC TL064AC			TL062C TL064C			Unit
		Min	Typ	Max	Min	Typ	Max	
Input Offset Voltage ($R_S = 50\ \Omega$, $V_O = 0\text{ V}$) $T_A = 25^{\circ}\text{C}$ $T_A = 0^{\circ}$ to $+70^{\circ}\text{C}$	V_{IO}	— —	3.0 —	6.0 7.5	— —	3.0 —	15 20	mV
Average Temperature Coefficient for Offset Voltage ($R_S = 50\ \Omega$, $V_O = 0\text{ V}$)	$\Delta V_{IO}/\Delta T$	—	10	—	—	10	—	$\mu\text{V}/^{\circ}\text{C}$
Input Offset Current ($V_{CM} = 0\text{ V}$, $V_O = 0\text{ V}$) $T_A = 25^{\circ}\text{C}$ $T_A = 0^{\circ}$ to $+70^{\circ}\text{C}$	I_{IO}	— —	0.5 —	100 2.0	— —	0.5 —	200 2.0	pA nA
Input Bias Current ($V_{CM} = 0\text{ V}$, $V_O = 0\text{ V}$) $T_A = 25^{\circ}\text{C}$ $T_A = 0^{\circ}$ to $+70^{\circ}\text{C}$	I_{IB}	— —	3.0 —	200 2.0	— —	3.0 —	200 10	pA nA
Input Common Mode Voltage Range $T_A = 25^{\circ}\text{C}$	V_{ICR}	— -11.5	+14.5 -12.0	+11.5 —	— -11	+14.5 -12.0	+11 —	V
Large Signal Voltage Gain ($R_L = 10\text{ k}\Omega$, $V_O = \pm 10\text{ V}$) $T_A = 25^{\circ}\text{C}$ $T_A = 0^{\circ}$ to $+70^{\circ}\text{C}$	A_{VOL}	4.0 4.0	58 —	— —	3.0 3.0	58 —	— —	V/mV
Output Voltage Swing ($R_L = 10\text{ k}\Omega$, $V_{ID} = 1.0\text{ V}$) $T_A = 25^{\circ}\text{C}$	V_{O+} V_{O-}	+10 —	+14 -14	— -10	+10 —	+14 -14	— -10	V
$T_A = 0^{\circ}$ to $+70^{\circ}\text{C}$	V_{O+} V_{O-}	+10 —	— —	— -10	+10 —	— —	— -10	
Common Mode Rejection ($R_S = 50\ \Omega$, $V_{CM} = V_{ICR}\text{ min}$, $V_O = 0\text{ V}$, $T_A = 25^{\circ}\text{C}$)	CMR	80	84	—	70	84	—	dB
Power Supply Rejection ($R_S = 50\ \Omega$, $V_{CM} = 0\text{ V}$, $V_O = 0$, $T_A = 25^{\circ}\text{C}$)	PSR	80	86	—	70	86	—	dB
Power Supply Current (each amplifier) (No Load, $V_O = 0\text{ V}$, $T_A = 25^{\circ}\text{C}$)	I_D	—	200	250	—	200	250	μA
Total Power Dissipation (each amplifier) (No Load, $V_O = 0\text{ V}$, $T_A = 25^{\circ}\text{C}$)	P_D	—	6.0	7.5	—	6.0	7.5	mW

TL062 TL064

DC ELECTRICAL CHARACTERISTICS ($V_{CC} = +15\text{ V}$, $V_{EE} = -15\text{ V}$, $T_A = T_{low}$ to T_{high} [Note 4], unless otherwise noted.)

Characteristics	Symbol	TL062V			TL064V			Unit
		Min	Typ	Max	Min	Typ	Max	
Input Offset Voltage ($R_S = 50\ \Omega$, $V_O = 0\text{ V}$) $T_A = 25^\circ\text{C}$ $T_A = T_{low}$ to T_{high}	V_{IO}	— —	3.0 —	6.0 9.0	— —	3.0 —	9.0 15	mV
Average Temperature Coefficient for Offset Voltage ($R_S = 50\ \Omega$, $V_O = 0\text{ V}$)	$\Delta V_{IO}/\Delta T$	—	10	—	—	10	—	$\mu\text{V}/^\circ\text{C}$
Input Offset Current ($V_{CM} = 0\text{ V}$, $V_O = 0\text{ V}$) $T_A = 25^\circ\text{C}$ $T_A = T_{low}$ to T_{high}	I_{IO}	— —	5.0 —	100 20	— —	5.0 —	100 20	pA nA
Input Bias Current ($V_{CM} = 0\text{ V}$, $V_O = 0\text{ V}$) $T_A = 25^\circ\text{C}$ $T_A = T_{low}$ to T_{high}	I_{IB}	— —	30 —	200 50	— —	30 —	200 50	pA nA
Input Common Mode Voltage Range ($T_A = 25^\circ\text{C}$)	V_{ICR}	— -11.5	+14.5 -12.0	+11.5 —	— -11.5	+14.5 -12.0	+11.5 —	V
Large Signal Voltage Gain ($R_L = 10\text{ k}\Omega$, $V_O = \pm 10\text{ V}$) $T_A = 25^\circ\text{C}$ $T_A = T_{low}$ to T_{high}	A_{VOL}	4.0 4.0	58 —	— —	4.0 4.0	58 —	— —	V/mV
Output Voltage Swing ($R_L = 10\text{ k}\Omega$, $V_{ID} = 1.0\text{ V}$) $T_A = 25^\circ\text{C}$ $T_A = T_{low}$ to T_{high}	V_{O+} V_{O-} V_{O+} V_{O-}	+10 — +10 —	+14 -14 — —	— -10 — -10	+10 — +10 —	+14 -14 — —	— -10 — -10	V
Common Mode Rejection ($R_S = 50\ \Omega$, $V_{CM} = V_{ICR}\text{ min}$, $V_O = 0$, $T_A = 25^\circ\text{C}$)	CMR	80	84	—	80	84	—	dB
Power Supply Rejection ($R_S = 50\ \Omega$, $V_{CM} = 0\text{ V}$, $V_O = 0$, $T_A = 25^\circ\text{C}$)	PSR	80	86	—	80	86	—	dB
Power Supply Current (each amplifier) (No Load, $V_O = 0\text{ V}$, $T_A = 25^\circ\text{C}$)	I_D	—	200	250	—	200	250	μA
Total Power Dissipation (each amplifier) (No Load, $V_O = 0\text{ V}$, $T_A = 25^\circ\text{C}$)	P_D	—	6.0	7.5	—	6.0	7.5	mW

NOTE: 4. $T_{low} = -40^\circ\text{C}$ $T_{high} = +85^\circ\text{C}$ for TL062,4V

AC ELECTRICAL CHARACTERISTICS ($V_{CC} = +15\text{ V}$, $V_{EE} = -15\text{ V}$, $T_A = +25^\circ\text{C}$, unless otherwise noted.)

Characteristics	Symbol	Min	Typ	Max	Unit
Slew Rate ($V_{in} = -10\text{ V}$ to $+10\text{ V}$, $R_L = 10\text{ k}\Omega$, $C_L = 100\text{ pF}$, $A_V = +1.0$)	SR	2.0	6.0	—	V/ μs
Rise Time ($V_{in} = 20\text{ mV}$, $R_L = 10\text{ k}\Omega$, $C_L = 100\text{ pF}$, $A_V = +1.0$)	t_r	—	0.1	—	μs
Overshoot ($V_{in} = 20\text{ mV}$, $R_L = 10\text{ k}\Omega$, $C_L = 100\text{ pF}$, $A_V = +1.0$)	OS	—	10	—	%
Settling Time ($V_{CC} = +15\text{ V}$, $V_{EE} = -15\text{ V}$, $A_V = -1.0$, $R_L = 10\text{ k}\Omega$, $V_O = 0\text{ V}$ to $+10\text{ V}$ step)	t_S	— —	1.6 2.2	— —	μs
To within 10 mV					
To within 1.0 mV					
Gain Bandwidth Product ($f = 200\text{ kHz}$)	GBW	—	2.0	—	MHz
Equivalent Input Noise ($R_S = 100\ \Omega$, $f = 1.0\text{ kHz}$)	e_n	—	47	—	nV/ $\sqrt{\text{Hz}}$
Input Resistance	R_i	—	10^{12}	—	Ω
Channel Separation ($f = 10\text{ kHz}$)	CS	—	120	—	dB

Figure 1. Maximum Power Dissipation versus Temperature for Package Variations

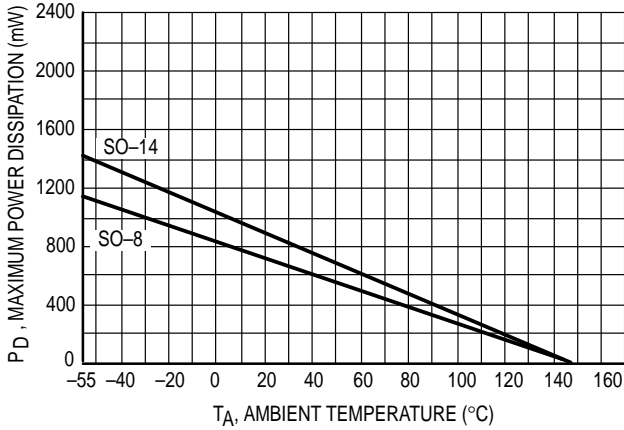

Figure 2. Output Voltage Swing versus Supply Voltage

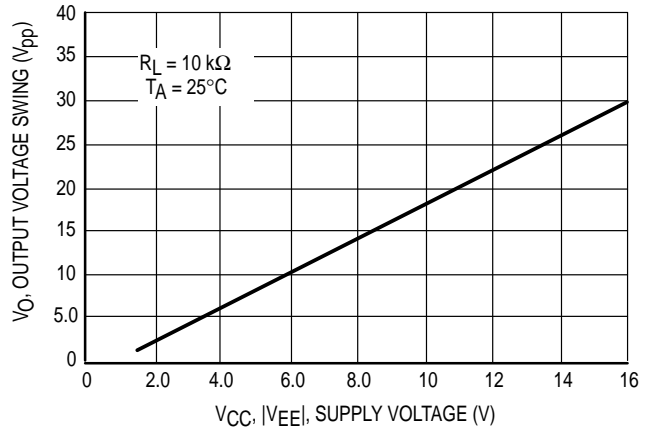

Figure 3. Output Voltage Swing versus Temperature

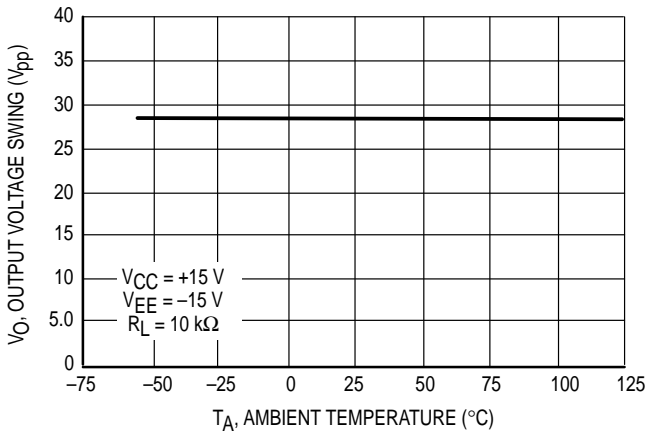

Figure 4. Output Voltage Swing versus Load Resistance

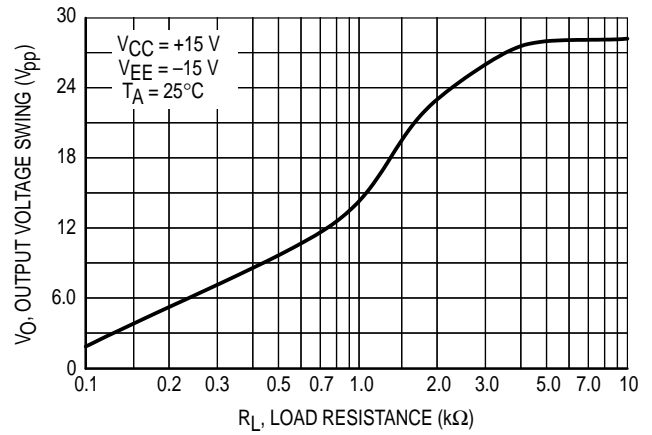

Figure 5. Output Voltage Swing versus Frequency

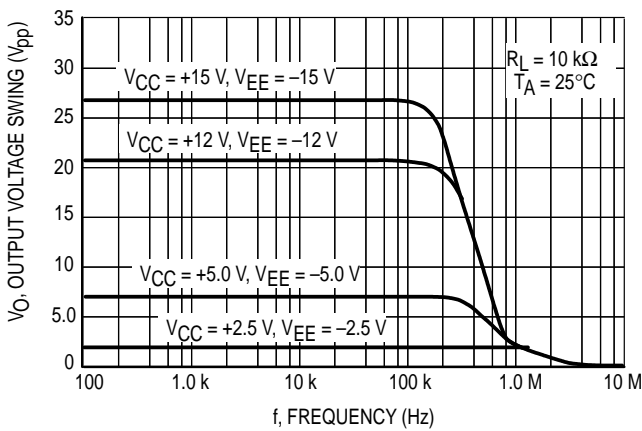

Figure 6. Large Signal Voltage Gain versus Temperature

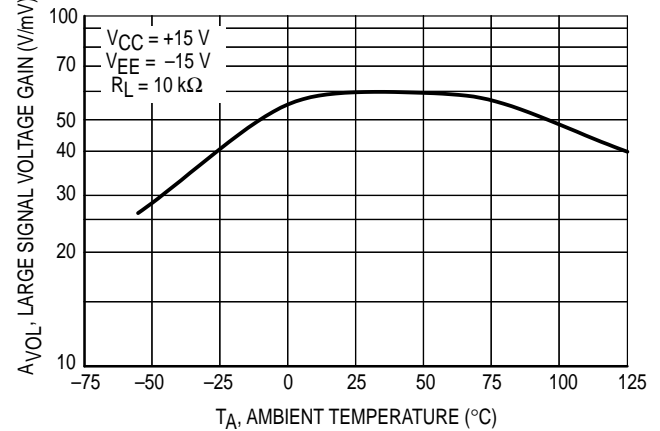

Figure 7. Open Loop Voltage Gain and Phase versus Frequency

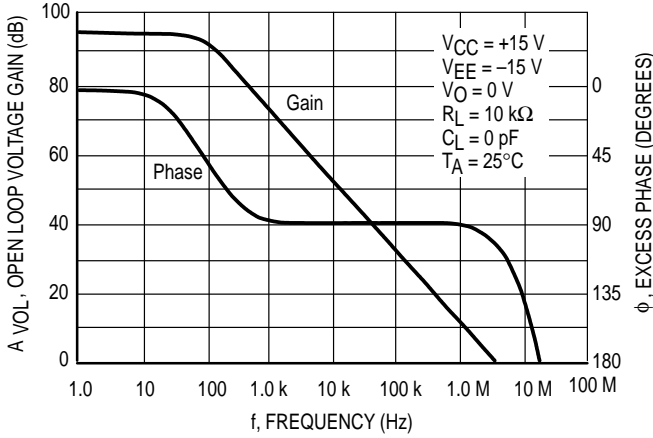

Figure 8. Supply Current per Amplifier versus Supply Voltage

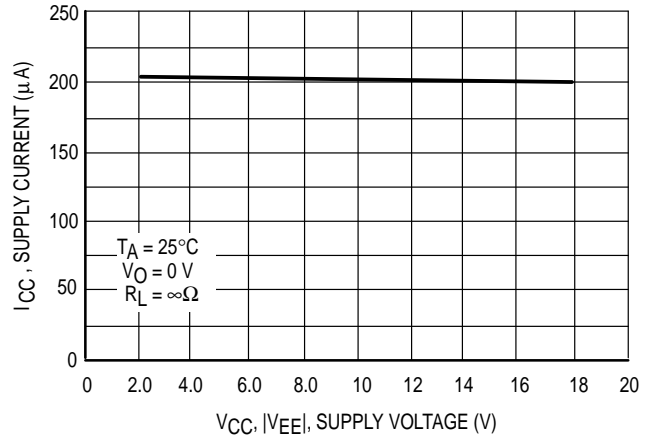

Figure 9. Supply Current per Amplifier versus Temperature

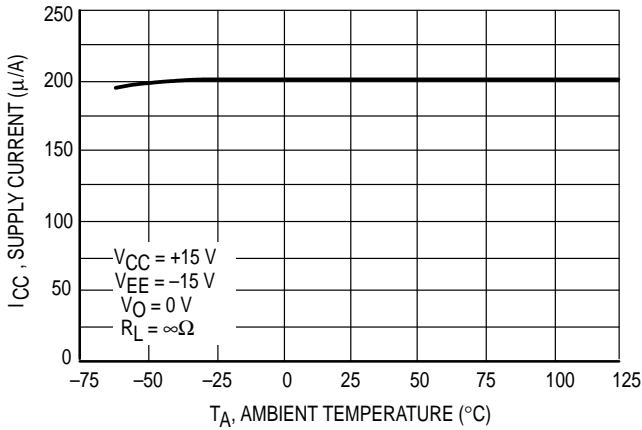

Figure 10. Total Power Dissipation versus Temperature

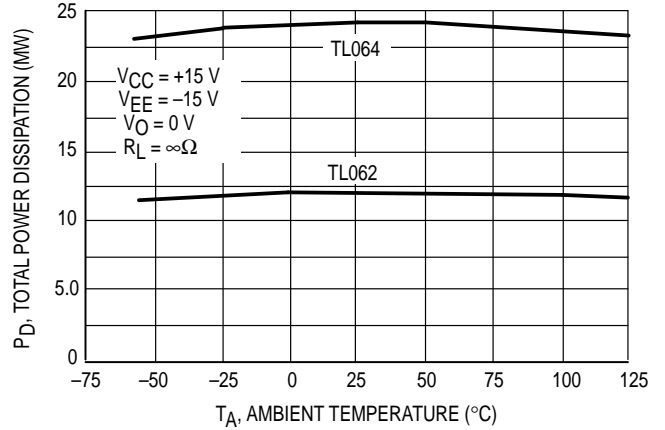

Figure 11. Common Mode Rejection versus Temperature

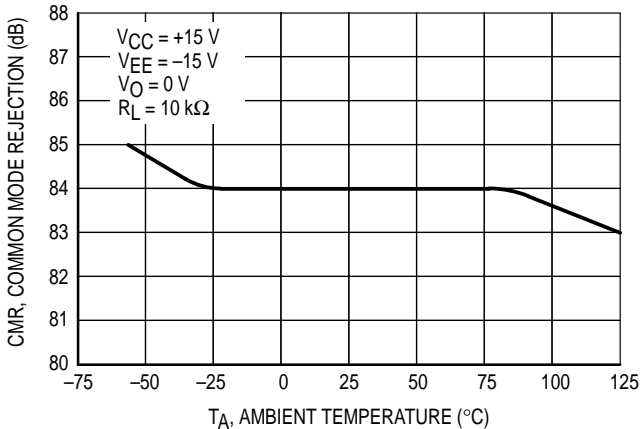

Figure 12. Common Mode Rejection versus Frequency

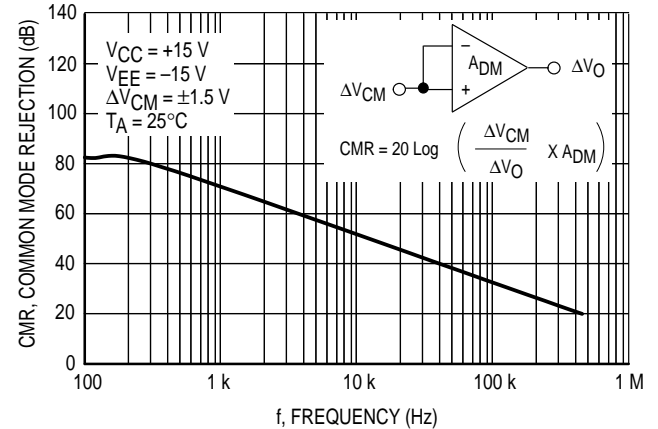

Figure 13. Power Supply Rejection versus Frequency

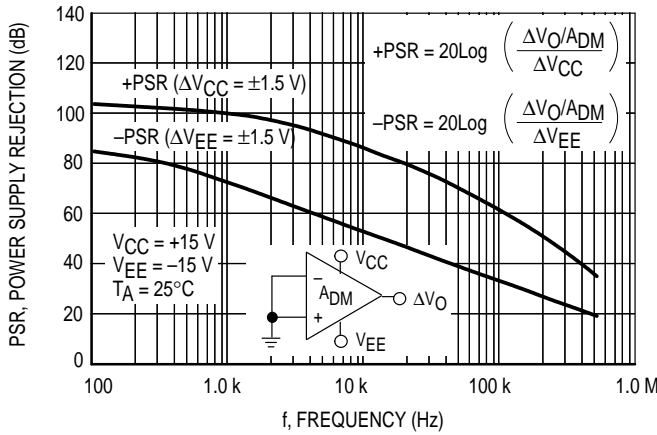

Figure 14. Normalized Gain Bandwidth Product, Slew Rate and Phase Margin versus Temperature

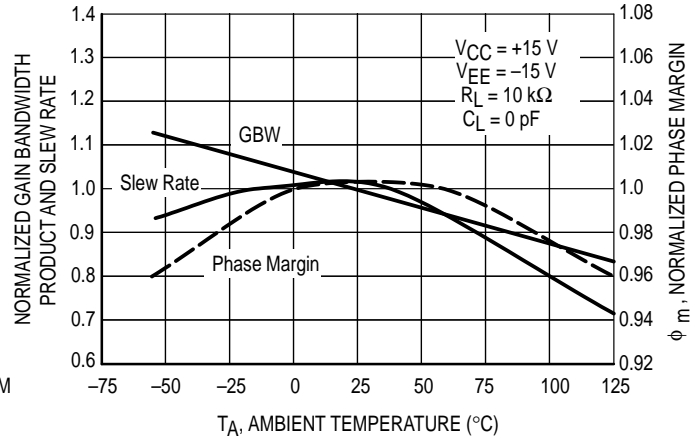

Figure 15. Input Bias Current versus Temperature

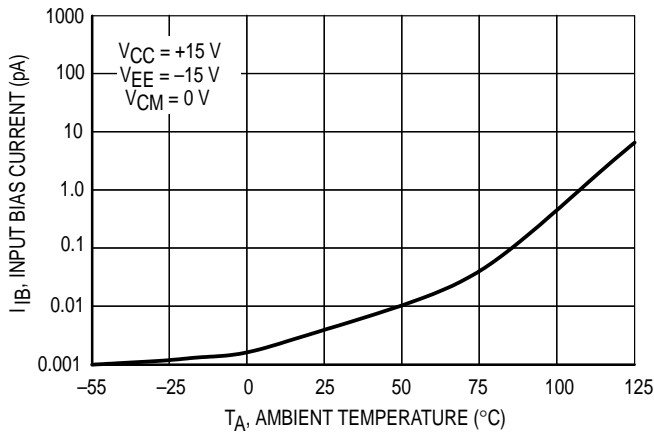

Figure 16. Input Noise Voltage versus Frequency

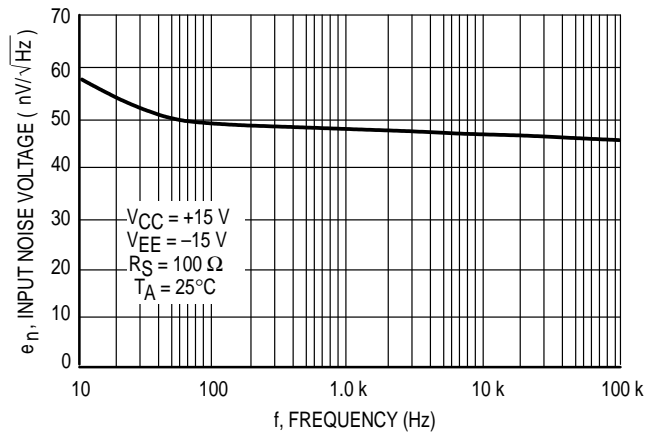

Figure 17. Small Signal Response

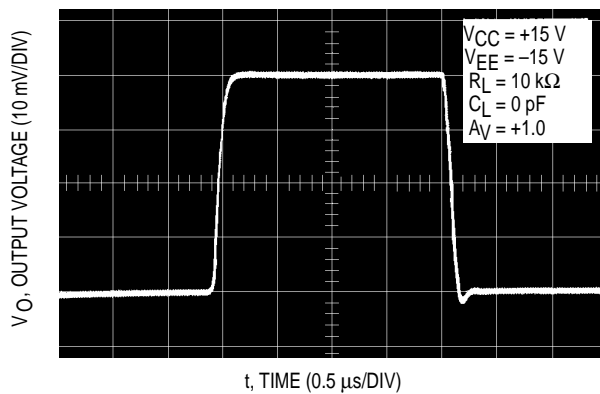
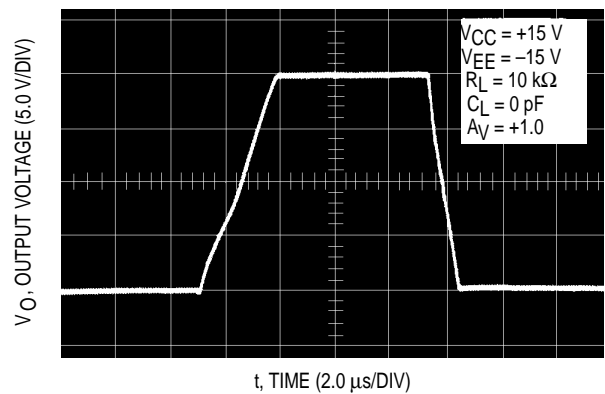

Figure 18. Large Signal Response



TL062 TL064

Figure 19. AC Amplifier

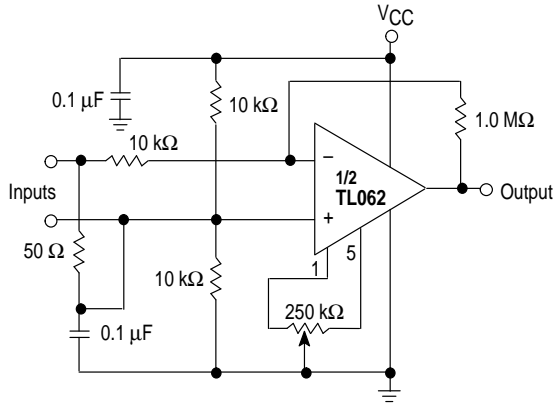

Figure 20. High-Q Notch Filter

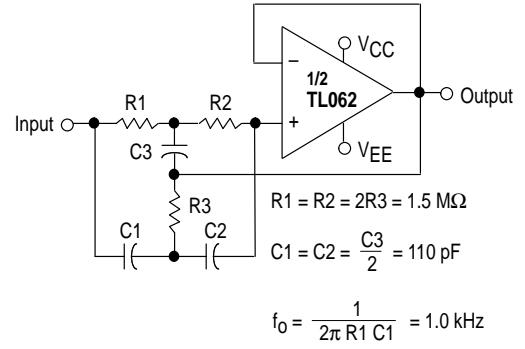

Figure 21. Instrumentation Amplifier

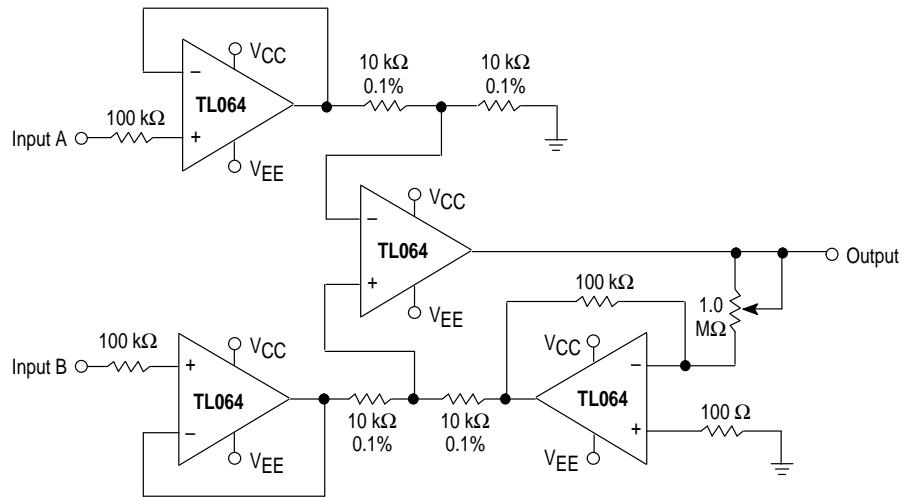

Figure 22. 0.5 Hz Square-Wave Oscillator

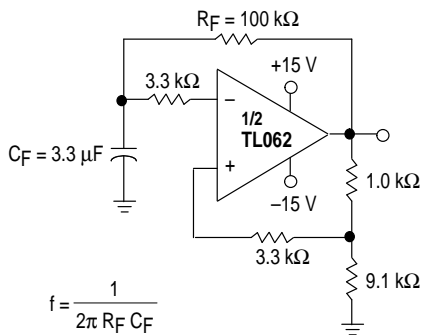
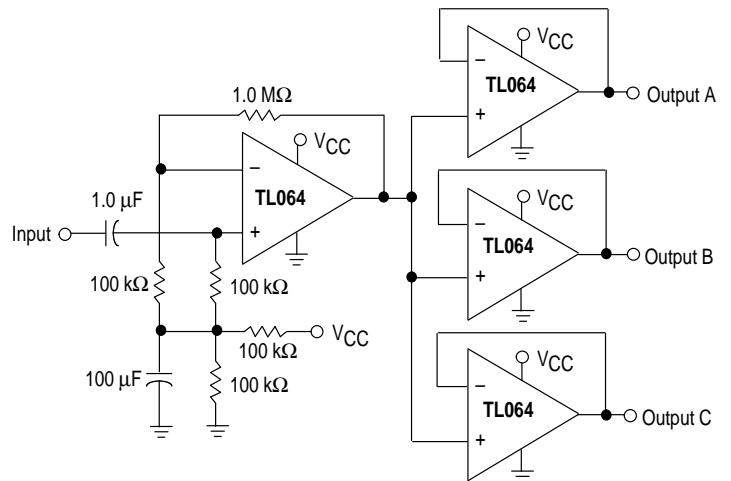

Figure 23. Audio Distribution Amplifier



TL062 TL064

OUTLINE DIMENSIONS

P SUFFIX PLASTIC PACKAGE CASE 626-05 ISSUE K

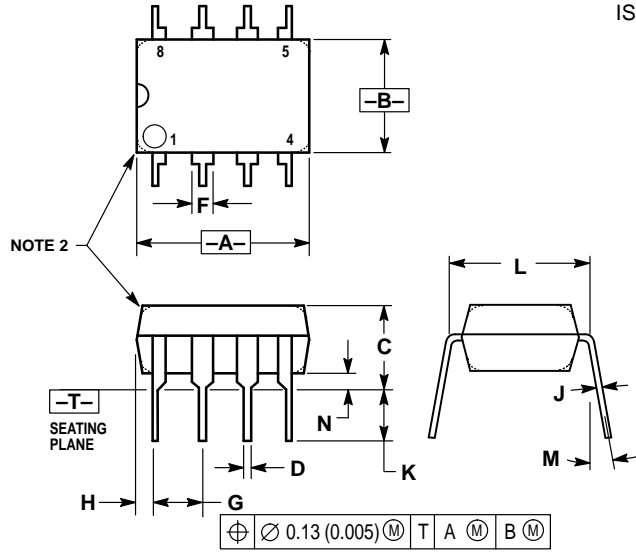

NOTES:

1. DIMENSION L TO CENTER OF LEAD WHEN FORMED PARALLEL.
2. PACKAGE CONTOUR OPTIONAL (ROUND OR SQUARE CORNERS).
3. DIMENSIONING AND TOLERANCING PER ANSI Y14.5M, 1982.

DIM	MILLIMETERS		INCHES	
	MIN	MAX	MIN	MAX
A	9.40	10.16	0.370	0.400
B	6.10	6.60	0.240	0.260
C	3.94	4.45	0.155	0.175
D	0.38	0.51	0.015	0.020
F	1.02	1.78	0.040	0.070
G	2.54 BSC		0.100 BSC	
H	0.76	1.27	0.030	0.050
J	0.20	0.30	0.008	0.012
K	2.92	3.43	0.115	0.135
L	7.62 BSC		0.300 BSC	
M	—		10°	
N	0.76	1.01	0.030	0.040

D SUFFIX PLASTIC PACKAGE CASE 751-05 (SO-8) ISSUE R

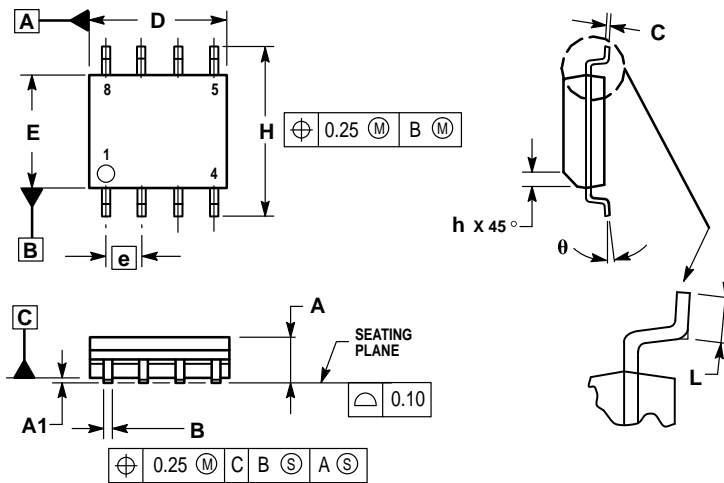

NOTES:

1. DIMENSIONING AND TOLERANCING PER ASME Y14.5M, 1994.
2. DIMENSIONS ARE IN MILLIMETERS.
3. DIMENSION D AND E DO NOT INCLUDE MOLD PROTRUSION.
4. MAXIMUM MOLD PROTRUSION 0.15 PER SIDE.
5. DIMENSION B DOES NOT INCLUDE MOLD PROTRUSION. ALLOWABLE DAMBAR PROTRUSION SHALL BE 0.127 TOTAL IN EXCESS OF THE B DIMENSION AT MAXIMUM MATERIAL CONDITION.

DIM	MILLIMETERS	
	MIN	MAX
A	1.35	1.75
A1	0.10	0.25
B	0.35	0.49
C	0.18	0.25
D	4.80	5.00
E	3.80	4.00
e	1.27 BSC	
H	5.80	6.20
h	0.25	0.50
L	0.40	1.25
θ	0° 7°	

TL062 TL064

OUTLINE DIMENSIONS

N SUFFIX PLASTIC PACKAGE CASE 646-06 ISSUE L

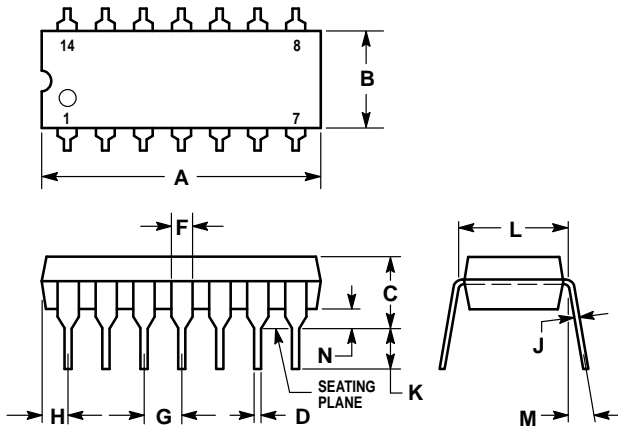

NOTES:

- LEADS WITHIN 0.13 (0.005) RADIUS OF TRUE POSITION AT SEATING PLANE AT MAXIMUM MATERIAL CONDITION.
- DIMENSION L TO CENTER OF LEADS WHEN FORMED PARALLEL.
- DIMENSION B DOES NOT INCLUDE MOLD FLASH.
- ROUNDED CORNERS OPTIONAL.

DIM	INCHES		MILLIMETERS	
	MIN	MAX	MIN	MAX
A	0.715	0.770	18.16	19.56
B	0.240	0.260	6.10	6.60
C	0.145	0.185	3.69	4.69
D	0.015	0.021	0.38	0.53
F	0.040	0.070	1.02	1.78
G	0.100 BSC		2.54 BSC	
H	0.052	0.095	1.32	2.41
J	0.008	0.015	0.20	0.38
K	0.115	0.135	2.92	3.43
L	0.300 BSC		7.62 BSC	
M	0°	10°	0°	10°
N	0.015	0.039	0.39	1.01

D SUFFIX PLASTIC PACKAGE CASE 751A-03 (SO-14) ISSUE F

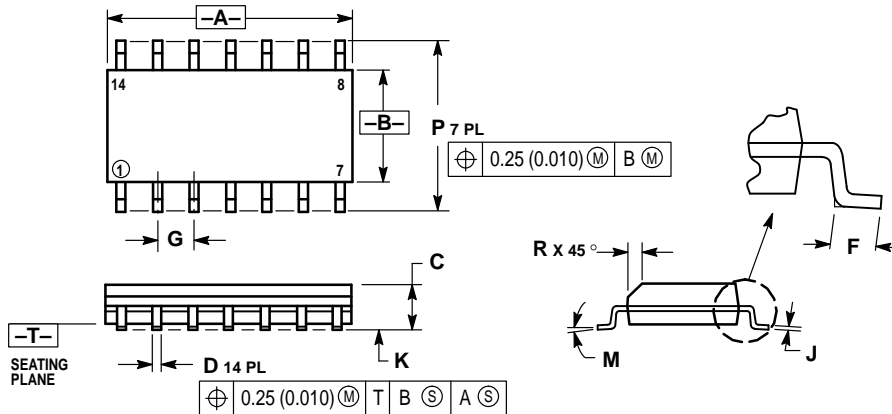

NOTES:

- DIMENSIONING AND TOLERANCING PER ANSI Y14.5M, 1982.
- CONTROLLING DIMENSION: MILLIMETER.
- DIMENSIONS A AND B DO NOT INCLUDE MOLD PROTRUSION.
- MAXIMUM MOLD PROTRUSION 0.15 (0.006) PER SIDE.
- DIMENSION D DOES NOT INCLUDE DAMBAR PROTRUSION. ALLOWABLE DAMBAR PROTRUSION SHALL BE 0.127 (0.005) TOTAL IN EXCESS OF THE D DIMENSION AT MAXIMUM MATERIAL CONDITION.

DIM	MILLIMETERS		INCHES	
	MIN	MAX	MIN	MAX
A	8.55	8.75	0.337	0.344
B	3.80	4.00	0.150	0.157
C	1.35	1.75	0.054	0.068
D	0.35	0.49	0.014	0.019
F	0.40	1.25	0.016	0.049
G	1.27 BSC		0.050 BSC	
J	0.19	0.25	0.008	0.009
K	0.10	0.25	0.004	0.009
M	0°	7°	0°	7°
P	5.80	6.20	0.228	0.244
R	0.25	0.50	0.010	0.019