



TIP120, TIP121, TIP122 TIP125, TIP126, TIP127

Complementary power Darlington transistors

Features

- Low collector-emitter saturation voltage
- Complementary NPN - PNP transistors

Applications

- General purpose linear and switching

Description

The devices are manufactured in planar technology with “base island” layout and monolithic Darlington configuration. The resulting transistors show exceptional high gain performance coupled with very low saturation voltage.

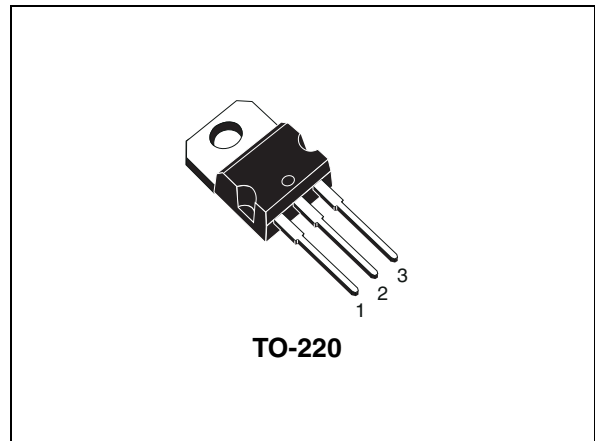

Figure 1. Internal schematic diagrams

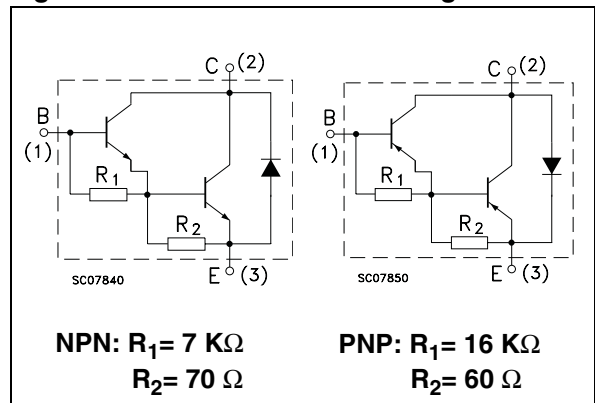

Table 1. Device summary

Order codes	Marking	Package	Packaging
TIP120	TIP120	TO-220	Tube
TIP121	TIP121		
TIP122	TIP122		
TIP125	TIP125		
TIP126	TIP126		
TIP127	TIP127		

Content

1	Electrical ratings	3
2	Electrical characteristics	4
	2.1 Electrical characteristics (curves)	5
3	Test circuits	7
4	Package mechanical data	8
5	Revision history	11

1 Electrical ratings

Table 2. Absolute maximum rating⁽¹⁾

Symbol	Parameter	Value				Unit
		NPN	TIP120	TIP121	TIP122	
		PNP	TIP125	TIP126	TIP127	
V_{CBO}	Collector-base voltage ($I_E = 0$)	60	80	100	V	
V_{CEO}	Collector-emitter voltage ($I_B = 0$)	60	80	100	V	
V_{EBO}	Emitter-base voltage ($I_C = 0$)	5			V	
I_C	Collector current	5			A	
I_{CM}	Collector peak current	8			A	
I_B	Base current	0.12			A	
P_{TOT}	Total dissipation at $T_C \leq 25\text{ °C}$ $T_{amb} \leq 25\text{ °C}$	65			W	
		2				
T_{stg}	Storage temperature	-65 to 150			°C	
T_J	Max. operating junction temperature	150				

1. For PNP types voltage and current values are negative.

Table 3. Thermal data

Symbol	Parameter	Value	Unit
$R_{thj-case}$	Thermal resistance junction-case max.	1.92	°C/W
$R_{thj-amb}$	Thermal resistance junction-ambient max.	62.5	

2 Electrical characteristics

($T_{\text{case}} = 25\text{ °C}$; unless otherwise specified)

Table 4. Electrical characteristics⁽¹⁾

Symbol	Parameter	Test conditions	Min.	Typ.	Max.	Unit
I_{CEO}	Collector cut-off current ($I_{\text{B}} = 0$)	for TIP120/125 $V_{\text{CE}} = 30\text{ V}$ for TIP121/126 $V_{\text{CE}} = 40\text{ V}$ for TIP122/127 $V_{\text{CE}} = 50\text{ V}$			0.5 0.5 0.5	mA mA mA
I_{CBO}	Collector cut-off current ($I_{\text{B}} = 0$)	for TIP120/125 $V_{\text{CE}} = 60\text{ V}$ for TIP121/126 $V_{\text{CE}} = 80\text{ V}$ for TIP122/127 $V_{\text{CE}} = 100\text{ V}$			0.2 0.2 0.2	mA mA mA
I_{EBO}	Emitter cut-off current ($I_{\text{C}} = 0$)	$V_{\text{EB}} = 5\text{ V}$			2	mA
$V_{\text{CEO(sus)}}^{(2)}$	Collector-emitter sustaining voltage ($I_{\text{B}} = 0$)	$I_{\text{C}} = 30\text{ mA}$ for TIP120/125 for TIP121/126 for TIP122/127	60 80 100			V V V
$V_{\text{CE(sat)}}^{(2)}$	Collector-emitter saturation voltage	$I_{\text{C}} = 3\text{ A}$ $I_{\text{B}} = 12\text{ mA}$ $I_{\text{C}} = 5\text{ A}$ $I_{\text{B}} = 20\text{ mA}$			2 4	V V
$V_{\text{BE(on)}}^{(2)}$	Base-emitter on voltage	$I_{\text{C}} = 3\text{ A}$ $V_{\text{CE}} = 3\text{ V}$			2.5	V
$h_{\text{FE}}^{(2)}$	DC current gain	$I_{\text{C}} = 0.5\text{ A}$ $V_{\text{CE}} = 3\text{ V}$ $I_{\text{C}} = 3\text{ A}$ $V_{\text{CE}} = 3\text{ V}$	1000 1000			

1. For PNP types voltage and current values are negative.

2. Pulsed duration = 300 μs , duty cycle $\leq 2\%$

2.1 Electrical characteristics (curves)

Figure 2. Safe operating area

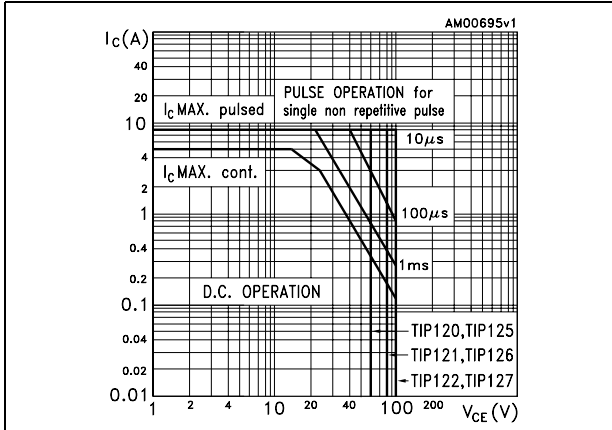

Figure 3. Derating curve

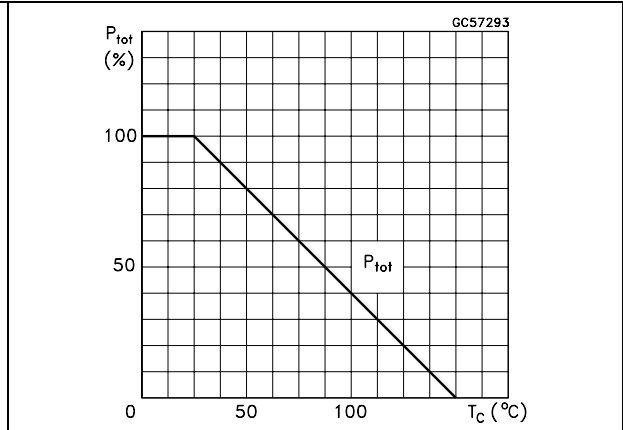

Figure 4. DC current gain for NPN type

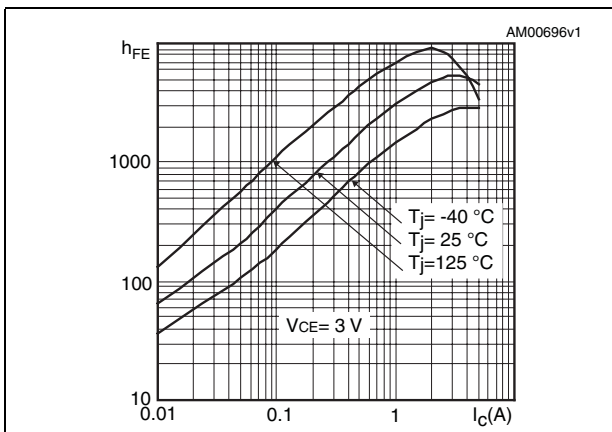

Figure 5. DC current gain for PNP type

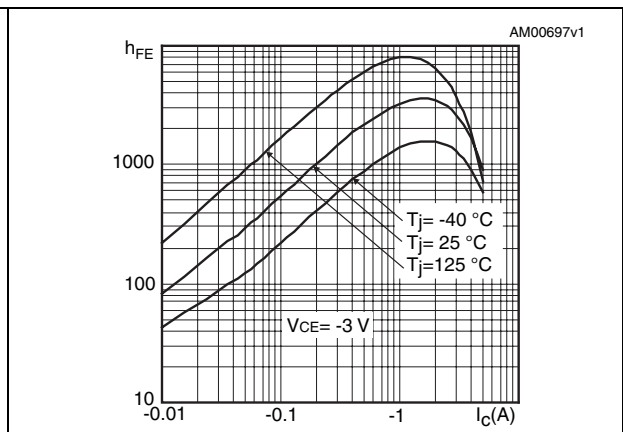

Figure 6. Collector-emitter saturation voltage for NPN type

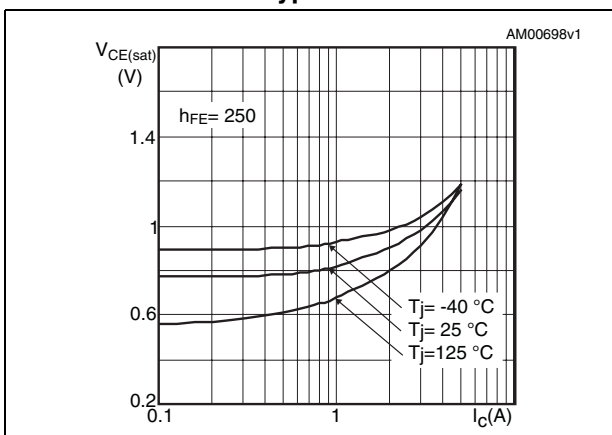

Figure 7. Collector-emitter saturation voltage for PNP type

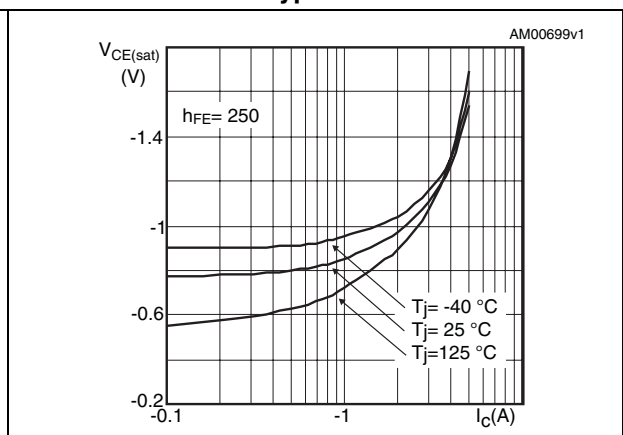

Figure 8. Base-emitter saturation voltage for NPN type

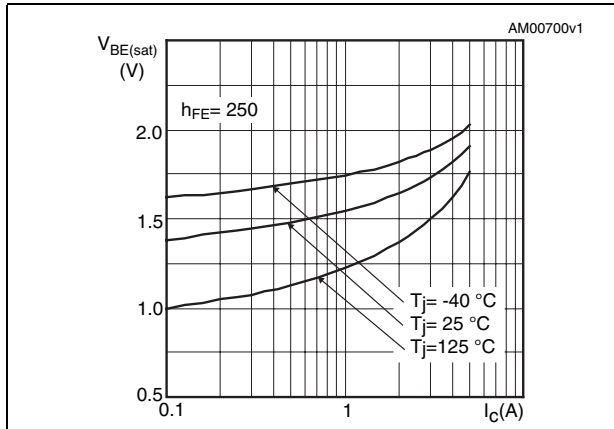

Figure 9. Base-emitter saturation voltage for PNP type

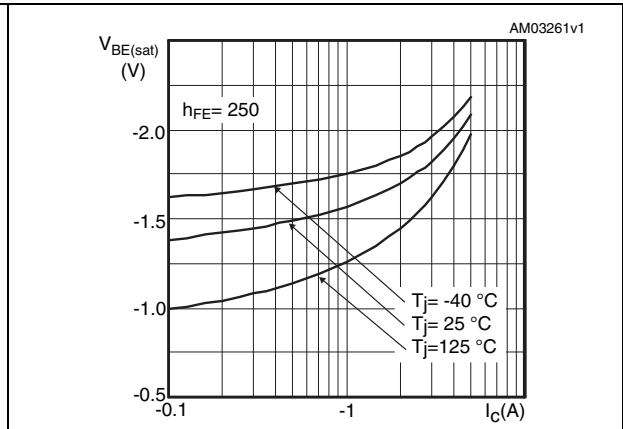

Figure 10. Base-emitter on voltage for NPN type

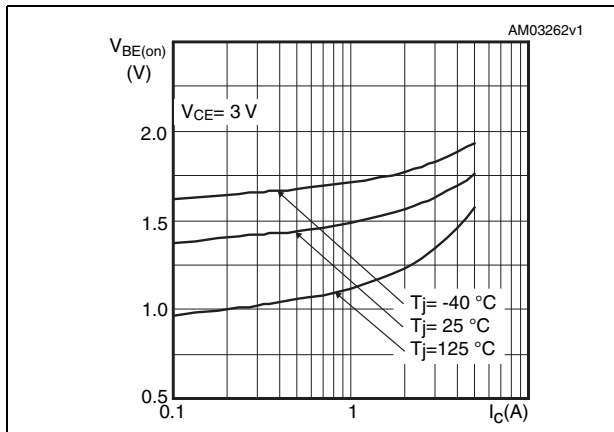

Figure 11. Base-emitter on voltage for PNP type

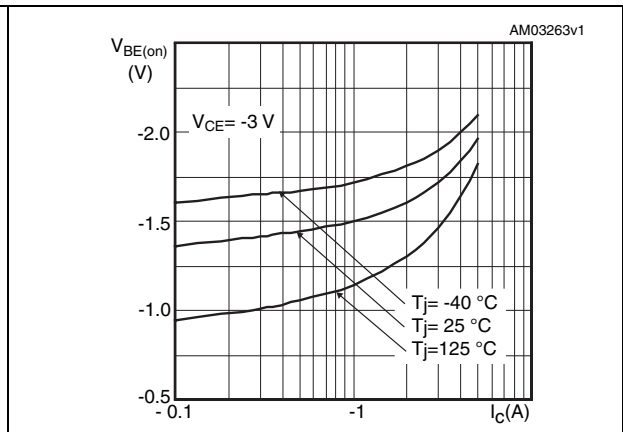

Figure 12. Switching time on resistive load for NPN type (on)

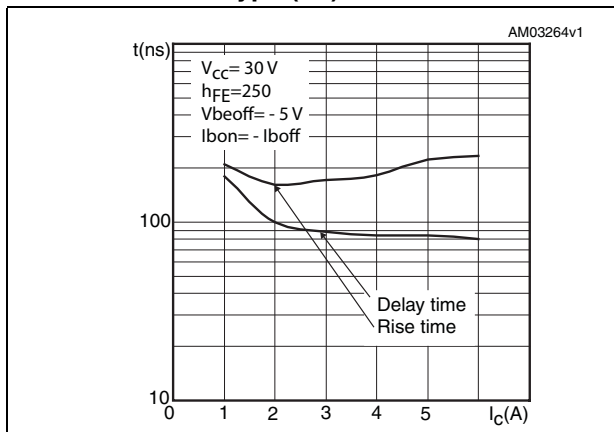

Figure 13. Switching time on resistive load for PNP type (on)

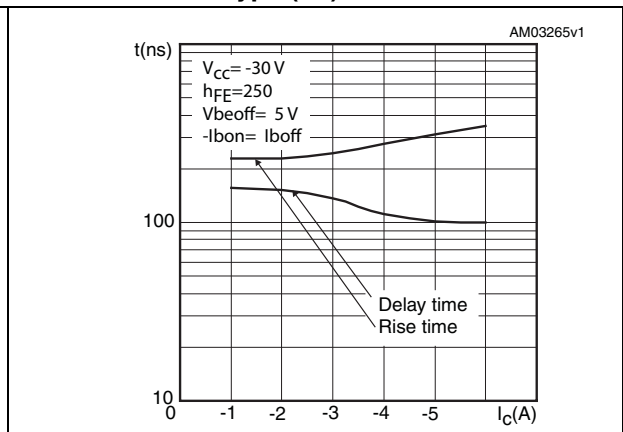

Figure 14. Switching time on resistive load for NPN type (off)

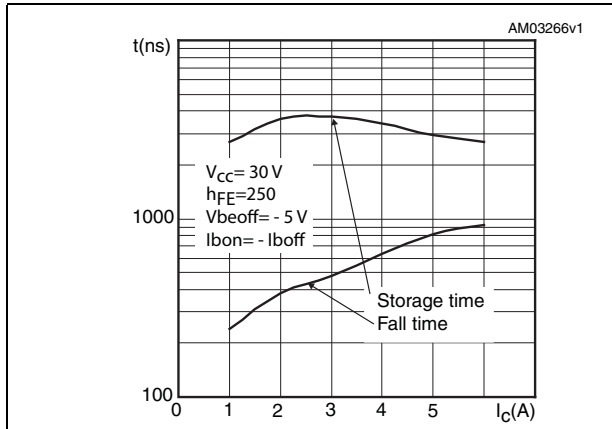

Figure 15. Switching time on resistive load for PNP type (off)

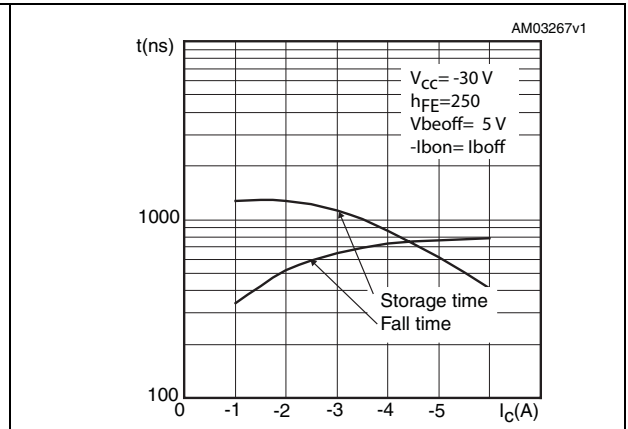

Figure 16. Capacitances for NPN type

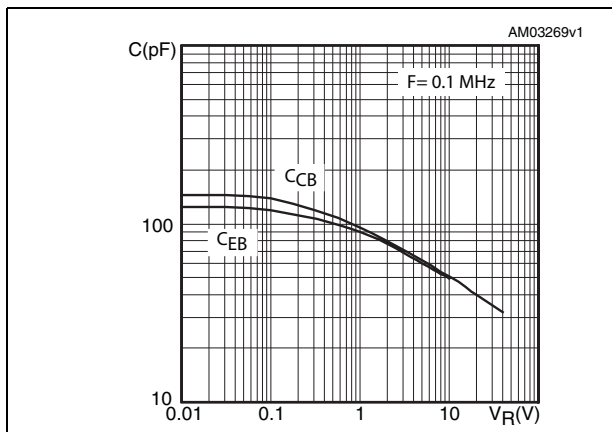
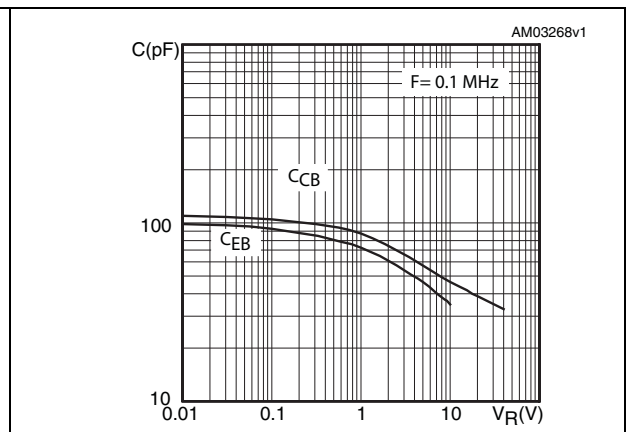

Figure 17. Capacitances for PNP type



3 Test circuits

Figure 18. Resistive load switching for NPN type

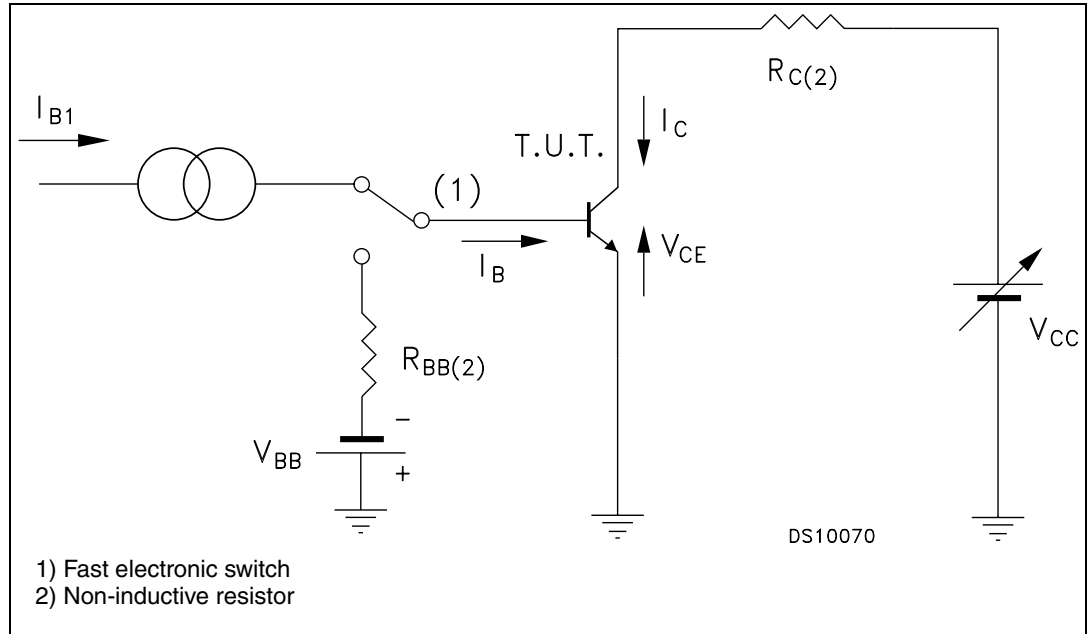
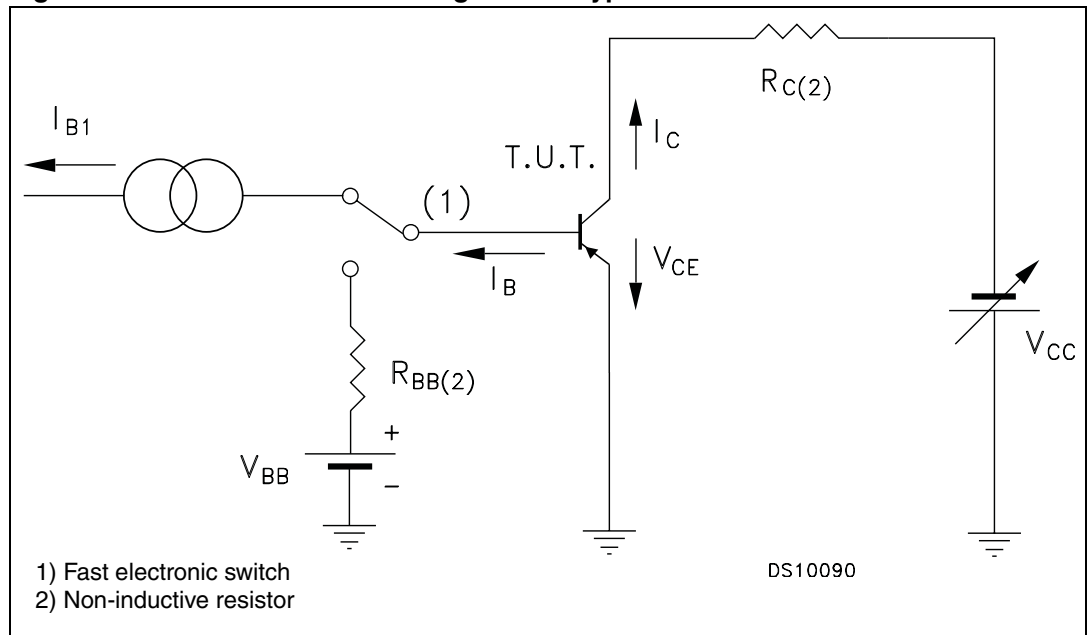

Figure 19. Resistive load switching for PNP type



4 Package mechanical data

In order to meet environmental requirements, ST offers these devices in ECOPACK® packages. These packages have a lead-free second level interconnect . The category of second level interconnect is marked on the package and on the inner box label, in compliance with JEDEC Standard JESD97. The maximum ratings related to soldering conditions are also marked on the inner box label. ECOPACK is an ST trademark. ECOPACK specifications are available at: www.st.com

TO-220 mechanical data

Dim	mm			inch		
	Min	Typ	Max	Min	Typ	Max
A	4.40		4.60	0.173		0.181
b	0.61		0.88	0.024		0.034
b1	1.14		1.70	0.044		0.066
c	0.48		0.70	0.019		0.027
D	15.25		15.75	0.6		0.62
D1		1.27			0.050	
E	10		10.40	0.393		0.409
e	2.40		2.70	0.094		0.106
e1	4.95		5.15	0.194		0.202
F	1.23		1.32	0.048		0.051
H1	6.20		6.60	0.244		0.256
J1	2.40		2.72	0.094		0.107
L	13		14	0.511		0.551
L1	3.50		3.93	0.137		0.154
L20		16.40			0.645	
L30		28.90			1.137	
∅P	3.75		3.85	0.147		0.151
Q	2.65		2.95	0.104		0.116

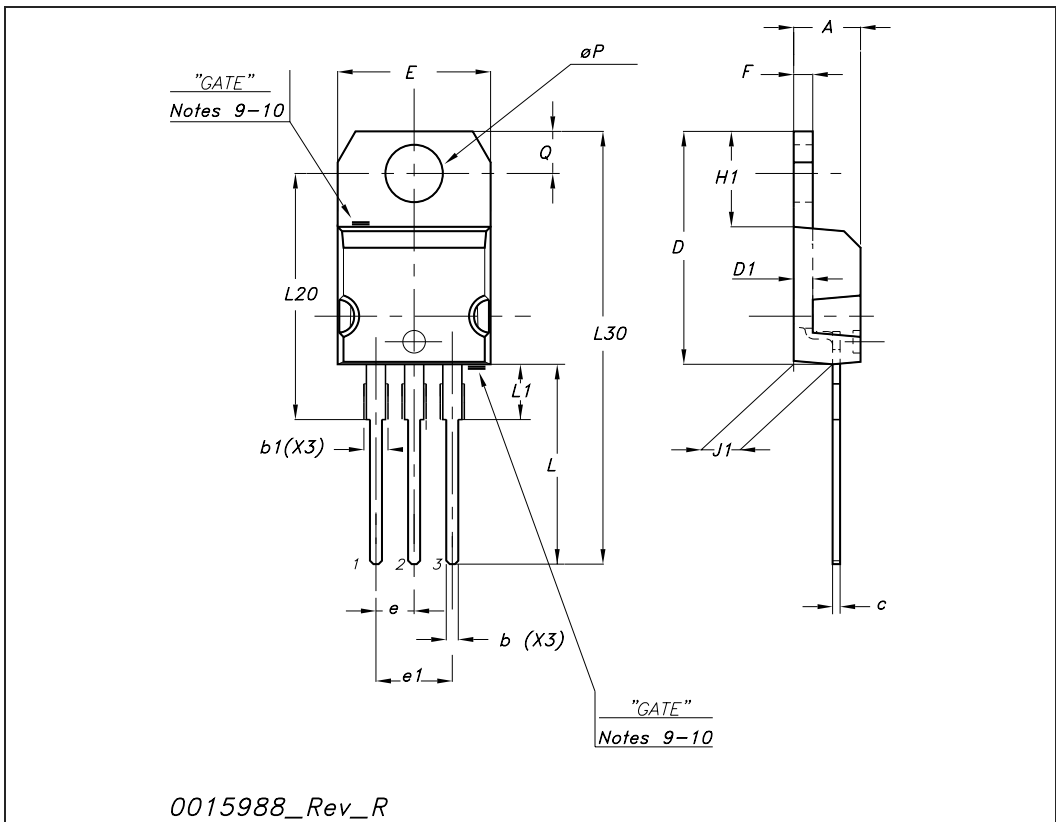

TO-220 type E mechanical data

DIM.	mm.		
	MIN.	TYP	MAX.
A	4.47		4.67
b	0.70		0.91
b1	1.17		1.37
c	0.31		0.53
D	14.60		15.70
E	9.96		10.36
e		2.54	
e1	4.98	5.08	5.18
F	1.17		1.37
H1	6.10		6.80
J1	2.52		2.82
L	12.70		13.80
L1	3.20		3.96
L20	15.21		16.77
øP	3.73		3.94
Q	2.59		2.89

