



VERTICAL DEFLECTION BOOSTER

FEATURES SUMMARY

- POWER AMPLIFIER
- FLYBACK GENERATOR
- THERMAL PROTECTION
- OUTPUT CURRENT UP TO 3.0A_{PP}
- FLYBACK VOLTAGE UP TO 70V (on Pin 5)
- SUITABLE FOR DC COUPLING APPLICATION

DESCRIPTION

Designed for monitors and high performance TVs, the TDA8177 vertical deflection booster delivers flyback voltages up to 70V.

The TDA8177 operates with supplies up to 35V and provides up to 3A_{PP} output current to drive the yoke.

The TDA8177 is offered in HEPTAWATT package.

Figure 1. Package

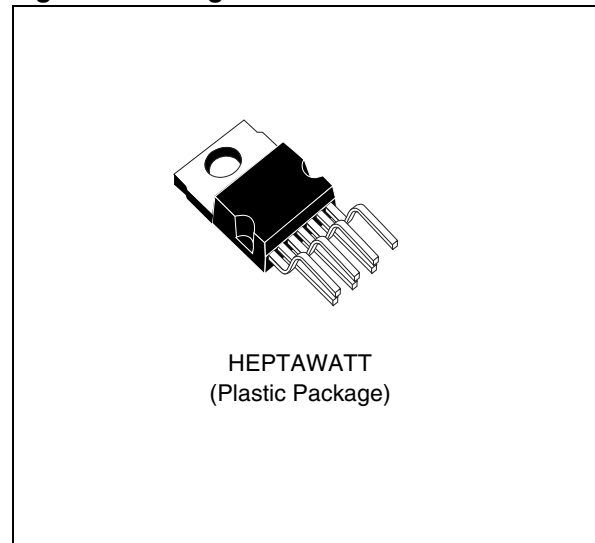

Figure 2. Pin Connections

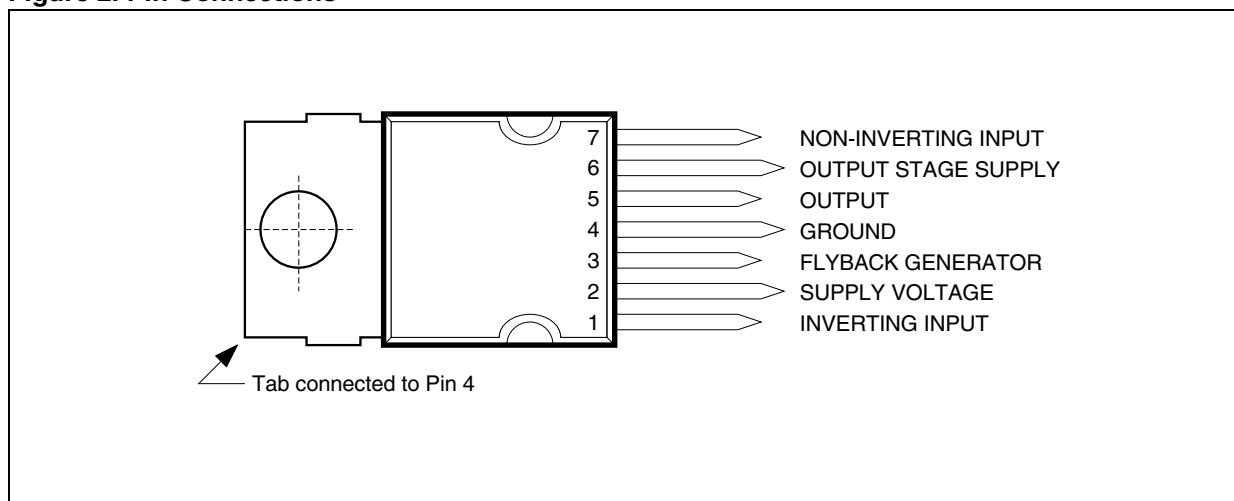

Figure 3. Block Diagram

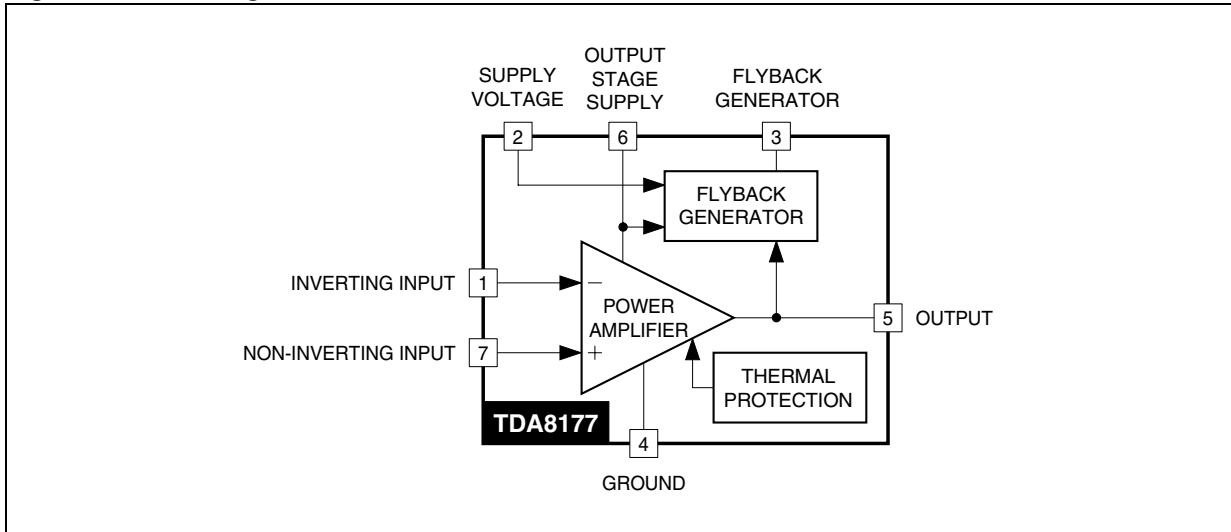

Table 1. Absolute Maximum Ratings

Symbol	Parameter	Value	Unit
V_S	Supply Voltage (Pin 2) (see note 1)	40	V
V_6	Flyback Peak Voltage (Pin 6) (see note 1)	75	V
V_1, V_7	Amplifier Input Voltage (Pins 1-7) (see note 1)	- 0.3, + V_S	V
I_o	Maximum Output Peak Current (see notes 2 and 3)	2.5	A
I_3	Maximum Sink Current (first part of flyback) ($t < 1\text{ms}$)	2.5	A
I_3	Maximum Source Current ($t < 1\text{ms}$)	2.5	A
V_{ESD}	Electrostatic Handling for all pins (see note 4)	2000	V
T_{OPER}	Operating Ambient Temperature	- 20, + 75	°C
T_{STG}	Storage Temperature	- 40, + 150	°C
T_j	Junction Temperature	+ 150	°C

- Note: 1. Versus Pin 4.
 2. The output current can reach 4A peak for $t \leq 10\mu\text{s}$ (up to 120Hz).
 3. Provided SOAR is respected (see Figures 6 and 7).
 4. Equivalent to discharging a 100pF capacitor through a 1.5kΩ series resistor.

Table 2. Thermal Data

Symbol	Parameter	Value	Unit
$R_{th(j-c)}$	Junction-case Thermal Resistance Max	3	°C/W
T_t	Temperature for Thermal Shutdown	150	°C
T_{jr}	Recommended Max. Junction Temperature	120	°C

Table 3. ELECTRICAL CHARACTERISTICS
 ($V_S = 35V$, $T_A = 25^\circ C$, unless otherwise specified)

Symbol	Parameter	Test Conditions	Min.	Typ.	Max.	Unit
V_S	Operating Supply Voltage Range		10		35	V
I_2	Pin 2 Quiescent Current	$I_3 = 0, I_5 = 0$		9	20	mA
I_6	Pin 6 Quiescent Current	$I_3 = 0, I_5 = 0, V_6 = 35V$	8	15	30	mA
I_O	Max. Peak Output Current				1.5	A
I_1	Amplifier Bias Current	$V_1 = 22V, V_7 = 23V$		-0.15	-1	μA
I_7	Amplifier Bias Current	$V_1 = 23V, V_7 = 22V$		-0.15	-1	μA
V_{IO}	Offset Voltage				7	mV
$\Delta V_{IO} / dt$	Offset Drift versus Temperature			-10		$\mu V/^\circ C$
GV	Voltage Gain		80			dB
V_{5L}	Output Saturation Voltage to GND (Pin 4)	$I_5 = 1.5A$		1	1.7	V
V_{5H}	Output Saturation Voltage to Supply (Pin 6)	$I_5 = -1.5A$		1.8	2.3	V
V_{D5-6}	Diode Forward Voltage between Pins 5-6	$I_5 = 1.5A$		1.8	2.3	V
V_{D3-2}	Diode Forward Voltage between Pins 3-2	$I_3 = 1.5A$		1.6	2.2	V
V_{3SL}	Saturation Voltage on Pin 3	$I_3 = 20mA$		0.4	1	V
V_{3SH}	Saturation Voltage to Pin 2 (2nd part of flyback)	$I_3 = 1.5A$		2.1	2.8	V

APPLICATION CIRCUITS

Figure 4. AC Coupling

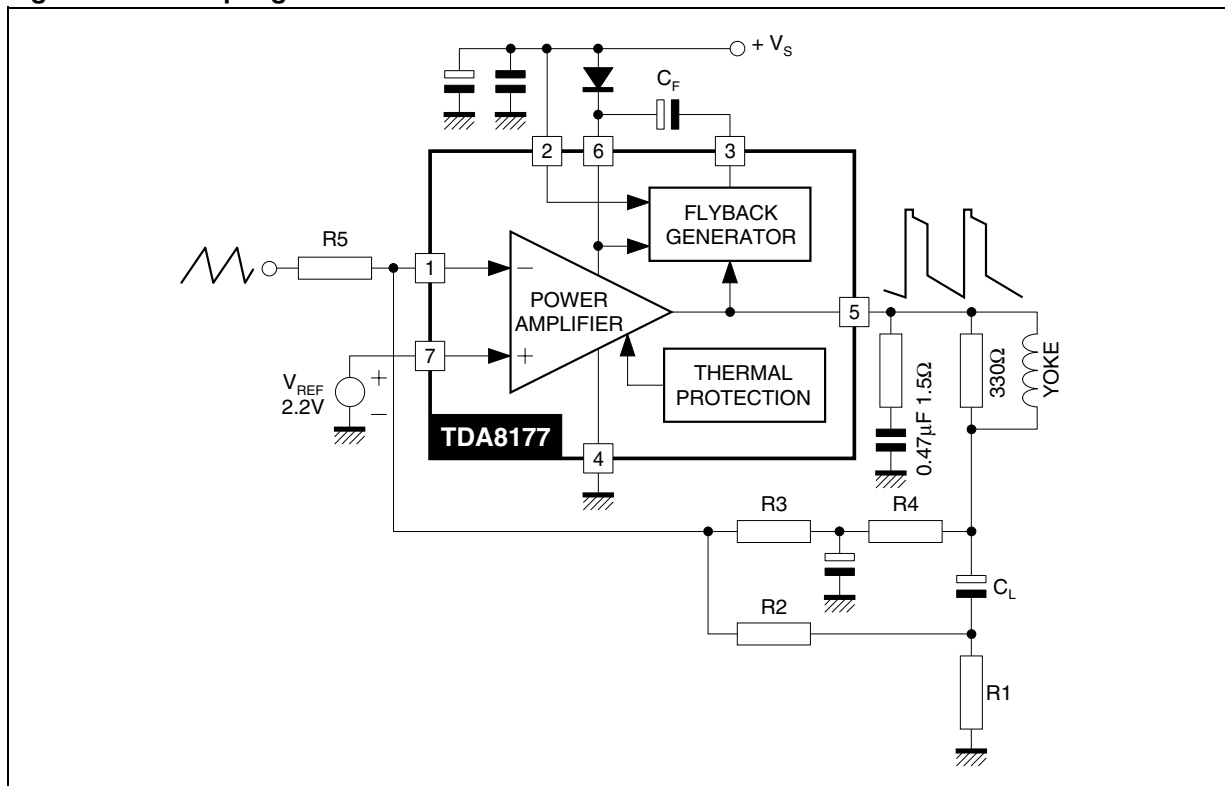

Figure 5. DC Coupling

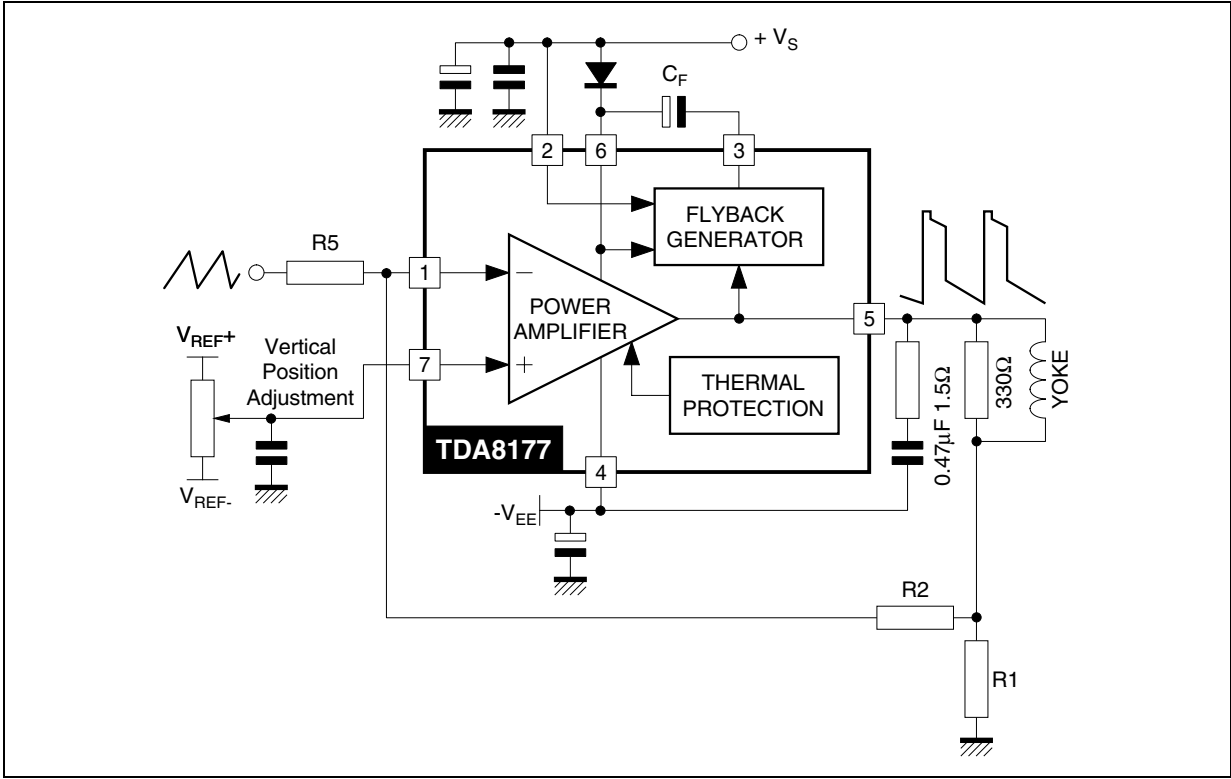

Figure 6. Output Transistors SOA (for secondary breakdown)

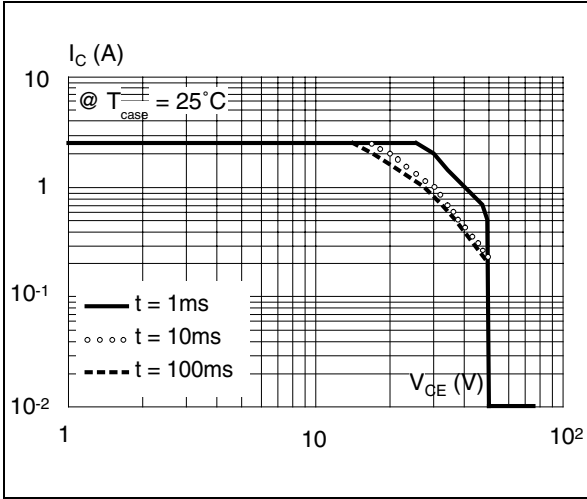
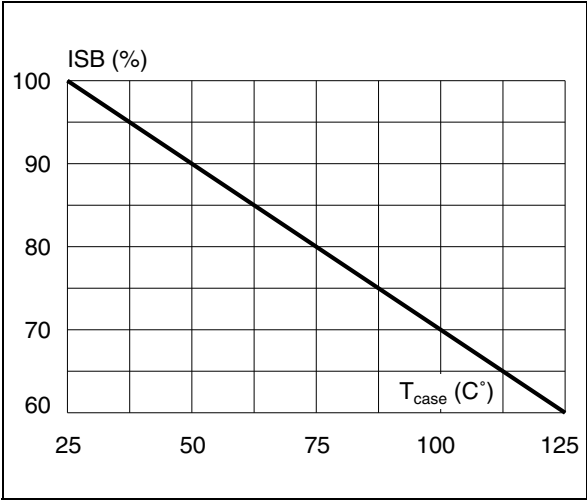

Figure 7. Secondary Breakdown Temperature Derating Curve (ISB = secondary breakdown current)



TDA8177

PART NUMBERING

Table 4. Order Codes

Part Number	Package	Temperature Range
TDA8177	HEPTAWATT7	-20 to 75 °C

PACKAGE MECHANICAL

Table 5. HEPTAWATT7 - Mechanical Data

Symbol	millimeters			inches		
	Min	Typ	Max	Min	Typ	Max
A			4.8			0.189
C			1.37			0.054
D	2.4		2.8	0.094		0.110
D1	1.2		1.35	0.047		0.053
E	0.35		0.55	0.014		0.022
F	0.6		0.8	0.024		0.031
F1			0.9			0.035
G	2.41	2.54	2.67	0.095	0.100	0.105
G1	4.91	5.08	5.21	0.193	0.200	0.205
G2	7.49	7.62	7.8	0.295	0.300	0.307
H2			10.4			0.409
H3	10.05		10.4	0.396		0.409
L		16.97			0.668	
L1		14.92			0.587	
L2		21.54			0.848	
L3		22.62			0.891	
L5	2.6		3	0.102		0.118
L6	15.1		15.8	0.594		0.622
L7	6		6.6	0.236		0.260
M		2.8			0.110	
M1		5.08			0.200	
Dia.	3.65		3.85	0.144		0.152

Figure 8. HEPTAWATT7 - Package Dimensions

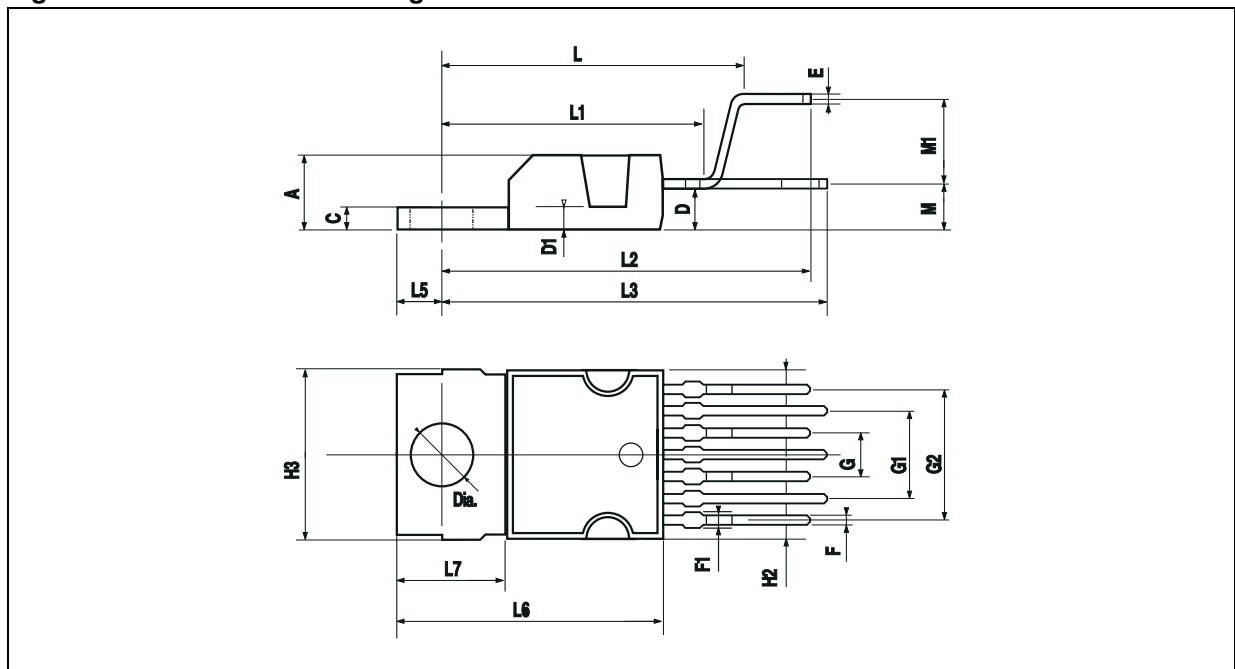

Note: Drawing is not to scale