

120V - 100W DMOS AUDIO AMPLIFIER WITH MUTE/ST-BY

- VERY HIGH OPERATING VOLTAGE RANGE ($\pm 50V$)
- DMOS POWER STAGE
- HIGH OUTPUT POWER (100W @ THD = 10%, $R_L = 8\Omega$, $V_s = \pm 40V$)
- MUTING/STAND-BY FUNCTIONS
- NO SWITCH ON/OFF NOISE
- VERY LOW DISTORTION
- VERY LOW NOISE
- SHORT CIRCUIT PROTECTION
- THERMAL SHUTDOWN
- CLIP DETECTOR
- MODULARITY (MORE DEVICES CAN BE EASILY CONNECTED IN PARALLEL TO DRIVE VERY LOW IMPEDANCES)

MULTIPOWER BCD TECHNOLOGY

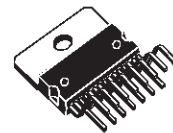

Multiwatt15

ORDERING NUMBER: TDA7293V

class TV). Thanks to the wide voltage range and to the high out current capability it is able to supply the highest power into both 4 Ω and 8 Ω loads.

The built in muting function with turn on delay simplifies the remote operation avoiding switching on-off noises.

Parallel mode is made possible by connecting more device through of pin11. High output power can be delivered to very low impedance loads, so optimizing the thermal dissipation of the system.

DESCRIPTION

The TDA7293 is a monolithic integrated circuit in Multiwatt15 package, intended for use as audio class AB amplifier in Hi-Fi field applications (Home Stereo, self powered loudspeakers, Top-

Figure 1: Typical Application and Test Circuit

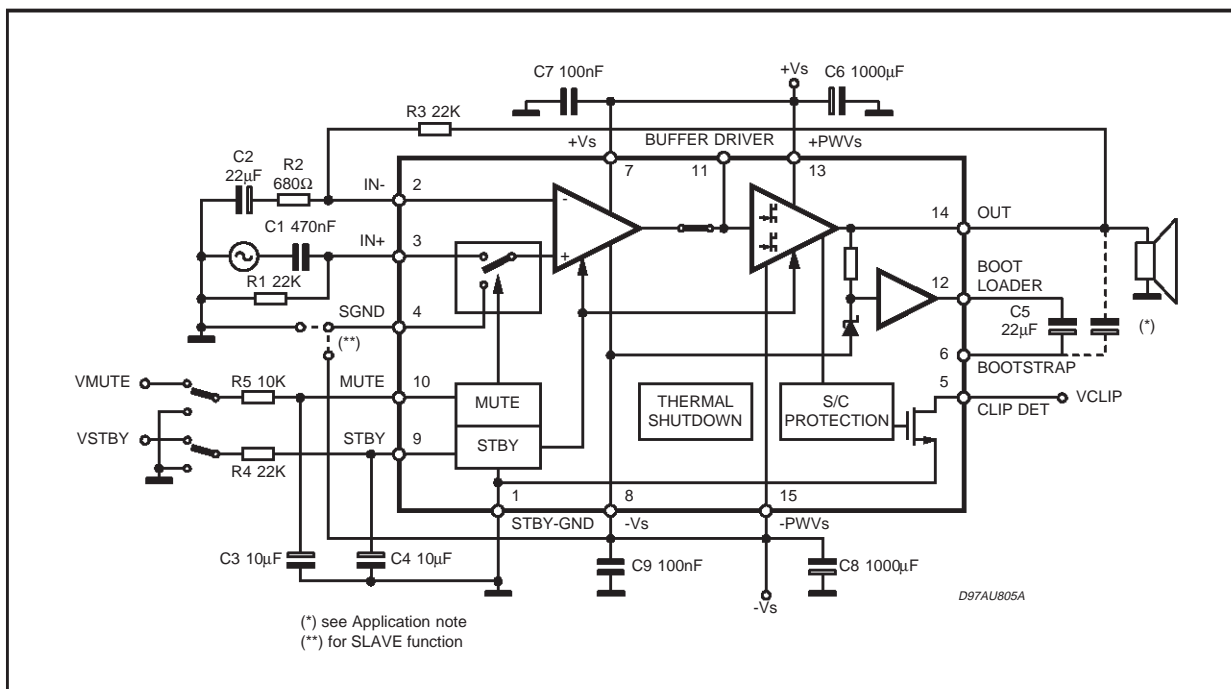

PIN CONNECTION (Top view)

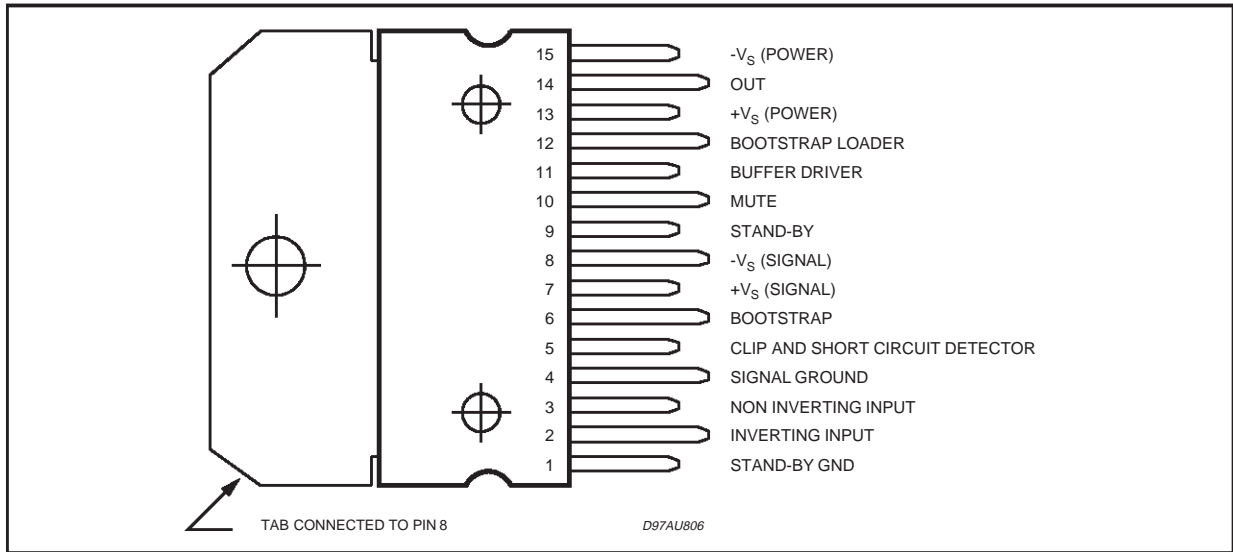

QUICK REFERENCE DATA

| Symbol | Parameter | Test Conditions | Min. | Typ. | Max. | Unit |
|------------|--------------------------|--|----------|------|--------------|------|
| V_S | Supply Voltage Operating | | ± 12 | | ≈ 50 | V |
| G_{LOOP} | Closed Loop Gain | | 26 | | 40 | dB |
| P_{tot} | Output Power | $V_S = \pm 45V; R_L = 8\Omega; THD = 10\%$ | | 140 | | W |
| | | $V_S = \pm 30V; R_L = 4\Omega; THD = 10\%$ | | 110 | | W |
| SVR | Supply Voltage Rejection | | | 75 | | dB |

ABSOLUTE MAXIMUM RATINGS

| Symbol | Parameter | Value | Unit |
|----------------|---|----------|------------|
| V_S | Supply Voltage (No Signal) | ± 60 | V |
| V_1 | $V_{STAND-BY GND}$ Voltage Referred to $-V_S$ (pin 8) | 90 | V |
| V_2 | Input Voltage (inverting) Referred to $-V_S$ | 90 | V |
| $V_2 - V_3$ | Maximum Differential Inputs | ± 30 | V |
| V_3 | Input Voltage (non inverting) Referred to $-V_S$ | 90 | V |
| V_4 | Signal GND Voltage Referred to $-V_S$ | 90 | V |
| V_5 | Clip Detector Voltage Referred to $-V_S$ | 120 | V |
| V_6 | Bootstrap Voltage Referred to $-V_S$ | 120 | V |
| V_9 | Stand-by Voltage Referred to $-V_S$ | 120 | V |
| V_{10} | Mute Voltage Referred to $-V_S$ | 120 | V |
| V_{11} | Buffer Voltage Referred to $-V_S$ | 120 | V |
| V_{12} | Bootstrap Loader Voltage Referred to $-V_S$ | 100 | V |
| I_O | Output Peak Current | 10 | A |
| P_{tot} | Power Dissipation $T_{case} = 70^\circ C$ | 50 | W |
| T_{op} | Operating Ambient Temperature Range | 0 to 70 | $^\circ C$ |
| T_{stg}, T_j | Storage and Junction Temperature | 150 | $^\circ C$ |

THERMAL DATA

| Symbol | Description | Typ | Max | Unit |
|-----------------|----------------------------------|-----|-----|--------------|
| $R_{th j-case}$ | Thermal Resistance Junction-case | 1 | 1.5 | $^\circ C/W$ |

ELECTRICAL CHARACTERISTICS (Refer to the Test Circuit $V_S = \pm 40V$, $R_L = 8\Omega$, $R_G = 50\Omega$; $T_{amb} = 25^\circ C$, $f = 1\text{ kHz}$; unless otherwise specified).

| Symbol | Parameter | Test Condition | Min. | Typ. | Max. | Unit |
|--|--------------------------------|---|----------|------------|----------|--------------------|
| V_S | Supply Range | | ± 12 | | ± 50 | V |
| I_q | Quiescent Current | | | 30 | | mA |
| I_b | Input Bias Current | | | 0.3 | 1 | μA |
| V_{OS} | Input Offset Voltage | | -10 | | 10 | mV |
| I_{OS} | Input Offset Current | | | | 0.2 | μA |
| P_O | RMS Continuous Output Power | d = 1%: $R_L = 4\Omega$; $V_S = \pm 29V$, | | 80 80 | | W |
| | | d = 10% $R_L = 4\Omega$; $V_S = \pm 29V$ | | 100 100 | | W |
| d | Total Harmonic Distortion (**) | $P_O = 5W$; $f = 1\text{ kHz}$ $P_O = 0.1$ to $50W$; $f = 20\text{ Hz}$ to 15 kHz | | 0.005 | 0.1 | % % |
| I_{SC} | Current Limiter Threshold | | | 6.5 | | A |
| SR | Slew Rate | | | 15 | | V/ μs |
| G_V | Open Loop Voltage Gain | | | 80 | | dB |
| G_V | Closed Loop Voltage Gain (1) | | | 30 | | dB |
| e_N | Total Input Noise | A = curve $f = 20\text{ Hz}$ to 20 kHz | | 1 | 5 | μV μV |
| | | | | 2 | | |
| R_i | Input Resistance | | 100 | | | k Ω |
| SVR | Supply Voltage Rejection | $f = 100\text{ Hz}$; $V_{ripple} = 0.5V_{rms}$ | | 75 | | dB |
| T_S | Thermal Protection | DEVICE MUTED | | 150 | | $^\circ C$ |
| | | DEVICE SHUT DOWN | | 160 | | $^\circ C$ |
| STAND-BY FUNCTION (Ref: to pin 1) | | | | | | |
| $V_{ST\ on}$ | Stand-by on Threshold | | | | 1.5 | V |
| $V_{ST\ off}$ | Stand-by off Threshold | | 3.5 | | | V |
| ATT_{st-by} | Stand-by Attenuation | | 70 | 90 | | dB |
| $I_{q\ st-by}$ | Quiescent Current @ Stand-by | | | 0.5 | | mA |
| MUTE FUNCTION (Ref: to pin 1) | | | | | | |
| V_{Mon} | Mute on Threshold | | | | 1.5 | V |
| V_{Moff} | Mute off Threshold | | 3.5 | | | V |
| ATT_{mute} | Mute Attenuation | | 60 | 80 | | dB |
| CLIP DETECTOR | | | | | | |
| Duty | Duty Cycle (pin 5) | THD = 1% ; $R_L = 10K\Omega$ to $5V$ | | 10 | | % |
| | | THD = 10% ; $R_L = 10K\Omega$ to $5V$ | | 40 | | % |
| I_{CLEAK} | | $P_O = 50W$ | | | 1 | μA |
| SLAVE FUNCTION pin 4 (Ref: to pin 8 - V_S) | | | | | | |
| V_{Slave} | SlaveThreshold | | | | 1 | V |
| V_{Master} | Master Threshold | | 3 | | | V |

Note (1): $G_{Vmin} \geq 26\text{ dB}$

Note: Pin 11 only for modular connection. Max external load $1M\Omega/10\text{ pF}$, only for test purpose

Note ():** Tested with optimized Application Board (see fig. 2)

Figure 2: Typical Application P.C. Board and Component Layout (scale 1:1)

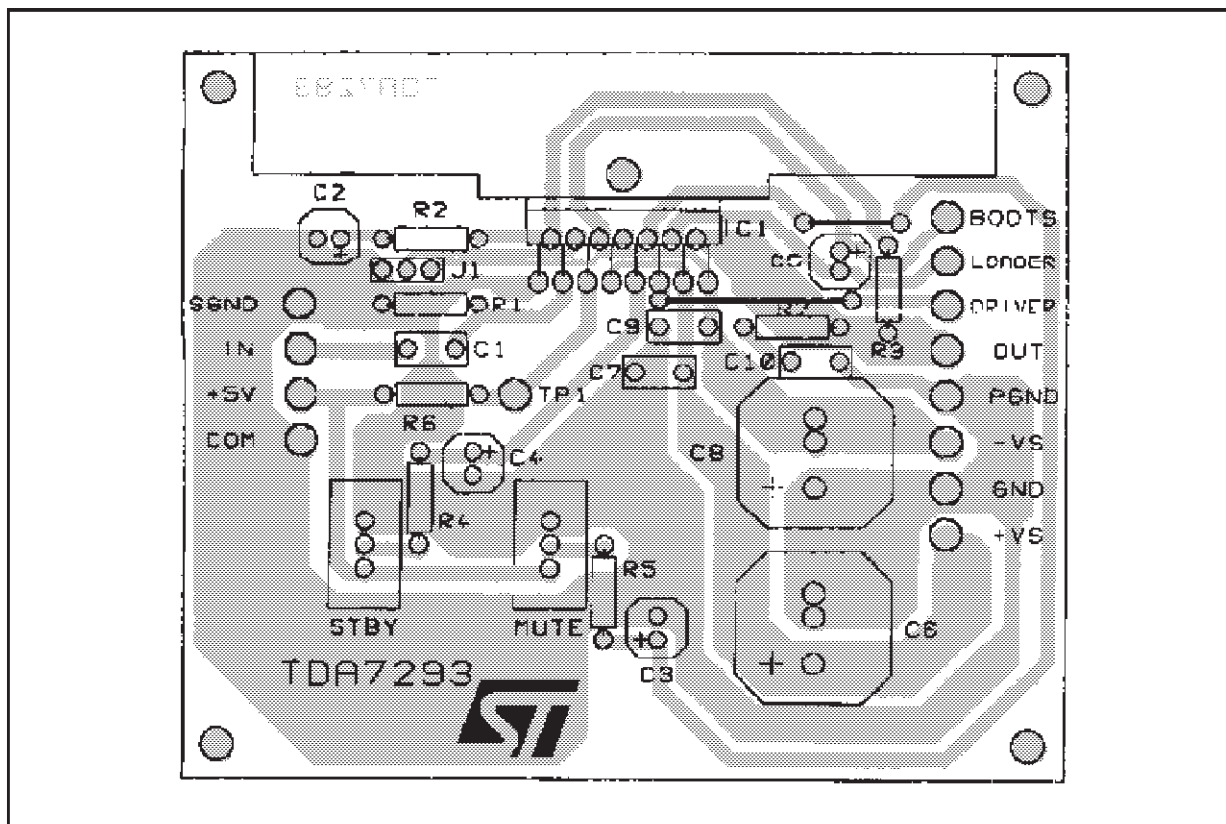

APPLICATION SUGGESTIONS (see Test and Application Circuits of the Fig. 1)

The recommended values of the external components are those shown on the application circuit of Figure 1. Different values can be used; the following table can help the designer.

| COMPONENTS | SUGGESTED VALUE | PURPOSE | LARGER THAN SUGGESTED | SMALLER THAN SUGGESTED |
|------------|--------------------|-----------------------------------|--------------------------|--------------------------------------|
| R1 (*) | 22k | INPUT RESISTANCE | INCREASE INPUT IMPEDANCE | DECREASE INPUT IMPEDANCE |
| R2 | 680 Ω | CLOSED LOOP GAIN SET TO 30dB (**) | DECREASE OF GAIN | INCREASE OF GAIN |
| R3 (*) | 22k | | INCREASE OF GAIN | DECREASE OF GAIN |
| R4 | 22k | ST-BY TIME CONSTANT | LARGER ST-BY ON/OFF TIME | SMALLER ST-BY ON/OFF TIME; POP NOISE |
| R5 | 10k | MUTE TIME CONSTANT | LARGER MUTE ON/OFF TIME | SMALLER MUTE ON/OFF TIME |
| C1 | 0.47 μ F | INPUT DC DECOUPLING | | HIGHER LOW FREQUENCY CUTOFF |
| C2 | 22 μ F | FEEDBACK DC DECOUPLING | | HIGHER LOW FREQUENCY CUTOFF |
| C3 | 10 μ F | MUTE TIME CONSTANT | LARGER MUTE ON/OFF TIME | SMALLER MUTE ON/OFF TIME |
| C4 | 10 μ F | ST-BY TIME CONSTANT | LARGER ST-BY ON/OFF TIME | SMALLER ST-BY ON/OFF TIME; POP NOISE |
| C5 | 22 μ FXN (***) | BOOTSTRAPPING | | SIGNAL DEGRADATION AT LOW FREQUENCY |
| C6, C8 | 1000 μ F | SUPPLY VOLTAGE BYPASS | | |
| C7, C9 | 0.1 μ F | SUPPLY VOLTAGE BYPASS | | DANGER OF OSCILLATION |

(*) R1 = R3 for pop optimization

(**) Closed Loop Gain has to be ≥ 26 dB

(***) Multiplay this value for the number of modular part connected

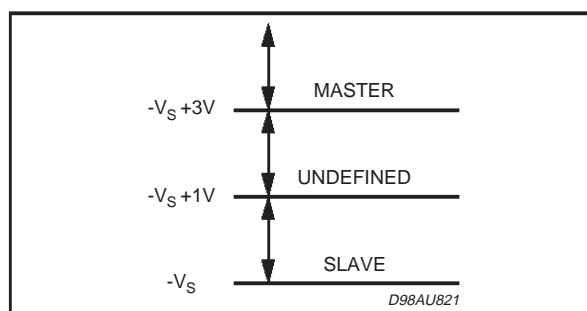
Slave function: pin 4 (Ref to pin 8 -V_S)**Note:**

If in the application, the speakers are connected via long wires, it is a good rule to add between the output and GND, a Boucherot Cell, in order to avoid dangerous spurious oscillations when the speakers terminal are shorted.

The suggested Boucherot Resistor is 3.9 Ω /2W and the capacitor is 1 μ F.

INTRODUCTION

In consumer electronics, an increasing demand has arisen for very high power monolithic audio amplifiers able to match, with a low cost, the performance obtained from the best discrete designs.

The task of realizing this linear integrated circuit in conventional bipolar technology is made extremely difficult by the occurrence of 2nd breakdown phenomenon. It limits the safe operating area (SOA) of the power devices, and, as a consequence, the maximum attainable output power, especially in presence of highly reactive loads.

Moreover, full exploitation of the SOA translates into a substantial increase in circuit and layout complexity due to the need of sophisticated protection circuits.

To overcome these substantial drawbacks, the use of power MOS devices, which are immune from secondary breakdown is highly desirable.

The device described has therefore been developed in a mixed bipolar-MOS high voltage technology called BCDII 100/120.

1) Output Stage

The main design task in developing a power operational amplifier, independently of the technology used, is that of realization of the output stage.

The solution shown as a principle schematic by Fig3 represents the DMOS unity - gain output buffer of the TDA7293.

This large-signal, high-power buffer must be capable of handling extremely high current and voltage levels while maintaining acceptably low harmonic distortion and good behaviour over

frequency response; moreover, an accurate control of quiescent current is required.

A local linearizing feedback, provided by differential amplifier A, is used to fulfill the above requirements, allowing a simple and effective quiescent current setting.

Proper biasing of the power output transistors alone is however not enough to guarantee the absence of crossover distortion.

While a linearization of the DC transfer characteristic of the stage is obtained, the dynamic behaviour of the system must be taken into account.

A significant aid in keeping the distortion contributed by the final stage as low as possible is provided by the compensation scheme, which exploits the direct connection of the Miller capacitor at the amplifier's output to introduce a local AC feedback path enclosing the output stage itself.

2) Protections

In designing a power IC, particular attention must be reserved to the circuits devoted to protection of the device from short circuit or overload conditions.

Due to the absence of the 2nd breakdown phenomenon, the SOA of the power DMOS transistors is delimited only by a maximum dissipation curve dependent on the duration of the applied stimulus.

In order to fully exploit the capabilities of the power transistors, the protection scheme implemented in this device combines a conventional SOA protection circuit with a novel local temperature sensing technique which "dynamically" controls the maximum dissipation.

Figure 3: Principle Schematic of a DMOS unity-gain buffer.

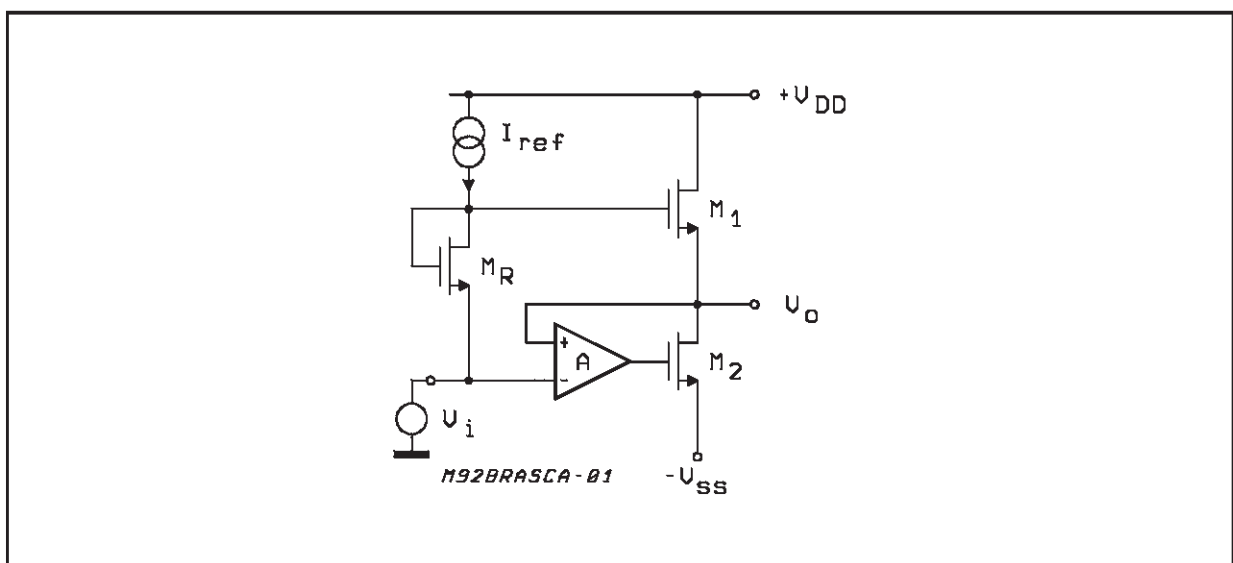
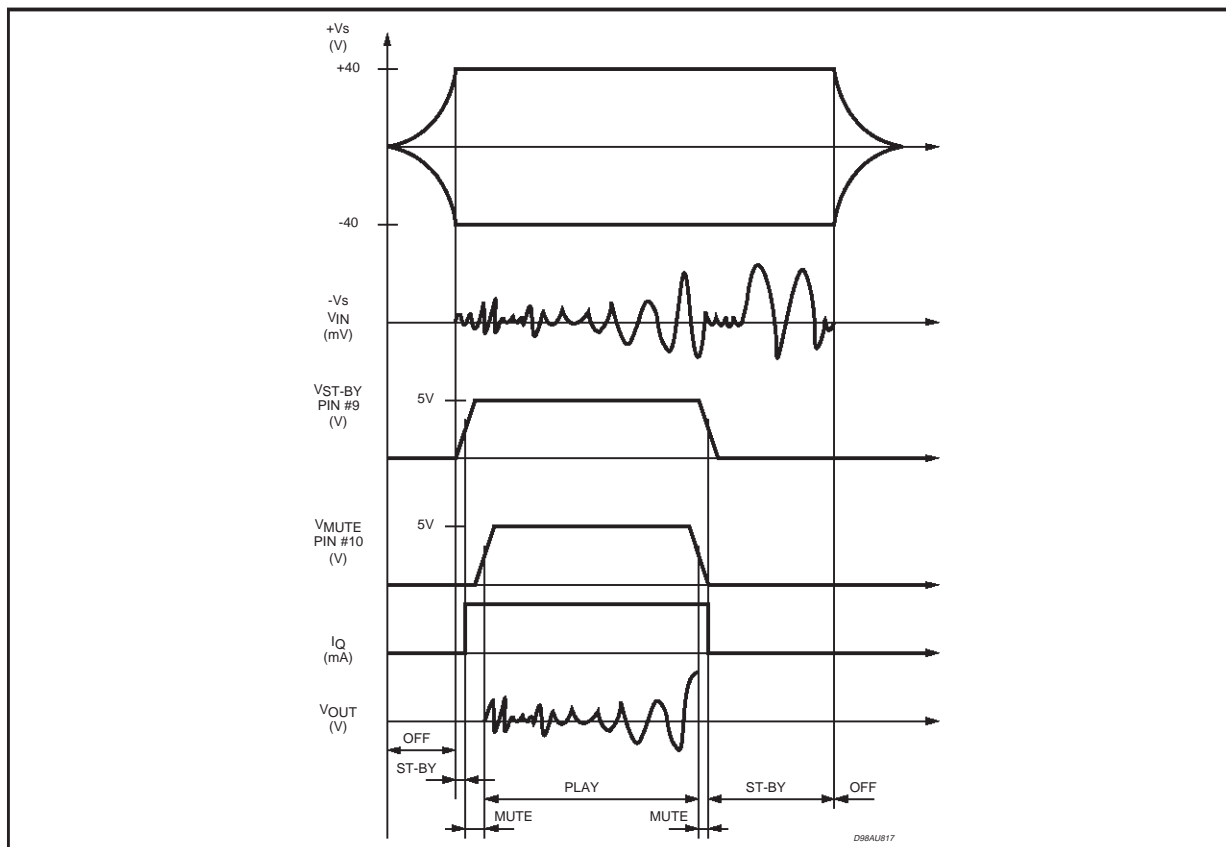

Figure 4: Turn ON/OFF Suggested Sequence



In addition to the overload protection described above, the device features a thermal shutdown circuit which initially puts the device into a muting state (@ $T_j = 150\text{ }^\circ\text{C}$) and then into stand-by (@ $T_j = 160\text{ }^\circ\text{C}$).

Full protection against electrostatic discharges on every pin is included.

Figure 5: Single Signal ST-BY/MUTE Control Circuit

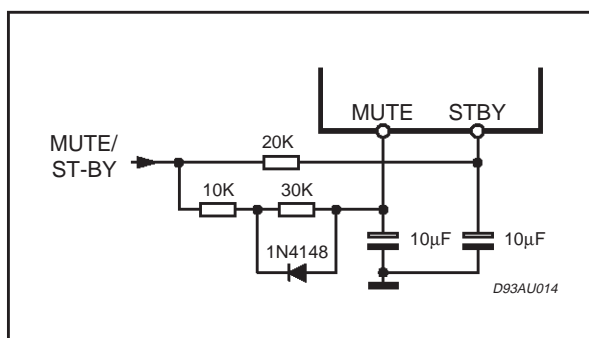

3) Other Features

The device is provided with both stand-by and

mute functions, independently driven by two CMOS logic compatible input pins.

The circuits dedicated to the switching on and off of the amplifier have been carefully optimized to avoid any kind of uncontrolled audible transient at the output.

The sequence that we recommend during the ON/OFF transients is shown by Figure 4.

The application of figure 5 shows the possibility of using only one command for both st-by and mute functions. On both the pins, the maximum applicable range corresponds to the operating supply voltage.

APPLICATION INFORMATION

HIGH-EFFICIENCY

Constraints of implementing high power solutions are the power dissipation and the size of the power supply. These are both due to the low efficiency of conventional AB class amplifier approaches.

Here below (figure 6) is described a circuit proposal for a high efficiency amplifier which can be adopted for both HI-FI and CAR-RADIO applications.

The TDA7293 is a monolithic MOS power amplifier which can be operated at 100V supply voltage (120V with no signal applied) while delivering output currents up to ± 6.5 A.

This allows the use of this device as a very high power amplifier (up to 180W as peak power with T.H.D.=10 % and $R_L = 4$ Ohm); the only drawback is the power dissipation, hardly manageable in the above power range.

The typical junction-to-case thermal resistance of the TDA7293 is 1 °C/W (max= 1.5 °C/W). To avoid that, in worst case conditions, the chip temperature exceeds 150 °C, the thermal resistance of the heatsink must be 0.038 °C/W (@ max ambient temperature of 50 °C).

As the above value is practically unreachable; a high efficiency system is needed in those cases where the continuous RMS output power is higher than 50-60 W.

The TDA7293 was designed to work also in higher efficiency way.

For this reason there are four power supply pins: two intended for the signal part and two for the power part.

T1 and T2 are two power transistors that only operate when the output power reaches a certain threshold (e.g. 20 W). If the output power increases, these transistors are switched on during the portion of the signal where more output voltage swing is needed, thus "bootstrapping" the power supply pins (#13 and #15).

The current generators formed by T4, T7, zener diodes Z1, Z2 and resistors R7,R8 define the minimum drop across the power MOS transistors of the TDA7293. L1, L2, L3 and the snubbers C9, R1 and C10, R2 stabilize the loops formed by the "bootstrap" circuits and the output stage of the TDA7293.

By considering again a maximum average output power (music signal) of 20W, in case of the high efficiency application, the thermal resistance value needed from the heatsink is 2.2 °C/W ($V_s = \pm 50$ V and $R_L = 8$ Ohm).

All components (TDA7293 and power transistors T1 and T2) can be placed on a 1.5 °C/W heatsink, with the power darlington's electrically insulated from the heatsink.

Since the total power dissipation is less than that of a usual class AB amplifier, additional cost savings can be obtained while optimizing the power supply, even with a high heatsink.

BRIDGE APPLICATION

Another application suggestion is the BRIDGE configuration, where two TDA7293 are used.

In this application, the value of the load must not be lower than 8 Ohm for dissipation and current capability reasons.

A suitable field of application includes HI-FI/TV subwoofers realizations.

The main advantages offered by this solution are:

- High power performances with limited supply voltage level.
- Considerably high output power even with high load values (i.e. 16 Ohm).

With $R_L = 8$ Ohm, $V_s = \pm 25$ V the maximum output power obtainable is 150 W, while with $R_L = 16$ Ohm, $V_s = \pm 40$ V the maximum P_{out} is 200 W.

APPLICATION NOTE: (ref. fig. 7)

Modular Application (more Devices in Parallel)

The use of the modular application lets very high power be delivered to very low impedance loads. The modular application implies one device to act as a master and the others as slaves.

The slave power stages are driven by the master device and work in parallel all together, while the input and the gain stages of the slave device are disabled, the figure below shows the connections required to configure two devices to work together.

- The master chip connections are the same as the normal single ones.
- The outputs can be connected together **without the need of any ballast resistance**.
- The slave SGND pin must be tied to the negative supply.
- The slave ST-BY pin must be connected to ST-BY pin.
- The bootstrap lines must be connected together and the bootstrap capacitor must be increased: for N devices the bootstrap capacitor must be $22\mu\text{F}$ times N.
- The slave Mute and IN-pins must be grounded.

THE BOOTSTRAP CAPACITOR

For compatibility purpose with the previous devices of the family, the bootstrap capacitor can be connected both between the bootstrap pin (6) and the output pin (14) or between the bootstrap pin (6) and the bootstrap loader pin (12).

When the bootcap is connected between pin 6 and 14, the maximum supply voltage in presence of output signal is limited to 100V, due the bootstrap capacitor overvoltage.

When the bootcap is connected between pins 6 and 12 the maximum supply voltage extend to the full voltage that the technology can stand: 120V.

This is accomplished by the clamp introduced at the bootstrap loader pin (12): this pin follows the output voltage up to 100V and remains clamped at 100V for higher output voltages. This feature lets the output voltage swing up to a gate-source voltage from the positive supply ($V_s - 3$ to 6V)

Figure 6: High Efficiency Application Circuit

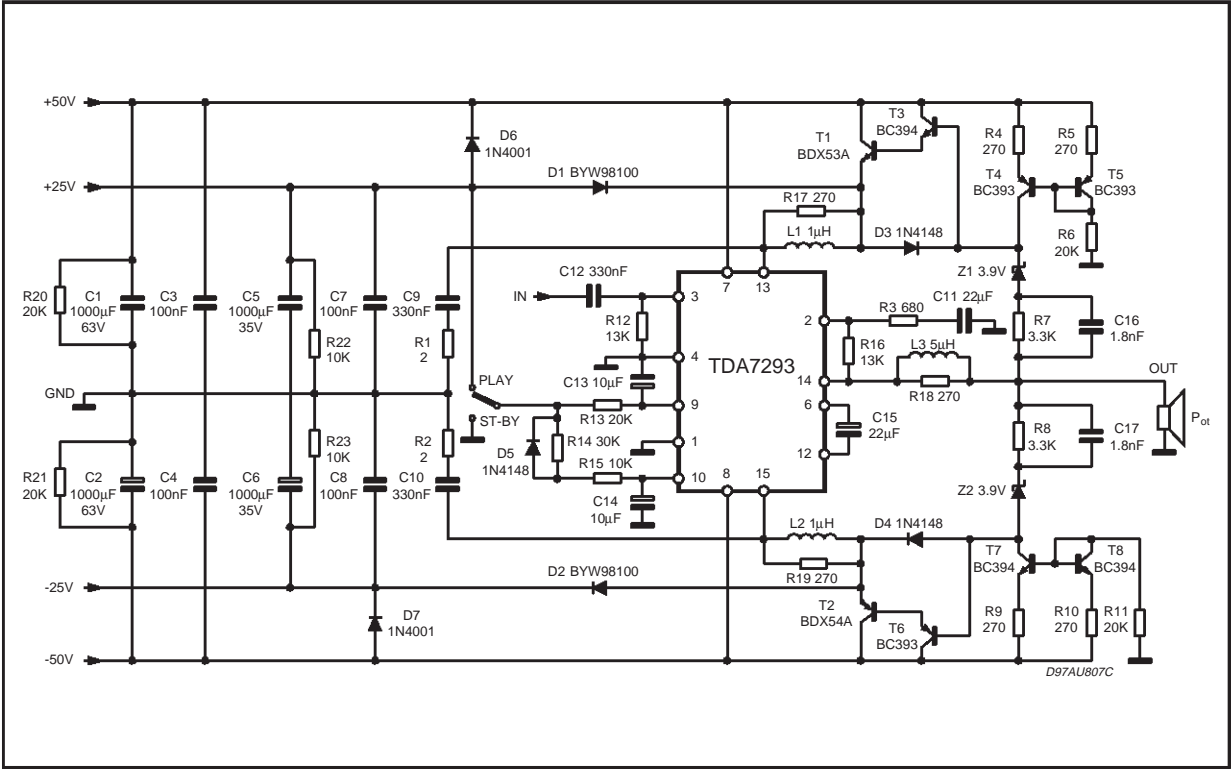

Figure 6a: PCB and Component Layout of the fig. 6

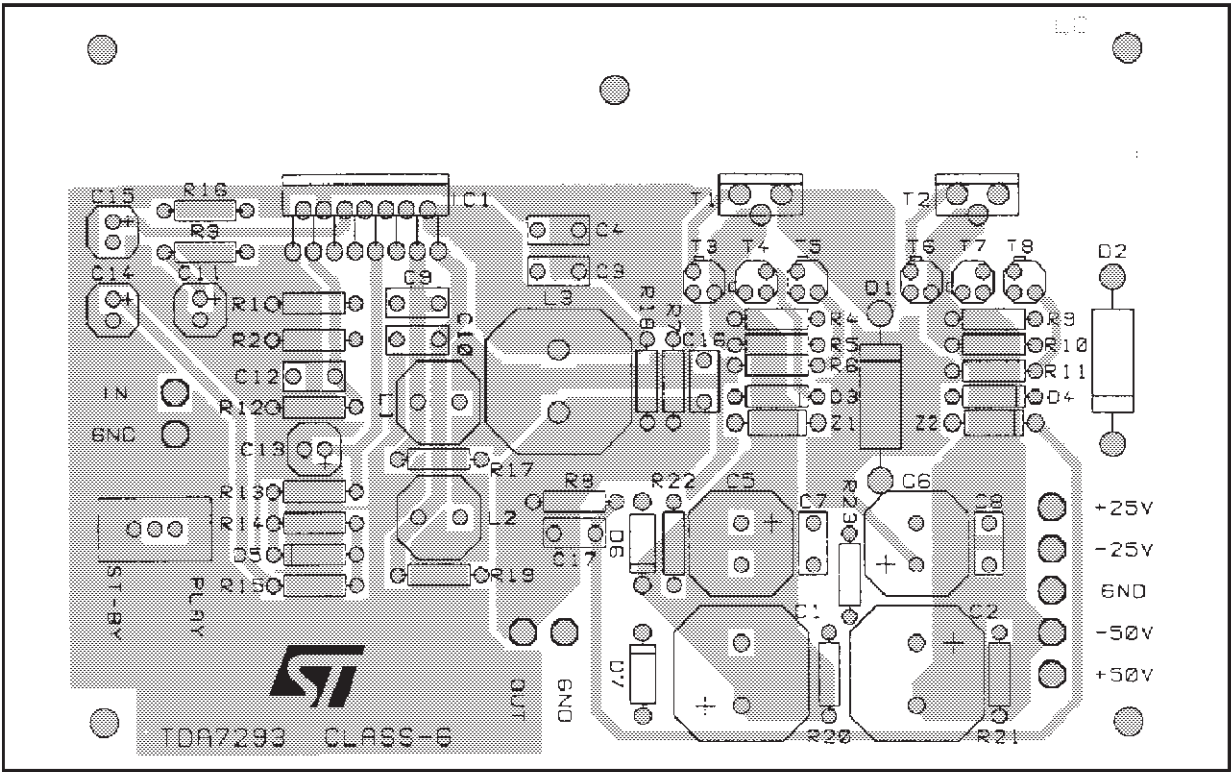

Figure 6b: PCB - Solder Side of the fig. 6.

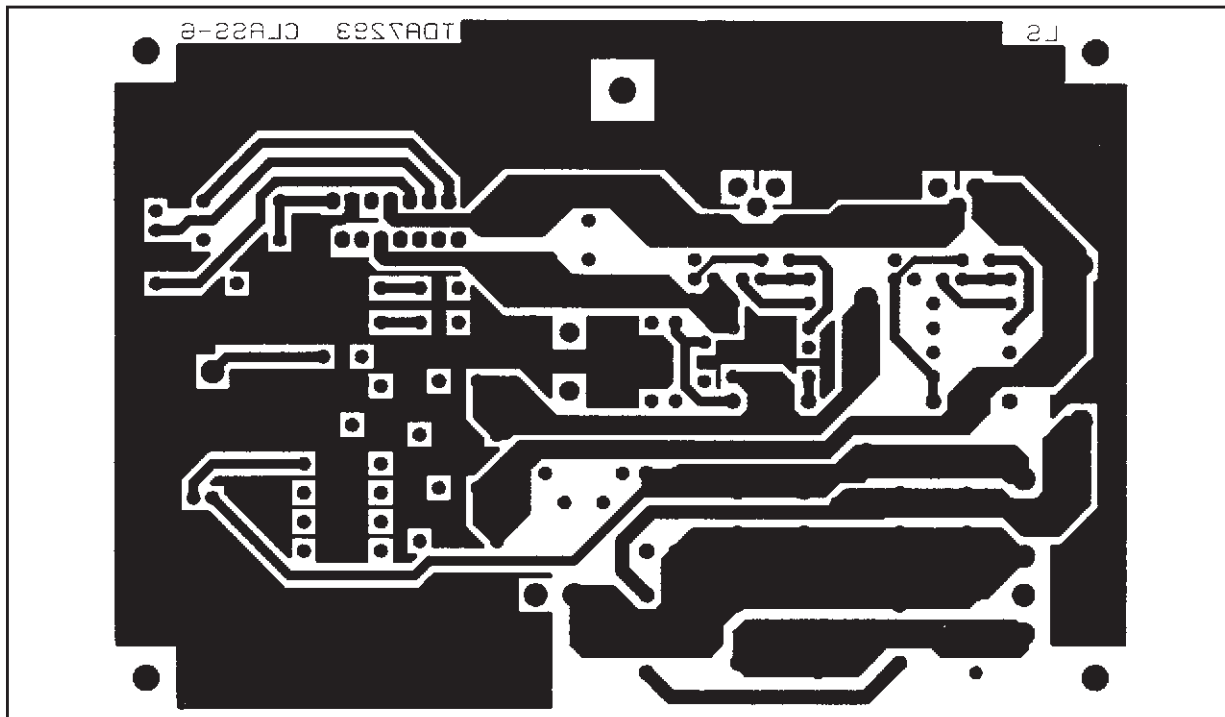

Figure 7: Modular Application Circuit

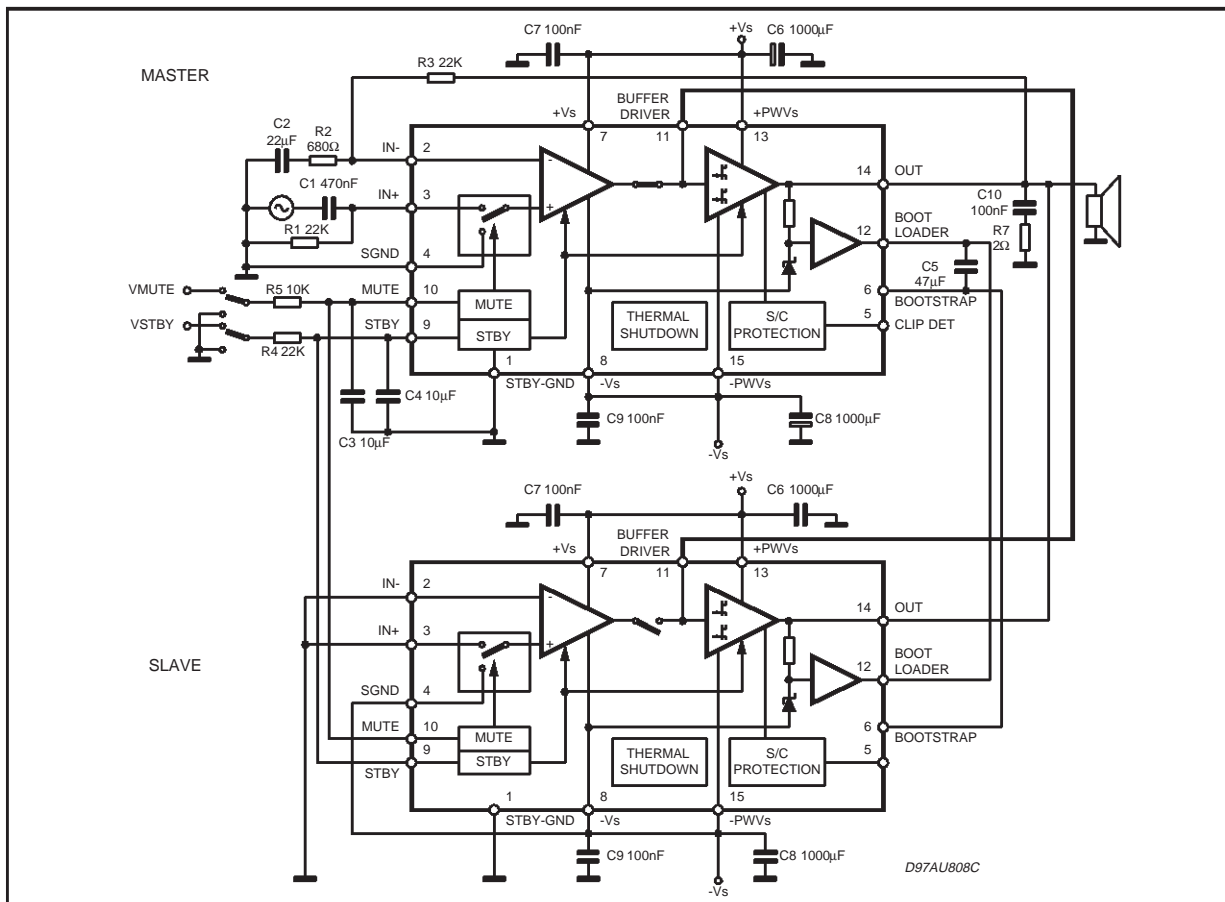

Figure 8a: Modular Application P.C. Board and Component Layout (scale 1:1) (Component SIDE)

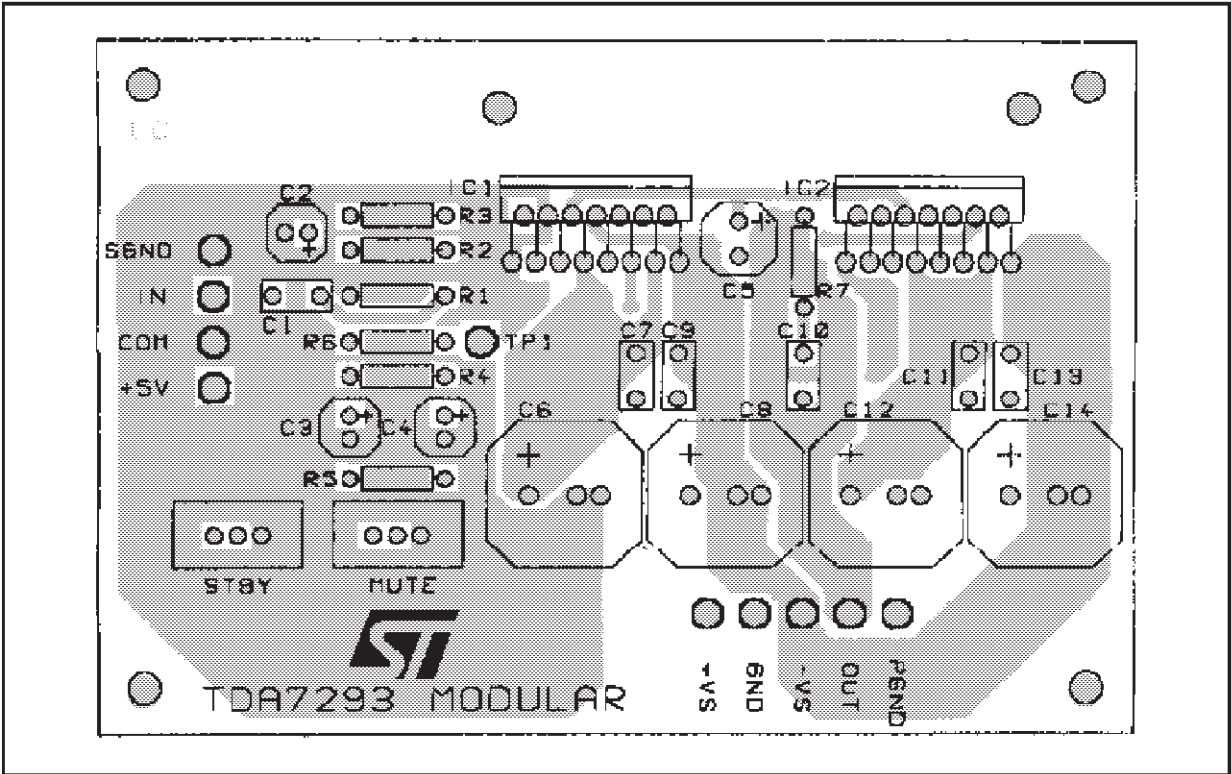
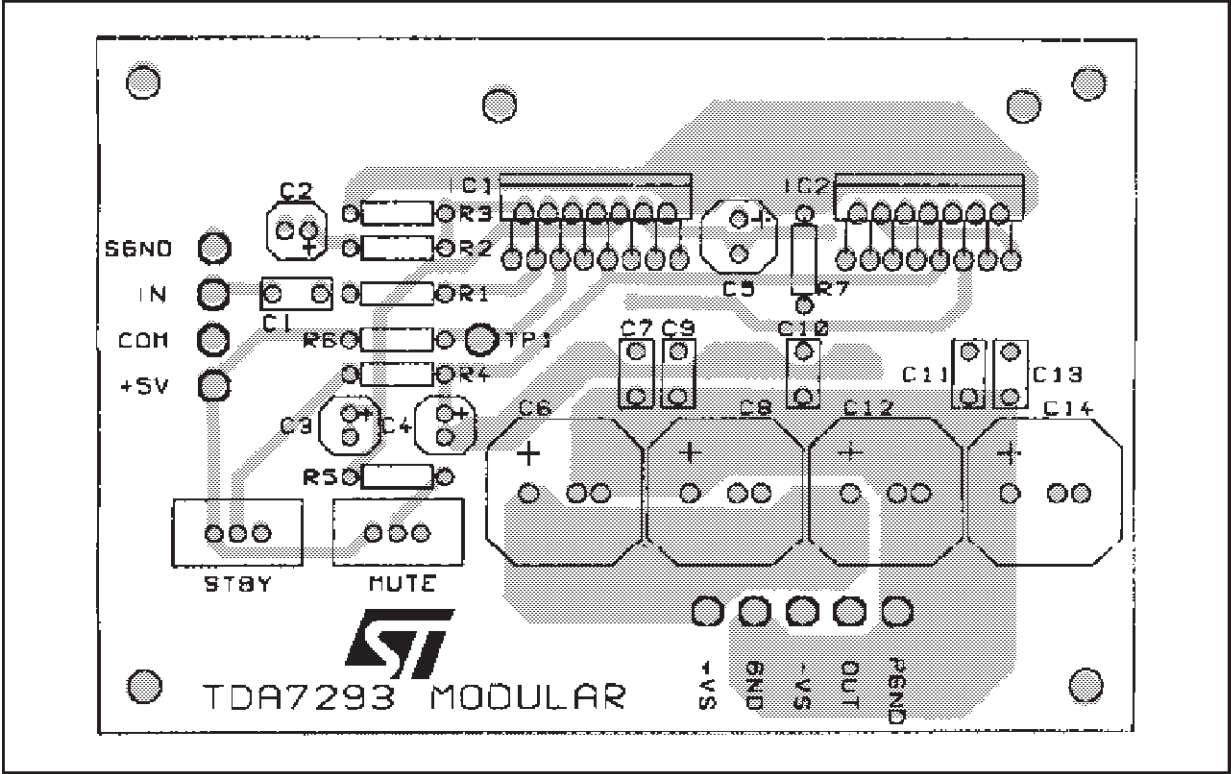
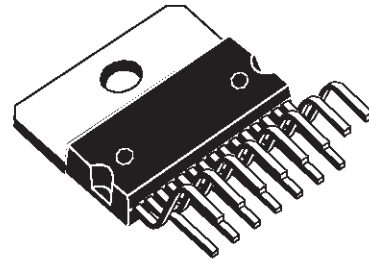

Figure 8b: Modular Application P.C. Board and Component Layout (scale 1:1) (Solder SIDE)



| DIM. | mm | | | inch | | |
|------|-------|-------|-------|-------|-------|-------|
| | MIN. | TYP. | MAX. | MIN. | TYP. | MAX. |
| A | | | 5 | | | 0.197 |
| B | | | 2.65 | | | 0.104 |
| C | | | 1.6 | | | 0.063 |
| D | | 1 | | | 0.039 | |
| E | 0.49 | | 0.55 | 0.019 | | 0.022 |
| F | 0.66 | | 0.75 | 0.026 | | 0.030 |
| G | 1.02 | 1.27 | 1.52 | 0.040 | 0.050 | 0.060 |
| G1 | 17.53 | 17.78 | 18.03 | 0.690 | 0.700 | 0.710 |
| H1 | 19.6 | | | 0.772 | | |
| H2 | | | 20.2 | | | 0.795 |
| L | 21.9 | 22.2 | 22.5 | 0.862 | 0.874 | 0.886 |
| L1 | 21.7 | 22.1 | 22.5 | 0.854 | 0.870 | 0.886 |
| L2 | 17.65 | | 18.1 | 0.695 | | 0.713 |
| L3 | 17.25 | 17.5 | 17.75 | 0.679 | 0.689 | 0.699 |
| L4 | 10.3 | 10.7 | 10.9 | 0.406 | 0.421 | 0.429 |
| L7 | 2.65 | | 2.9 | 0.104 | | 0.114 |
| M | 4.25 | 4.55 | 4.85 | 0.167 | 0.179 | 0.191 |
| M1 | 4.63 | 5.08 | 5.53 | 0.182 | 0.200 | 0.218 |
| S | 1.9 | | 2.6 | 0.075 | | 0.102 |
| S1 | 1.9 | | 2.6 | 0.075 | | 0.102 |
| Dia1 | 3.65 | | 3.85 | 0.144 | | 0.152 |

OUTLINE AND MECHANICAL DATA



Multiwatt15 V

