

60 W HI-FI DUAL AUDIO DRIVER

- WIDE SUPPLY VOLTAGE RANGE : 20 TO 90 V (± 10 to ± 45 V)
- VERY LOW DISTORTION
- AUTOMATIC QUIESCENT CURRENT CONTROL FOR THE POWER TRANSISTORS WITHOUT TEMPERATURE SENSE ELEMENTS
- OVERLOAD CURRENT PROTECTION FOR THE POWER TRANSISTORS
- MUTE/STAND-BY FUNCTIONS
- LOW POWER CONSUMPTION
- OUTPUT POWER 60 W/8 Ω AND 100 W/4 Ω

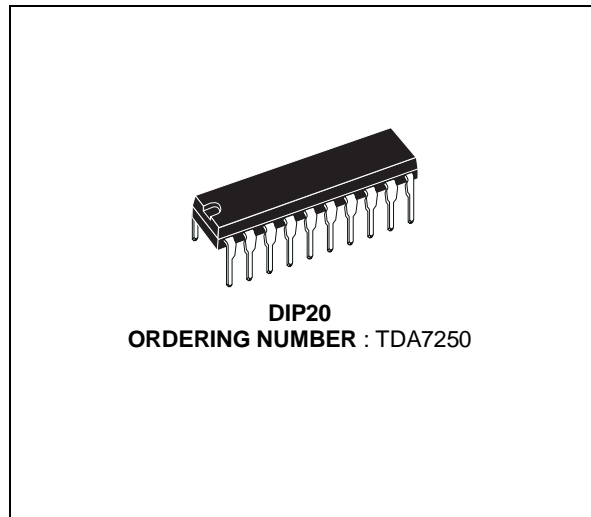

DESCRIPTION

The TDA7250 stereo audio driver is designed to drive two pair of complementary output transistor in the Hi-Fi power amplifiers.

APPLICATION CIRCUIT

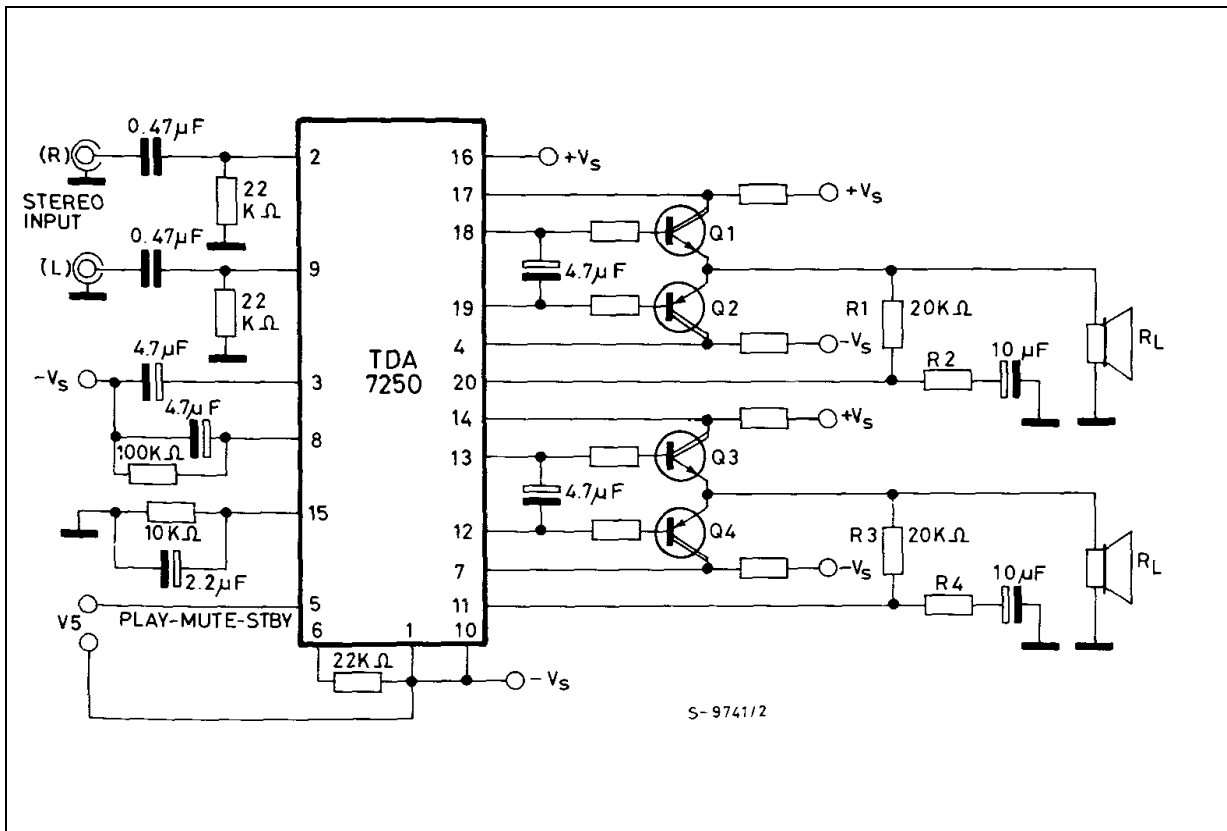

TDA7250

PIN CONNECTION (top view)

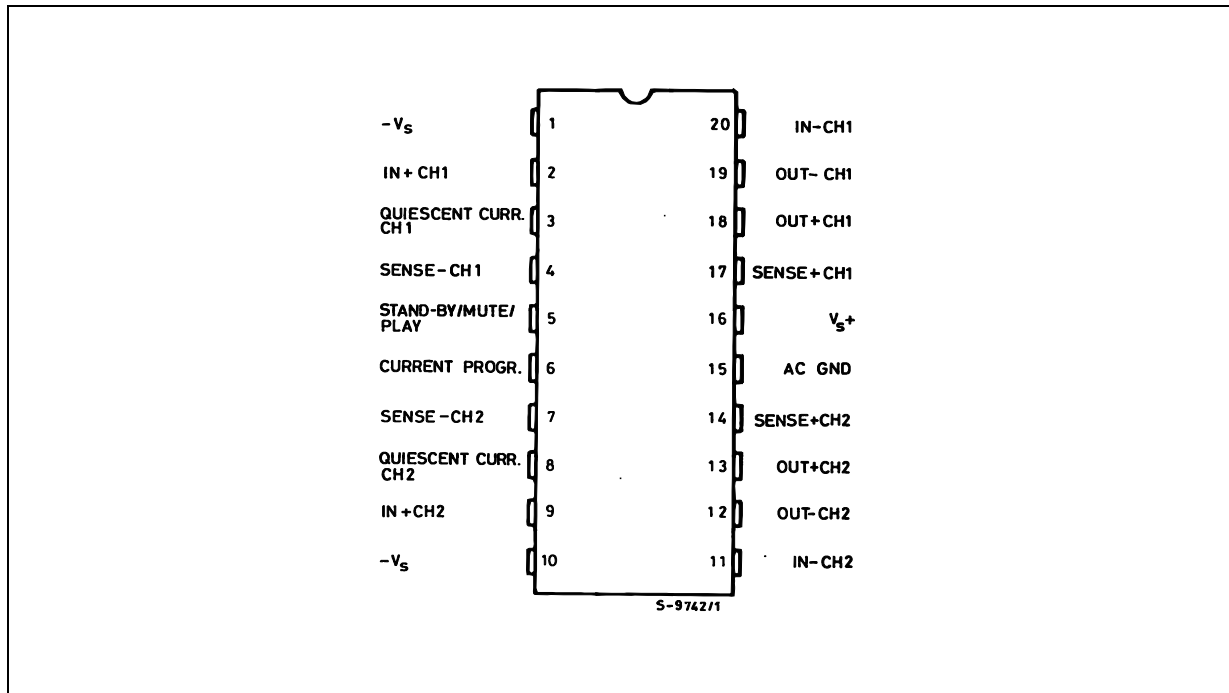

ABSOLUTE MAXIMUM RATINGS

Symbol	Parameter	Value	Unit
V_s	Supply Voltage	100	V
P_{tot}	Power Dissipation at $T_{amb} = 60\text{ }^\circ\text{C}$	1.4	W
T_j, T_{stg}	Storage and Junction Temperature	- 40 to + 150	$^\circ\text{C}$

THERMAL DATA

Symbol	Parameter	Value	Unit
$R_{th\ j-amb}$	Thermal Resistance Junction-ambient	Max. 65	$^\circ\text{C/W}$

PIN FUNCTIONS

N°	Name	Function
1	V _S – POWER SUPPLY	Negative Supply Voltage.
2	NON-INV. INP. CH. 1	Channel 1 Input Signal.
3	QUIESC. CURRENT CONTR. CAP. CH1	This capacitor works as an integrator, to control the quiescent current to output devices in no-signal conditions on channel 1.
4	SENSE (-) CH. 1	Negative voltage sense input for overload protection and for automatic quiescent current control.
5	ST. BY / MUTE / PLAY	Three-functions Terminal. For V _{IN} = 1 to 3 V, the device is in MUTE and only quiescent current flows in the power stages ; - for V _{IN} < 1 V, the device is in STAND-BY mode and no quiescent current is present in the power stages ; - for V _{IN} > 3 V, the device
6	CURRENT PROGRAM	High Impedance Power-stages Monitor.
7	SENSE (-) CH. 2	Negative Voltage Sense Input for Overload Protection and for Automatic Quiescent Current Control.
8	QUIESC. CURRENT CONTR. CAP. CH. 2	This capacitor works as an integrator, to control the quiescent current to output devices in no-signal conditions on channel 2. If the voltage at its terminals drops under 250 mV, it also resets the device from high-impedance state of output stages.
9	NON-INV. INP. CH. 2	Channel 2 Input Signals.
10	V _S – POWER SUPPLY	Negative Supply Voltage.
11	INVERT. INP. CH. 2	Feedback from Output (channel 2).
12	OUT (-) CH. 2	Out Signal to Lower Driver Transistor of Channel 2.
13	OUT (+) CH. 2	Out Signal to Higher Driver Transistor of Channel 2.
14	SENSE (+) CH. 2	Positive Voltage Sense Input for Overload Protection and for Automatic Quiescent Current Control.
15	COMMON AC GROUND	AC Input Ground in MUTE Condition.
16	V _S + POWER SUPPLY	Positive Supply Voltage.
17	SENSE (+) CH. 1	Positive Voltage Sense Input for Overload Protection and for Automatic Quiescent Current Control.
18	OUT (+) CH. 1	Out Signal to High Driver Transistor of Channel 1.
19	OUT (-) CH. 1	Out Signal to Low Driver Transistor of Channel 1.
20	INVERT. INP. CH. 1	Feedback from Output (channel 1).

BLOCK DIAGRAM

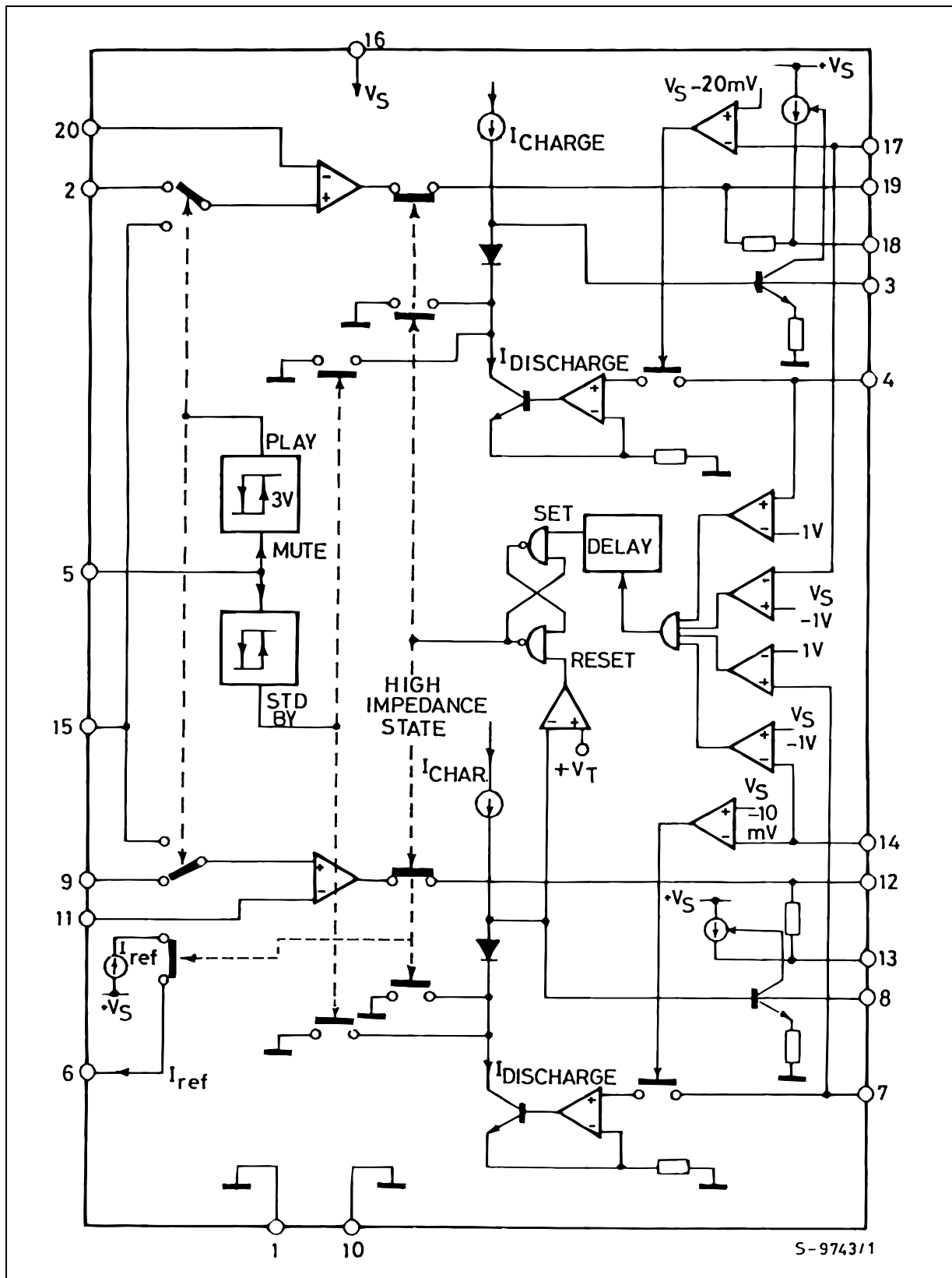

ELECTRICAL CHARACTERISTICS ($T_{amb} = 25\text{ }^{\circ}\text{C}$, $V_s = \pm 35\text{ V}$, play mode, unless otherwise specified)

Symbol	Parameter	Test Conditions	Min.	Typ.	Max.	Unit
V_s	Supply Voltage		± 10		± 45	V
I_d	Quiescent Drain Current	Stand-by Mode		8		mA
		Play Mode		10	14	
I_b	Input Bias Current			0.2	1	μA
V_{os}	Input Offset Voltage			1	± 10	mV
I_{os}	Input Offset Current			100	200	nA
G_v	Open Loop Voltage Gain	$f = 100\text{ Hz}$		90		dB
		$f = 10\text{ kHz}$		60		
e_N	Input Noise Voltage	$R_G = 600\ \Omega$ $B = 20\text{ Hz to } 20\text{ kHz}$		3		μV
SR	Slew Rate			10		V/ μs
d	Total Harmonic Distortion	$G_v = 26\text{ dB}$, $P_o = 40\text{ W}$ $f = 1\text{ kHz}$ $f = 20\text{ kHz}$		0.004		%
				0.03		%
V_{opp}	Output Voltage Swing			60		V_{pp}
P_o	Output Power (*)	$V_s = \pm 35\text{ V}$, $R_L = 8\ \Omega$ $V_s = \pm 30\text{ V}$, $R_L = 8\ \Omega$ $V_s = \pm 35\text{ V}$, $R_L = 4\ \Omega$		60		W
				40		W
				100		W
I_o	Output Current			± 5		mA
SVR	Supply Voltage Rejection	$f = 100\text{ Hz}$		75		dB
C_s	Channel Separation	$f = 1\text{ kHz}$		75		dB

MUTE / STANDBY/ PLAY FUNCTIONS

Symbol	Parameter	Test Conditions	Min.	Typ.	Max.	Unit
I_i	Input Current (pin 5)			0.1		μA
V_{th}	Comparator Standby / Mute Threshold (**)		1.0	1.25	1.5	V
H	Hysteresis Standby / Mute			200		mV
V_{th}	Comparator Mute / Play Threshold (**)		2.4	3.0	3.6	V
H	Hysteresis Mute / Play			300		mV
	Mute Attenuation	$f = 1\text{ kHz}$		60		dB
V_i	Input Voltage Max. (pin 5)		12 (**)			V

(*) Application circuit of fig. 1 $f = 1\text{ KHz}$; $d = 0.1\%$; $G_v = 26\text{ dB}$.

(**) Referred to $-V_s$.

CURRENT SURVEY CIRCUITRY

Symbol	Parameter	Test Conditions	Min.	Typ.	Max.	Unit
	Comparator Reference	to $+V_s$	0.8	1	1.4	V
		to $-V_s$	0.8	1	1.4	V
t_d	Delay Time		10			μs

QUIESCENT CURRENT CONTROL

Symbol	Parameter	Test Conditions	Min.	Typ.	Max.	Unit
	Capacitor Current	Charge	30	60		μA
		Discharge	250	500		μA
	Comparator Reference	to $+V_s$	10	20	25	mV
		to $-V_s$		10		mV

TDA7250

Figure 1 : Application Circuit with Power Darlingtons.

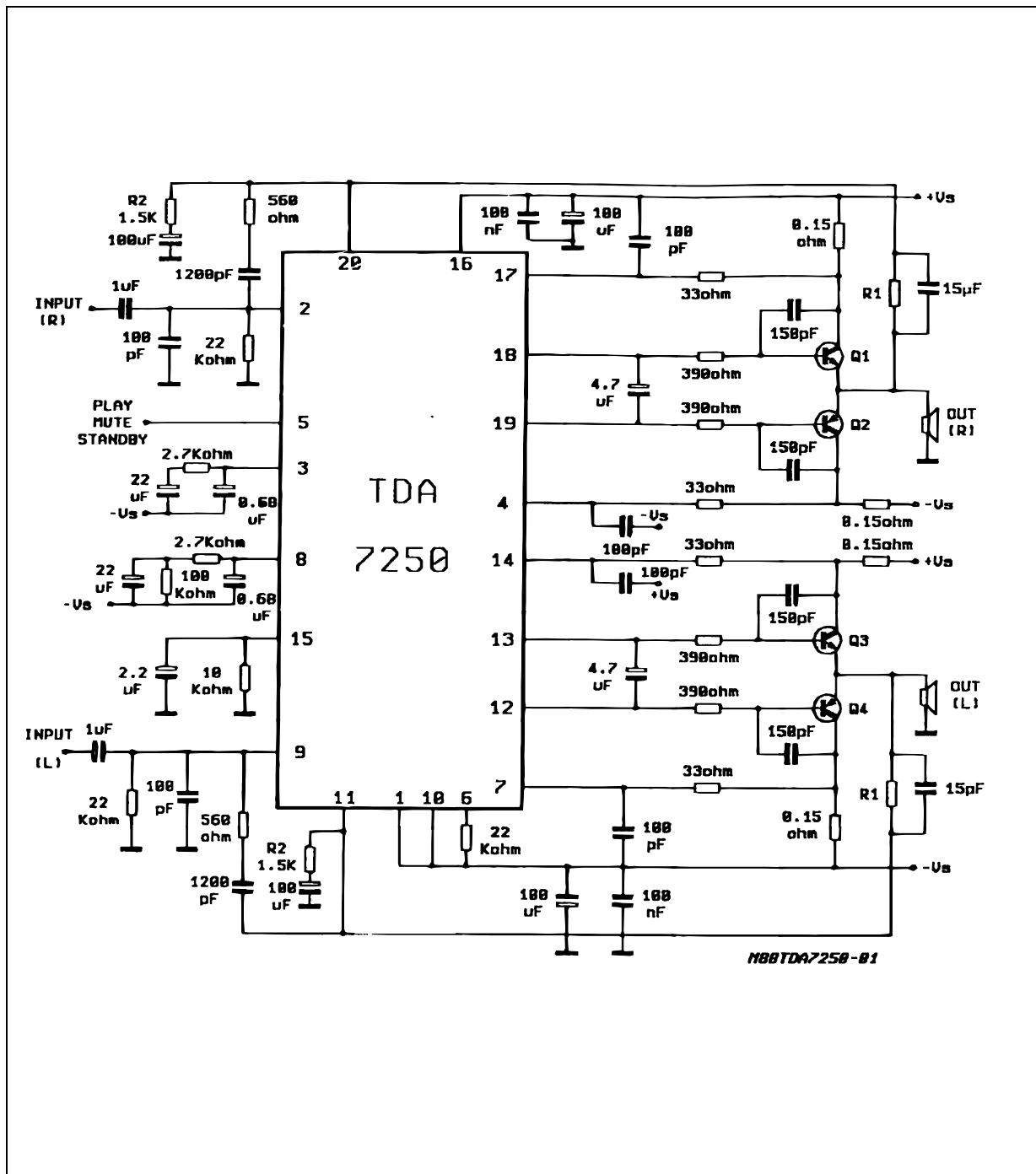

Note : Q1/Q2 = Q3/Q4 = TIP 142/TIP147
 $GV = 1 + R1/R2$

Figure 2 : Output Power vs. Supply Voltage.

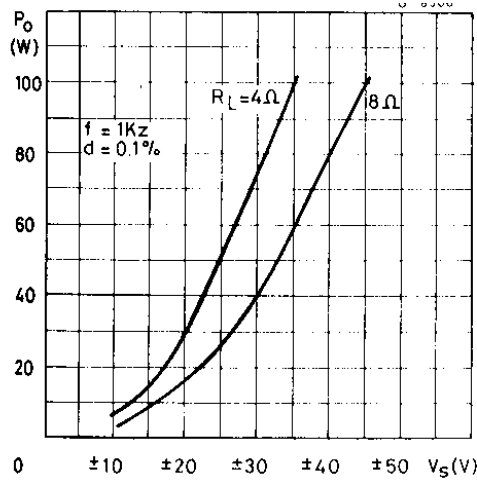

Figure 4 : Channel Separation.

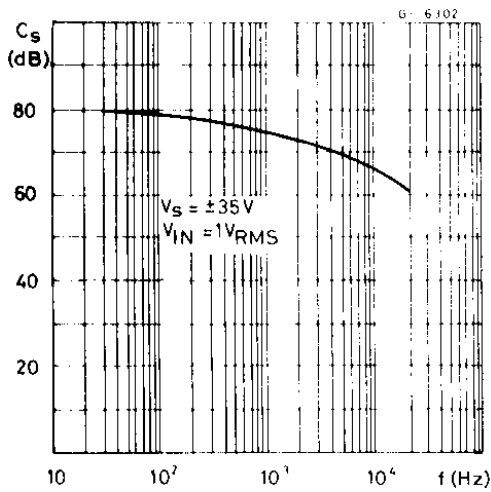

Figure 6 : Quiescent Current vs. Supply Voltage.

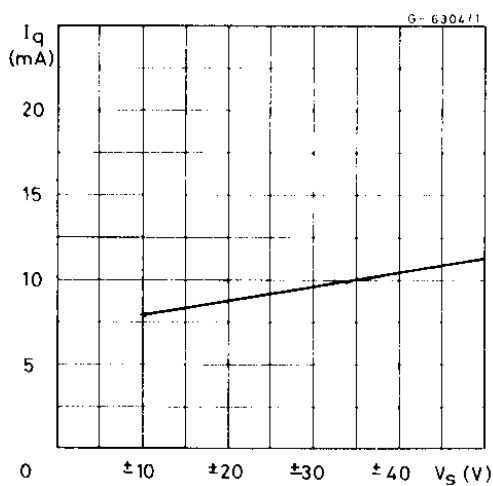

Figure 3 : Distortion vs. Output Power (*).

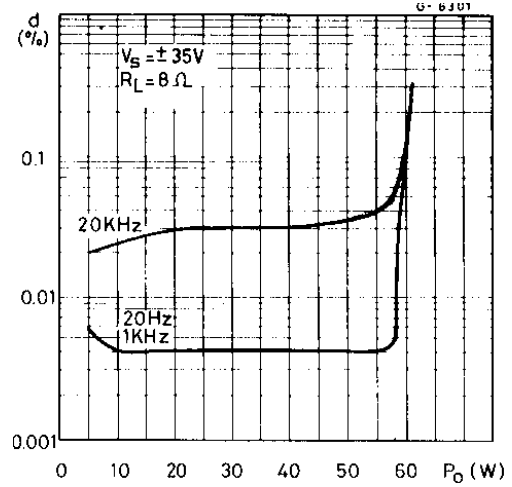

Figure 5 : Supply Voltage Rejection vs. Frequency.

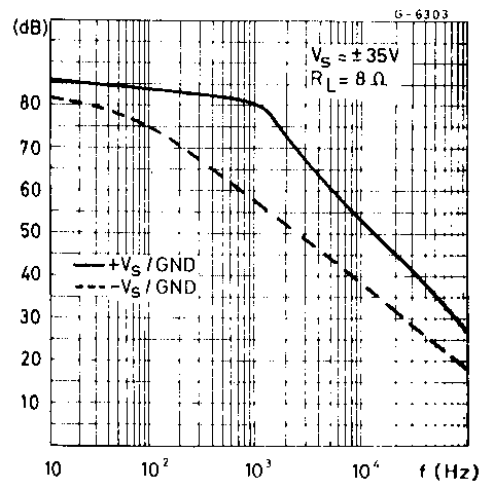

Figure 7 : Quiescent Current vs. Tamb.

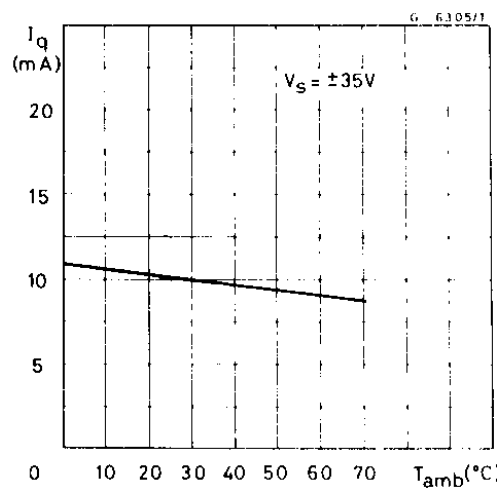

Figure 8 : Total Dissipated Power vs. Output Power (*).

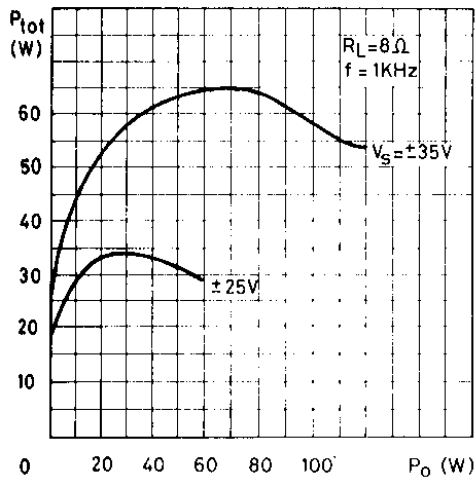

Figure 9 : Efficiency vs. Output Power (*).

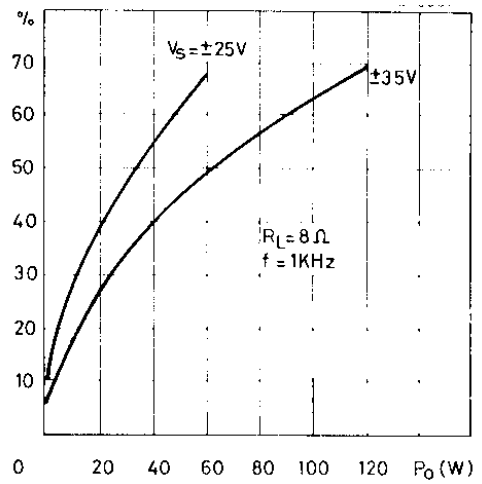
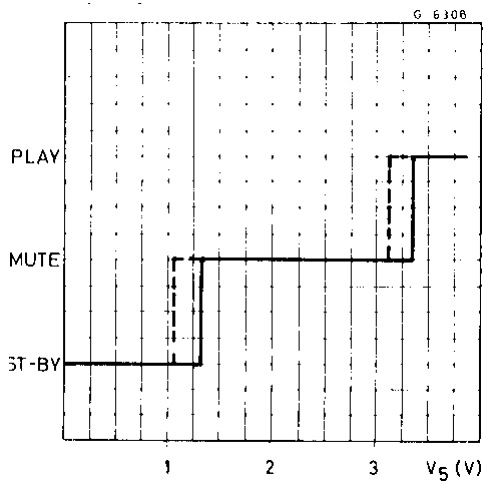

Figure 10 : Play-mute Standby Operation.



(*) Complete circuit

Figure 11 : Application Circuit Using Power Transistors.

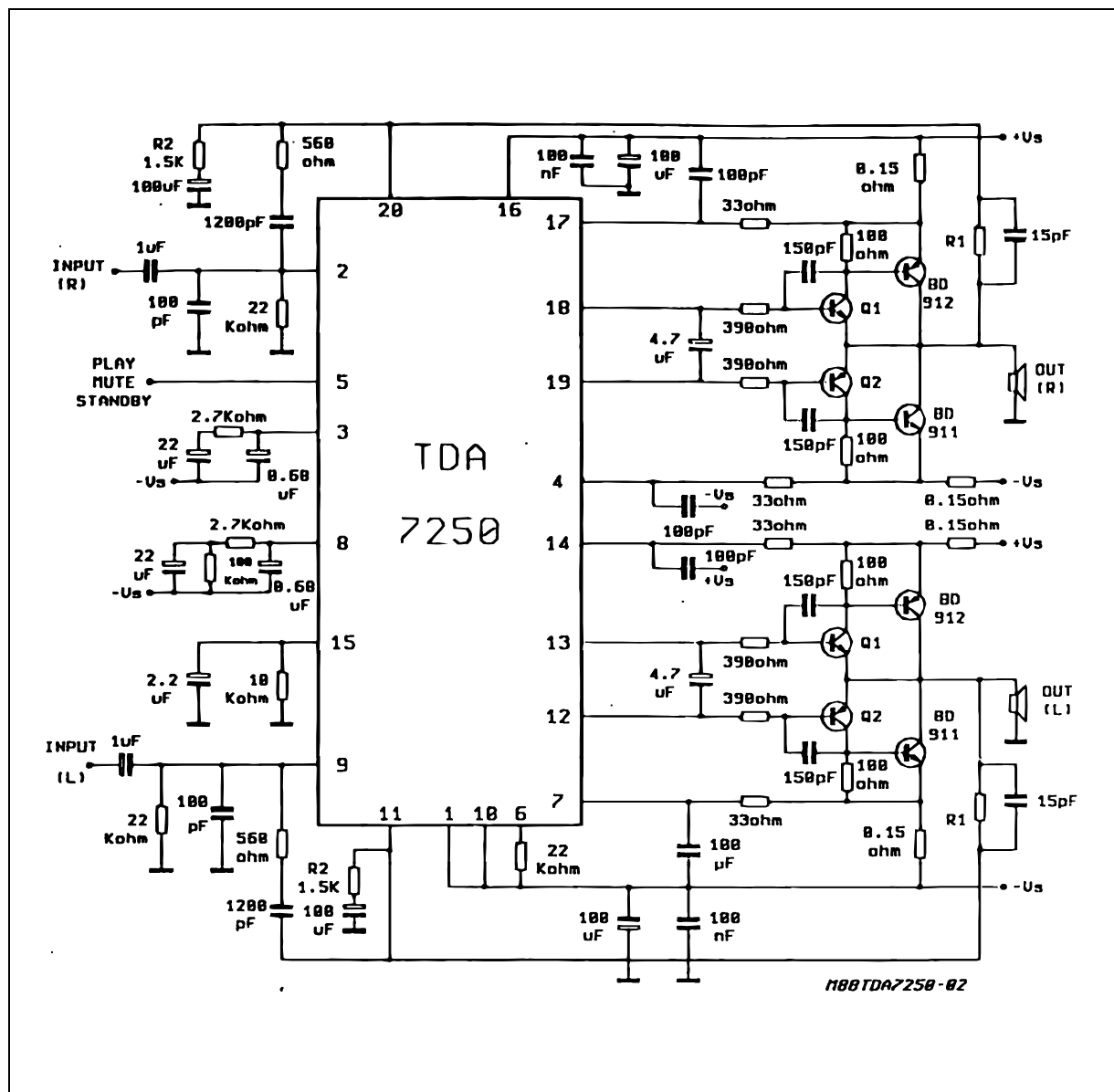

Figure 12 : Suggested Transistor Types for Various Loads and Powers.

$R_L = 8 \Omega$

15W	+30W	+50W	+70W
BDX 53/54A	BDX 53/54B	BDW 93/94B	TIP 142/147

$T_L = 4 \Omega$

30W	+50W	+90W	+130W
BDW 93/94A	BDW 93/94B	BDV 64/65B	MJ 11013/11014

DIP20 PACKAGE MECHANICAL DATA

DIM.	mm			inch		
	MIN.	TYP.	MAX.	MIN.	TYP.	MAX.
a1	0.51			0.020		
B	0.85		1.40	0.033		0.055
b		0.50			0.020	
b1	0.38		0.50	0.015		0.020
D			24.80			0.976
E		8.80			0.346	
e		2.54			0.100	
e3		22.86			0.900	
F			7.10			0.280
l			5.10			0.201
L		3.30			0.130	
Z			1.27			0.050

