

# DATA SHEET

**TDA2615**

**2 × 6 W hi-fi audio power amplifier**

Product specification  
Supersedes data of July 1994  
File under Integrated Circuits, IC01

1995 May 08

**Philips Semiconductors**



**PHILIPS**

**2 × 6 W hi-fi audio power amplifier****TDA2615****FEATURES**

- Requires very few external components
- No switch-on/switch-off clicks
- Input mute during switch-on and switch-off
- Low offset voltage between output and ground
- Excellent gain balance of both amplifiers
- Hi-fi in accordance with "IEC 268" and "DIN 45500"
- Short-circuit proof and thermal protected
- Mute possibility.

**GENERAL DESCRIPTION**

The TDA2615 is a dual power amplifier in a 9-lead plastic single-in-line (SIL9MPF) medium power package. It has been especially designed for mains fed applications, such as stereo radio and stereo TV.

**QUICK REFERENCE DATA**

Stereo application.

SYMBOL	PARAMETER	CONDITIONS	MIN.	TYP.	MAX.	UNIT
$\pm V_P$	supply voltage range		7.5	–	21	V
$P_O$	output power	$V_S = \pm 12\text{ V}$ ; THD = 0.5%	–	6	–	W
$G_v$	internal voltage gain		–	30	–	dB
$ G_v $	channel unbalance		–	0.2	–	dB
$\alpha$	channel separation		–	70	–	dB
SVRR	supply voltage ripple rejection		–	60	–	dB
$V_{no}$	noise output voltage		–	70	–	$\mu\text{V}$

**ORDERING INFORMATION**

TYPE NUMBER	PACKAGE		
	NAME	DESCRIPTION	VERSION
TDA2615	SIL9MPF	plastic single in-line medium power package with fin; 9 leads	SOT110-1

2 × 6 W hi-fi audio power amplifier

TDA2615

BLOCK DIAGRAM

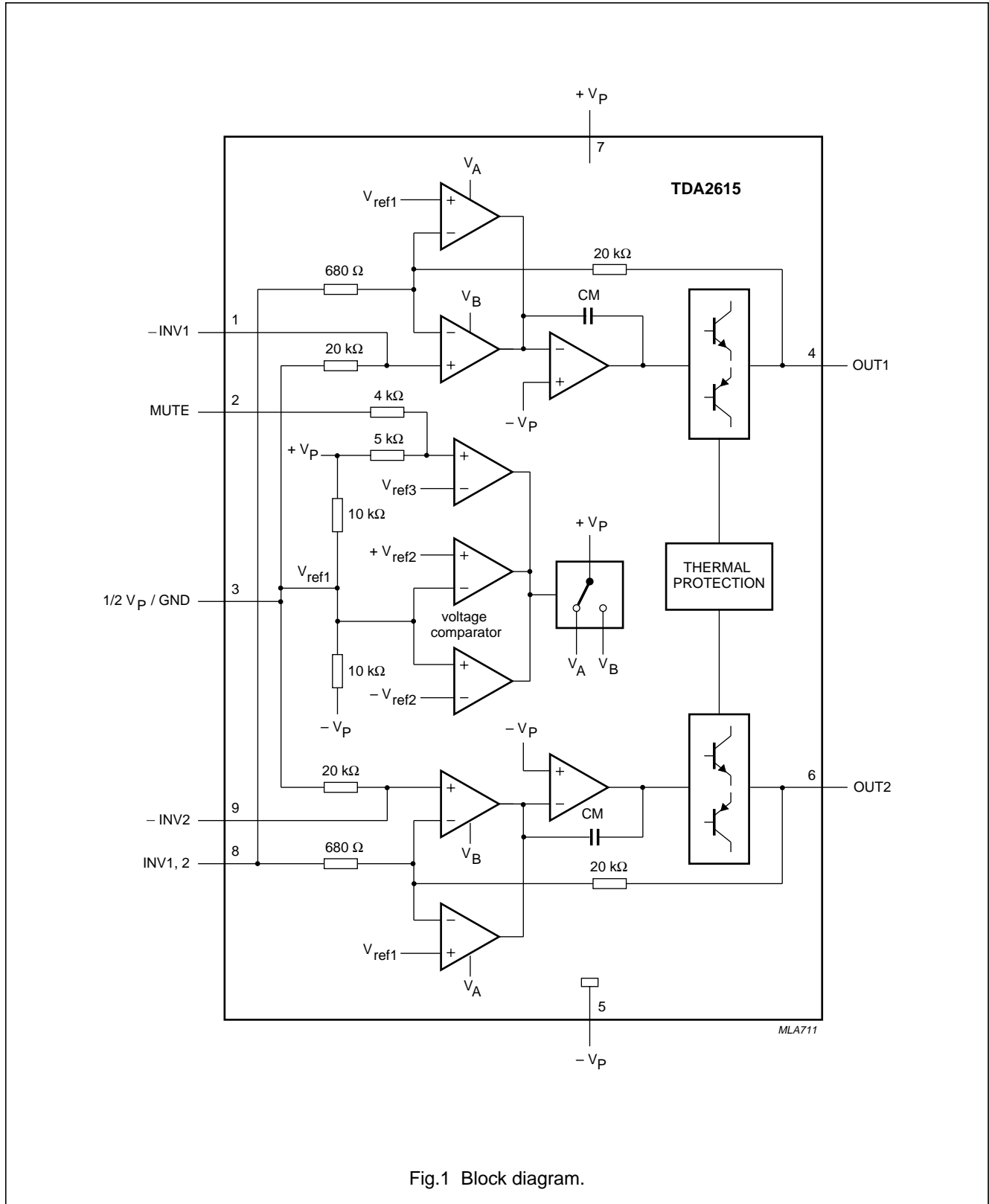

Fig.1 Block diagram.

2 × 6 W hi-fi audio power amplifier

TDA2615

**PINNING**

SYMBOL	PIN	DESCRIPTION
-INV1	1	non-inverting input 1
MUTE	2	mute input
1/2 V <sub>P</sub> /GND	3	1/2 supply voltage or ground
OUT1	4	output 1
-V <sub>P</sub>	5	supply voltage (negative)
OUT2	6	output 2
+V <sub>P</sub>	7	supply voltage (positive)
INV1, 2	8	inverting input 1 and 2
-INV2	9	non-inverting input 2

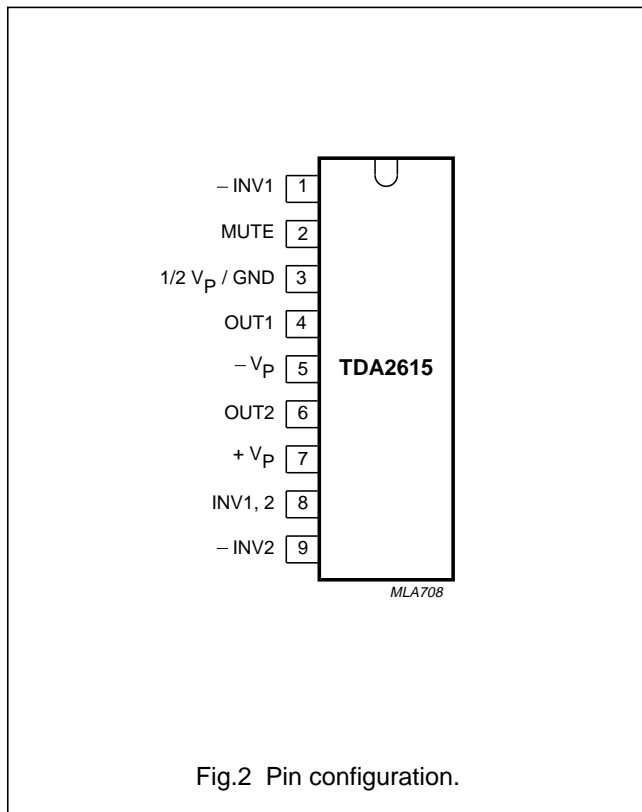

**FUNCTIONAL DESCRIPTION**

The TDA2615 is a hi-fi stereo amplifier designed for mains fed applications, such as stereo radio and stereo TV. The circuit is optimally designed for symmetrical power supplies, but is also well-suited to asymmetrical power supply systems.

An output power of 2 × 6 W (THD = 0.5%) can be delivered into an 8 Ω load with a symmetrical power supply of ±12 V. The gain is internally fixed at 30 dB, thus offering a low gain spread and a very good gain balance between the two amplifiers (0.2 dB).

A special feature is the input mute circuit. This circuit disconnects the non-inverting inputs when the supply voltage drops below ±6 V, while the amplifier still retains its DC operating adjustment. The circuit features suppression of unwanted signals at the inputs, during switch-on and switch-off.

The mute circuit can also be activated via pin 2. When a current of 300 μA is present at pin 2, the circuit is in the mute condition.

The device is provided with two thermal protection circuits. One circuit measures the average temperature of the crystal and the other measures the momentary temperature of the power transistors. These control circuits attack at temperatures in excess of +150 °C, so a crystal operating temperature of max. +150 °C can be used without extra distortion.

With the derating value of 6 K/W, the heatsink can be calculated as follows:

at R<sub>L</sub> = 8 Ω and V<sub>S</sub> = ±12 V, the measured maximum dissipation is 7.8 W.

With a maximum ambient temperature of +60 °C, the thermal resistance of the heatsink is:

$$R_{th} = \frac{150 - 60}{7.8} - 6 = 5.5 \text{ K/W}$$

The metal tab has the same potential as pin 5.

2 × 6 W hi-fi audio power amplifier

TDA2615

**LIMITING VALUES**

In accordance with the Absolute maximum System (IEC 134).

SYMBOL	PARAMETER	CONDITIONS	MIN.	MAX.	UNIT
$\pm V_P$	supply voltage		–	21	V
$I_{OSM}$	non-repetitive peak output current		–	4	A
$P_{tot}$	total power dissipation	see Fig.3	–	15	W
$T_{stg}$	storage temperature range		–55	+150	°C
$T_{xtal}$	crystal temperature		–	+150	°C
$T_{amb}$	ambient operating temperature range		–25	+150	°C
$t_{sc}$	short-circuit time	short-circuit to ground; note 1	–	1	h

**Note**

- For asymmetrical power supplies (with the load short-circuited), the maximum unloaded supply voltage is limited to  $V_P = 28\text{ V}$  and with an internal supply resistance of  $R_S \geq 4\ \Omega$ , the maximum unloaded supply voltage is limited to 32 V **(with the load short-circuited)**. For symmetrical power supplies the circuit is short-circuit-proof up to  $V_P = 21\text{ V}$ .

**THERMAL CHARACTERISTICS**

SYMBOL	PARAMETER	VALUE	UNIT
$R_{th\ j-c}$	thermal resistance from junction to case	6	K/W

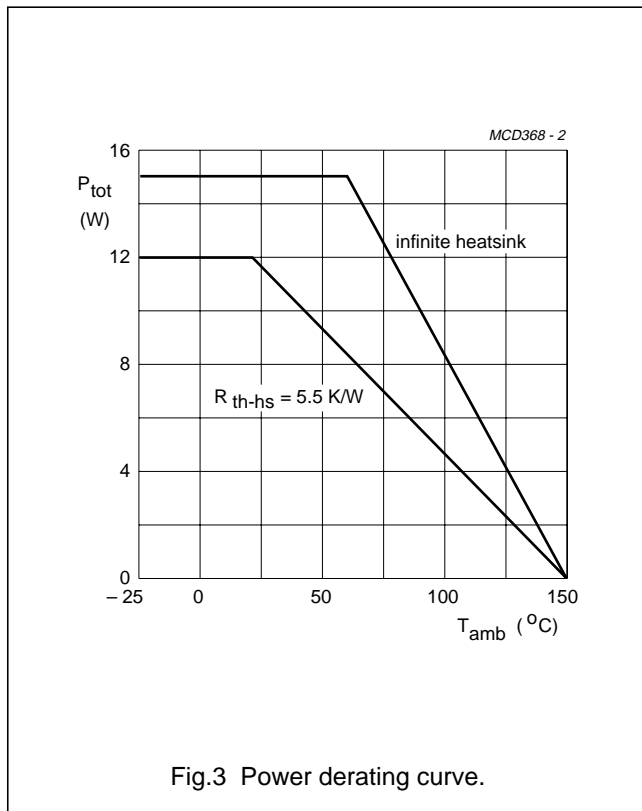

Fig.3 Power derating curve.

## 2 × 6 W hi-fi audio power amplifier

TDA2615

## CHARACTERISTICS

SYMBOL	PARAMETER	CONDITIONS	MIN.	TYP.	MAX.	UNIT
<b>Supply</b>						
$\pm V_P$	supply voltage range		–	12	21	V
$I_{ORM}$	repetitive peak output current		2.2	–	–	A
<b>Operating position; note 1</b>						
$\pm V_P$	supply voltage range		7.5	12	21	V
$I_{q(tot)}$	total quiescent current	$R_L = \infty$	18	40	70	mA
$P_O$	output power	THD = 0.5%	5	6	–	W
		THD = 10%	6.5	8	–	W
THD	total harmonic distortion	$P_O = 4\text{ W}$	–	0.15	0.2	%
B	power bandwidth	THD = 0.5%; note 2	–	20 to 20000	–	Hz
$G_V$	voltage gain		29	30	31	dB
$ G_V $	gain unbalance		–	0.2	1	dB
$V_{no}$	noise output voltage	note 3	–	70	140	$\mu\text{V}$
$ Z_i $	input impedance		14	20	26	$\text{k}\Omega$
SVRR	supply voltage ripple rejection	note 4	40	60	–	dB
$\alpha_{cs}$	channel separation	$R_S = 0$	46	70	–	dB
$I_{bias}$	input bias current		–	0.3	–	$\mu\text{A}$
$ \Delta V_{GND} $	DC output offset voltage		–	30	200	mV
$ \Delta V_{4-6} $	DC output offset voltage	between two channels	–	4	150	mV
<b>MUTE POSITION (AT <math>I_{MUTE} \geq 300\ \mu\text{A}</math>)</b>						
$V_O$	output voltage	$V_I = 600\text{ mV}$	–	0.3	1.0	mV
$Z_{2-7}$	mute input impedance		–	9	–	$\text{k}\Omega$
$I_{q(tot)}$	total quiescent current	$R_L = \infty$	18	40	70	mA
$V_{no}$	noise output voltage	note 3	–	70	140	$\mu\text{V}$
SVRR	supply voltage ripple rejection	note 4	40	55	–	dB
$ \Delta V_{GND} $	DC output offset voltage		–	40	200	mV
$ \Delta V_{off} $	offset voltage with respect to operating position		–	4	150	mV
$I_2$	current if pin 2 is connected to pin 5		–	–	6	mA
<b>Mute position; note 5</b>						
$\pm V_P$	supply voltage range		2	–	5.8	V
$I_P$	total quiescent current	$R_L = \infty$	9	30	40	mA
$V_O$	output voltage	$V_I = 600\text{ mV}$	–	0.3	1.0	mV
$V_{no}$	noise output voltage	note 3	–	70	140	$\mu\text{V}$
SVRR	supply voltage ripple rejection	note 4	40	55	–	dB
$ \Delta V_{GND} $	DC output offset voltage		–	40	200	mV

## 2 × 6 W hi-fi audio power amplifier

## TDA2615

SYMBOL	PARAMETER	CONDITIONS	MIN.	TYP.	MAX.	UNIT
<b>Operating position; note 6</b>						
$I_{q(\text{tot})}$	total quiescent current		18	40	70	mA
$P_O$	output power	THD = 0.5%	5	6	–	W
		THD = 10%	6.5	8	–	W
THD	total harmonic distortion	$P_O = 4 \text{ W}$	–	0.13	0.2	%
B	power bandwidth	THD = 0.5%; note 1	–	40 to 20000	–	Hz
$G_V$	voltage gain		29	30	31	dB
$ G_V $	gain unbalance		–	0.2	1	dB
$V_{no}$	noise output voltage	note 3	–	70	140	$\mu\text{V}$
$ Z_i $	input impedance		14	20	26	$\text{k}\Omega$
SVRR	supply voltage ripple rejection		35	44	–	dB
$\alpha_{cs}$	channel separation		–	45	–	dB
<b>MUTE POSITION (<math>I_{\text{MUTE}} \geq 300 \mu\text{A}</math>)</b>						
$V_O$	output voltage	$V_i = 600 \text{ mV}$	–	0.3	1.0	mV
$Z_{2-7}$	mute input impedance	note 7	6.7	9	11.3	$\text{k}\Omega$
$I_{q(\text{tot})}$	total quiescent current		18	40	70	mA
$V_{no}$	noise output voltage	note 3	–	70	140	$\mu\text{V}$
SVRR	supply voltage ripple rejection	note 4	35	44	–	dB
$ \Delta V_{\text{off}} $	offset voltage with respect to operating position		–	4	150	mV
$I_2$	current if pin 2 is connected to pin 5		–	–	6	mA

**Notes**

- $V_P = \pm 12 \text{ V}$ ;  $R_L = 8 \Omega$ ;  $T_{\text{amb}} = 25 \text{ }^\circ\text{C}$ ;  $f_i = 1 \text{ kHz}$ ; symmetrical power supply  $I_{\text{MUTE}} = < 30 \mu\text{A}$  (see Fig.4).
- The power bandwidth is measured at a maximum output power ( $P_{O\text{max}}$ ) of  $-3 \text{ dB}$ .
- The noise output voltage (RMS value) is measured at  $R_S = 2 \text{ k}\Omega$ , unweighted (20 Hz to 20 kHz).
- The ripple rejection is measured at  $R_S = 0$  and  $f_i = 100 \text{ Hz}$  to 20 kHz. The ripple voltage (200 mV) is applied in phase to the positive and the negative supply rails. With asymmetrical power supplies, the ripple rejection is measured at  $f_i = 1 \text{ kHz}$ .
- $\pm V_P = 4 \text{ V}$ ;  $R_L = 8 \Omega$ ;  $T_{\text{amb}} = 25 \text{ }^\circ\text{C}$ ;  $f_i = 1 \text{ kHz}$ ; symmetrical power supply (see Fig.4).
- $V_P = 24 \text{ V}$ ;  $R_L = 8 \Omega$ ;  $T_{\text{amb}} = 25 \text{ }^\circ\text{C}$ ;  $f_i = 1 \text{ kHz}$ ; asymmetrical power supply  $I_{\text{MUTE}} < 30 \mu\text{A}$  (see Fig.5).
- The internal network at pin 2 is a resistor divider of typical 4 k $\Omega$  and 5 k $\Omega$  to the positive supply rail. At the connection of the 4 k $\Omega$  and 5 k $\Omega$  resistor a zener diode of typical 6.6 V is also connected to the positive supply rail. The spread of the zener voltage is 6.1 to 7.1 V.

2 × 6 W hi-fi audio power amplifier

TDA2615

TEST AND APPLICATION INFORMATION

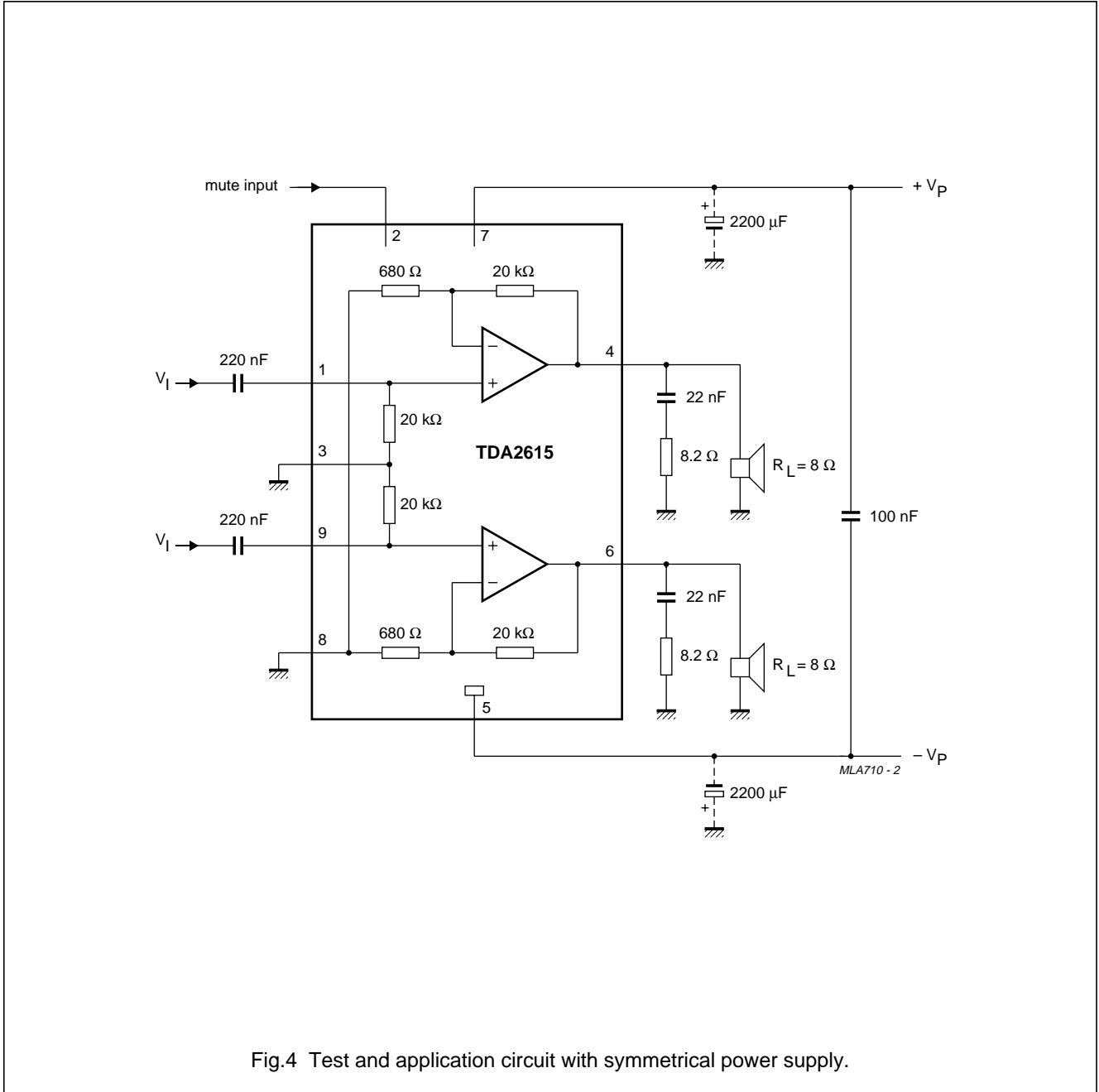

Fig.4 Test and application circuit with symmetrical power supply.

2 × 6 W hi-fi audio power amplifier

TDA2615

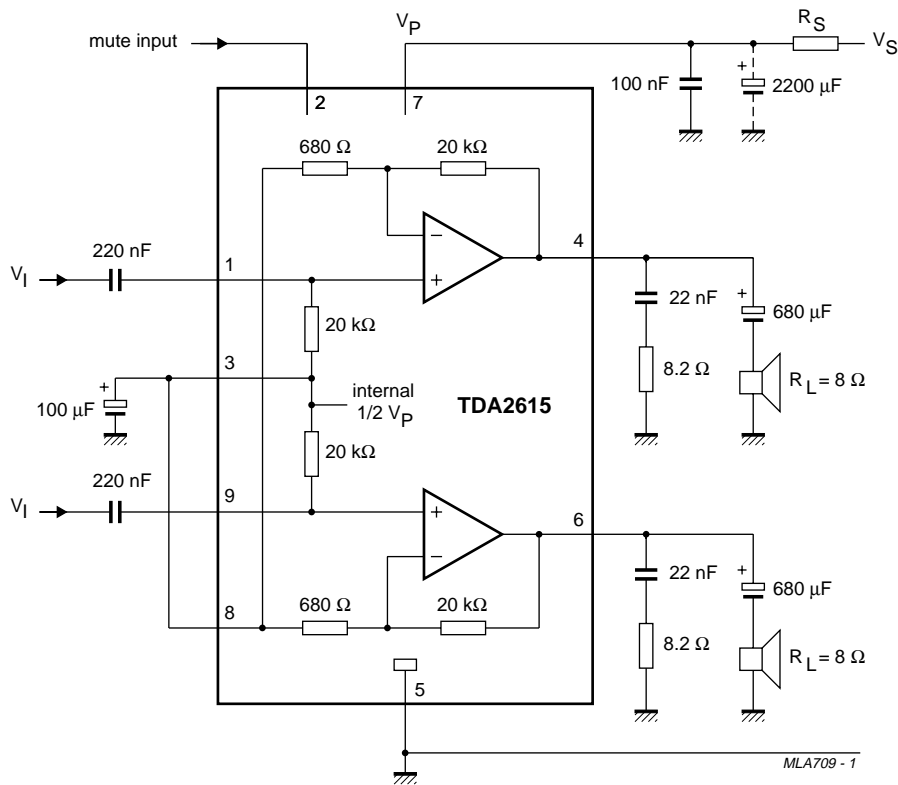

Fig.5 Test and application circuit with asymmetrical power supply.



## 2 × 6 W hi-fi audio power amplifier

TDA2615

### SOLDERING

#### Plastic single in-line packages

BY DIP OR WAVE

The maximum permissible temperature of the solder is 260 °C; this temperature must not be in contact with the joint for more than 5 s. The total contact time of successive solder waves must not exceed 5 s.

The device may be mounted up to the seating plane, but the temperature of the plastic body must not exceed the specified storage maximum. If the printed-circuit board has

been pre-heated, forced cooling may be necessary immediately after soldering to keep the temperature within the permissible limit.

#### REPAIRING SOLDERED JOINTS

Apply the soldering iron below the seating plane (or not more than 2 mm above it). If its temperature is below 300 °C, it must not be in contact for more than 10 s; if between 300 and 400 °C, for not more than 5 s.

### DEFINITIONS

<b>Data sheet status</b>	
Objective specification	This data sheet contains target or goal specifications for product development.
Preliminary specification	This data sheet contains preliminary data; supplementary data may be published later.
Product specification	This data sheet contains final product specifications.
<b>Limiting values</b>	
Limiting values given are in accordance with the Absolute Maximum Rating System (IEC 134). Stress above one or more of the limiting values may cause permanent damage to the device. These are stress ratings only and operation of the device at these or at any other conditions above those given in the Characteristics sections of the specification is not implied. Exposure to limiting values for extended periods may affect device reliability.	
<b>Application information</b>	
Where application information is given, it is advisory and does not form part of the specification.	

### LIFE SUPPORT APPLICATIONS

These products are not designed for use in life support appliances, devices, or systems where malfunction of these products can reasonably be expected to result in personal injury. Philips customers using or selling these products for use in such applications do so at their own risk and agree to fully indemnify Philips for any damages resulting from such improper use or sale.