

TEMPERATURE CONTROLLER TC3YF SERIES

M A N U A L



Thank you very much for selecting Autonics products.
For your safety, please read the following before using.

Caution for your safety

- Please keep these instructions and review them before using this unit.
- Please observe the cautions that follow:
 - Warning** Serious injury may result if instructions are not followed.
 - Caution** Product may be damaged, or injury may result if instructions are not followed.
- The following is an explanation of the symbols used in the operation manual.
 - Caution: injury or danger may occur under special conditions.

Warning

- In case of using this unit with machinery (Nuclear power control, medical equipment, vehicle, train, airplane, combustion apparatus, entertainment or special device etc.), it requires installing fail-safe device, or contact us for information on type required. It may result in serious damage, fire or human injury.
- It must be mounted on Panel.
- Do not connect terminals when it is power on. It may give an electric shock.
- Before connecting power, check the terminal number. It may cause a fire.
- Do not disassemble and modify this unit, when it requires. If needs, please contact us. It may give an electric shock and cause a fire.

Caution

- This unit shall not be used outdoors. It might shorten the life cycle of the product or give an electric shock.
- For wire connection, AWG No. 12-28 should be used and screw bolt on terminal block with 0.3N · m to 0.4N · m strength. It may result in malfunction or fire due to contact failure.
- Please observe specification rating. It might shorten the life cycle of the product and cause a fire.
- Do not use the load beyond rated switching capacity of relay contact. It may cause insulation failure, contact melt, contact failure, relay broken, fire etc.
- In cleaning the unit, do not use water or an oil-based detergent. It might cause an electric shock or fire that will result in damage to the product.
- Do not use this unit at place where there are flammable or explosive gas, humidity, direct ray the sun, radiant heat, vibration, impact etc. It may cause explosion.
- Do not inflow dust or wire drops into inside of this unit. It may cause a fire or mechanical trouble.
- Before connecting wires, check the terminal polarity. It may cause a fire or explosion.

Front panel identification

1 DEF (Defrost output lamp) : Light on when defrost output is ON
 2 FAN (Evaporation-fan output lamp) : Light on when evaporation-fan is ON
 3 COMP (Compressor output lamp) : Light on when compressor is ON
 4 MD (Mode key) : For entering, changing, shifting parameters
 5 ▲ (Setting key/Up/Down) : Up/Down the data for setting parameters
 6 - : Displaying minus
 7 FND (Display measuring value) : Display a current value on operation mode. Display a parameter and a set value when setting parameter
 8 (Display a decimal point) : Display a decimal point for the time unit 'min'
 9 (Display a decimal point) : Display a decimal point for the temperature unit '°C'
 10 ▲, ▼ (Variation indication part) : SV is standard, PV (Present temperature) - ▲ (Red) / ■ (Green)
 11 °C, °F (Temperature unit indication part) : Indicate temperature unit for indicating temperature
 12 When delay time is applied, the output lamp of defrost output, evaporation-fan and compressor is ON simultaneously after the lamp flickers every one second.

Dimensions

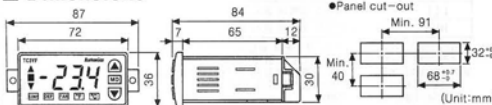

Connections

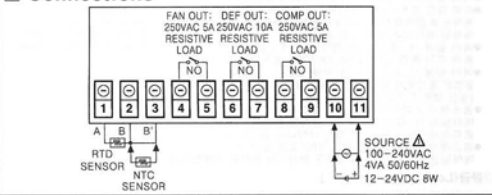

Functions

- Adjustable Hysteresis [HYS]**
 - This product controls compressor output by ON/OFF control type.
 - Frequent ON/OFF output causes noise and chattering. Proper interval on ON/OFF control prevents it and a malfunction on contact and compressor.
 - Ex) Setting value (Sv): -20°C, Hysteresis (HYS): 1
 - When current temperature is -19°C, compressor outputs ON.
 - When current temperature is -21°C, compressor outputs OFF.
 - ON/OFF control is also called 2-position control because of OFF output for low temperature and ON output for high temperature with a target value.
- Input correction [Inb]**
 - This model corrects the error, which is occurred by inputted signal.
 - When measuring a temperature, it corrects the error occurred by disturbance or extended wire.
 - The corrected temperature and set value is compared for the operation.
 - Ex) Current temperature: -18°C, Display value: -20°C
 - When setting Inb as 2, display value will be -18°C.
- Defrost function**
 - When compressor drives for long time, heat efficiency is lowered because evaporator and refrigerator are frozen. In this case, it is called defrost function for removing ice and frost.
 - Heating defrost method
 - After mounting heater around evaporator, operate the heater with deforest period and deforest time setting of controller and remove frost.
 - Manual defrost method
 - It operates defrosting for setting defrost time when press [▲] for 3sec during driving the compressor. When pressing [▼] for 3sec, defrost function is stopped, defrost output is turned to OFF and setting defrost period is restarted from OFF.
 - After operating defrost for setting defrost time, setting defrost period is restarted.
 - In case defrost period is '00', manual defrosting is operated only.
- Relay output**
 - Relay output is operating for ON/OFF output by using relay contact. It repeats ON/OFF the load in order to heating or cooling operation continuously. In this case, drive magnetic SV or power relay (big capacity) can be used by using relay contact.
 - For using relay contact, do not exceed relay capacity.
 - Otherwise a relay contact can be damaged and it can cause fire.
 - When using relay contact to control main relay or magnetic switch, please use surge absorber in order not to inflow of counter electromagnetic force, caused from the coil of relay and magnet, into the inner body.
 - Life cycle of relay (electrical/mechanical) is indicated in "Specifications".
 - Please design the system after checking the life cycle of relay.
 - The above specifications are subject to change without notice.

Ordering information

TC	3	Y	F	-	□	R
① Item	TC	Temperature Controller				
② Digit	3	999 (Digit)				
③ Size	Y	DIN W72×H36mm				
④ Refrigeration control	F	Freezing				
⑤ Sub output	2	Compressor+Defrost output				
⑥ Power supply	1	12-24VDC				
⑦ Output	R	Relay output				

Specifications

Model (★1)	TC3YF-11R	TC3YF-14R	TC3YF-21R	TC3YF-24R	TC3YF-31R	TC3YF-34R
Power supply	12-24VDC	100-240VAC 50/60Hz	12-24VDC	100-240VAC 50/60Hz	12-24VDC	100-240VAC 50/60Hz
Allowable voltage range	90 to 110% of rated voltage					
Power consumption	8W	4VA	8W	4VA	8W	4VA
Indication method	7Segment LED Display (Red)					
Display	NTC : -40.0-99.9°C (-40-212°F), RTD : -99.9-99.9°C (-148-212°F)					
Display method	[PV ±0.5% or 1°C Max.] rdg ±1digit (Room temperature: 23 ± 0.5°C)					
Sampling period	Min. 0.5sec					
Input sensor	NTC : Thermistor, RTD : DPT 100Ω (★2)					
Input of line resistance	Tolerance line resistance is max. 5Ω					
Control method	ON/OFF control/Adjustment sensitivity (HYS) variable (0.5-5.0°C, 2-50°F)					
Control output	Compressor (250VAC 5A 1a)	Compressor (250VAC 5A 1a) Defrost output (250VAC 10A 1a)	Compressor (250VAC 5A 1a) Defrost output (250VAC 10A 1a) Evaporation-fan output (250VAC 5A 1a)	Compressor (250VAC 5A 1a) Defrost output (250VAC 10A 1a) Evaporation-fan output (250VAC 5A 1a)	Compressor (250VAC 5A 1a) Defrost output (250VAC 10A 1a) Evaporation-fan output (250VAC 5A 1a)	Compressor (250VAC 5A 1a) Defrost output (250VAC 10A 1a) Evaporation-fan output (250VAC 5A 1a)
Insulation resistance	Min. 100MΩ (at 50VDC mega)					
Dielectric strength	2000VAC 60Hz for 1 minute (between external terminal and case)					
Noise strength	±500V R-phase and S-phase (pulse width 1μs) (12-24VDC) ±2kV R-phase and S-phase (pulse width 1μs) (100-240VAC)					
Memory retention	Approx. 10 years (When using non-volatile semiconductor memory type)					
Relay life cycle	COMP	Mechanical : Min. 20,000,000 times Electrical : Min. 50,000 times (250VAC 5A resistive load)	Mechanical : Min. 20,000,000 times Electrical : Min. 100,000 times (250VAC 10A resistive load)	Mechanical : Min. 20,000,000 times Electrical : Min. 100,000 times (250VAC 10A resistive load)	Mechanical : Min. 20,000,000 times Electrical : Min. 100,000 times (250VAC 5A resistive load)	Mechanical : Min. 20,000,000 times Electrical : Min. 100,000 times (250VAC 5A resistive load)
Vibration	0.75mm amplitude at frequency of 10 to 55Hz in each of X, Y, Z directions for 10 minutes 0.5mm amplitude at frequency of 10 to 55Hz in each of X, Y, Z directions for 10 minutes					
Ambient temperature	-10 ~ 50°C (at non-freezing status)					
Storage temperature	-20 ~ 60°C (at non-freezing status)					
Ambient humidity	35 ~ 85%RH					
Protection	IP65					
Approval	(*) CE, (*) VDE, (*) UL, (*) IEC					
Weight	Approx. 143g					

★1 Indication accuracy of sensor except for room temperature is ambient temperature range : (The bigger one between PV ±0.5% or 1°C) rdg ±1°C
 ★2 (★1) There is no relay point of contact where defrost lamp is lighted for 11R/14R.
 ★3 (★2) RTD is optional.
 ★4 (★3) No UL certificate is acquired for this model.

SV checking and setting

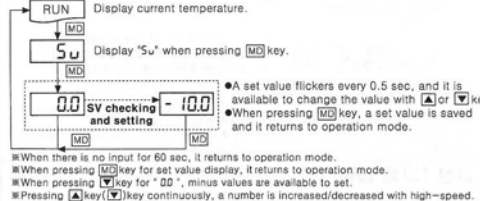

Flow chart for first setting group

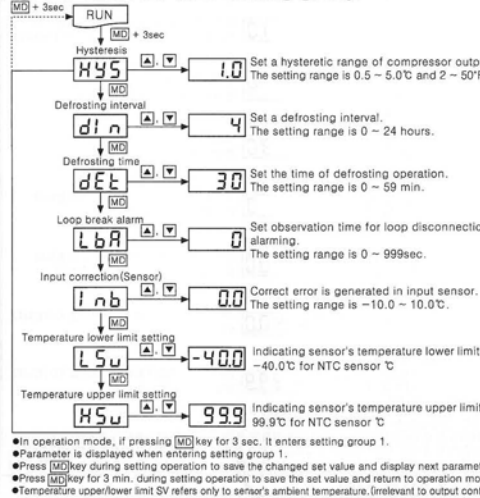

● In operation mode, if pressing [MD] key for 3 sec, it enters setting group 1.
 ● Parameter is displayed when entering setting group 1.
 ● Press [MD] key during setting operation to save the changed set value and display next parameter.
 ● Press [MD] key for 3 min. during setting operation to save the set value and return to operation mode.
 ● Temperature upper/lower limit SV refers only to sensor's ambient temperature. (irrelevant to output control)

Flow chart for second setting group

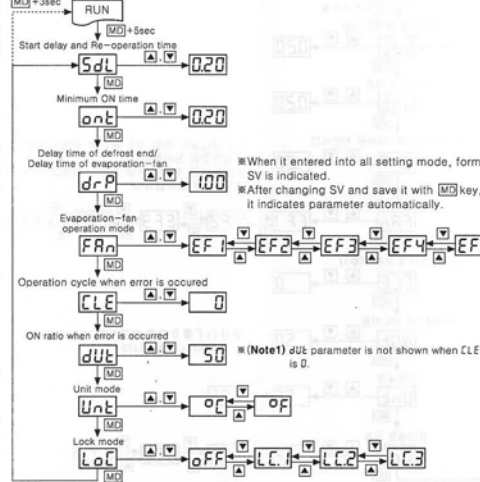

Input specification and range

Input sensor	Using range	°C	°F
RTD (DPT 100Ω)		-99.9 ~ 99.9	-148 ~ 212
Thermistor		-40.0 ~ 99.9	-40 ~ 212

★ A temperature sensor converts temperature into electric signal, and a temperature controller measures the temperature in order to do ON/OFF the control output.
 ★ The setting is available within using range, and set range is fixed with using range.

Operation

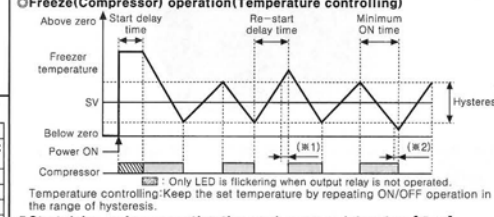

- Start delay and re-operation time and re-start delay time [SdL]**
 - Start delay (Setting range: 0m10s-9m59s)
When apply the power again on a compressor after power is failed, the compressor will be under overload. In this case, start delay function prevents curtailing of the life cycle of a compressor.
 - Re-start delay time (Setting range: 0m10s-9m59s)
It does not operate within re-start delay time after compressor OFF to prevent frequent ON/OFF.
 - (★1) For start delay time, compressor output is OFF even when PV (Process Value) is lower than SV (Set Value). It is turned to ON after re-start delay time.
 - The output lamp is ON simultaneously after the lamp flickers every one second during re-start delay time.
- Minimum ON time [onT]**
 - Set a minimum ON time to prevent frequent ON/OFF.
 - (★2) Compressor output is ON even when PV (Process Value) is lower than SV (Set Value). It is turned to ON after the minimum ON time.

Defrosting operation (Heating defrost method)

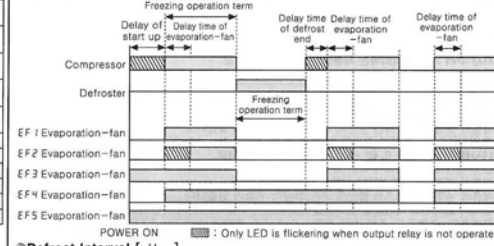

● Only LED is flickering when output relay is not operated.
 Temperature controlling: Keep the set temperature by repeating ON/OFF operation in the range of hysteresis.

Defrost interval [dIn]

Start defrosting for relevant interval. (Setting range: 0-24hour)
 Defroster (heater) is ON during/Defrost time. (Setting range: 0-59m)

Delay time of defrost end/Delay time of evaporation-fan operation [dEt]

- It is the time from drops are fallen down to the drops are drained. After drops are drained, compressor starts operating. (Setting range: 0m00s-5m59s)
- Delay time of evaporation-fan operation
To improve the efficiency of frosting, the time of evaporation-fan operation is delayed until evaporation plate is frozen after compressor operating. (Setting range: 0m00s-5m59s)
- The delay time of defrosting end and the delay time of evaporation-fan operation are used independently with one setting time (d-P).
- When the delay time of defrosting end is finished, defrosting is discontinued and defrosting interval is restarted.
- The output lamp is ON simultaneously after the lamp flickers every one second during delay time.

Evaporation-fan operation mode [FRn]

- Operation mode 1 [EF1] : Operate at the same time with compressor. OFF for defrost operation.
- Operation mode 2 [EF2] : Operate after the delay time of evaporation-fan operation. OFF for defrost operation.
- Operation mode 3 [EF3] : Keep operating even after compress OFF. OFF only for defrost operation.
- Operation mode 4 [EF4] : Operate after delay time of defrost end. The output will be OFF when compressor output and defrost output is OFF. (for controlling higher than zero point)
- Operation mode 5 [EF5] : Operate right after inputting power.

Error display

- Error mark and error content are flickering every 0.5 sec. when error is occurred.
 - Display Error
- | | |
|-----|---|
| oPn | Input sensor disconnected (Operate after connecting sensor) |
| LbR | Input sensor is normal or refrigerator temperature change is in 10°C or 2°F for observation time of loop disconnection. |
| LtL | Measured sensor input is lower than displayed range |
| HhH | Measured sensor input is higher than displayed range |
- For the Error (oPn, LtL, HhH), after solving the problems (Connecting sensor/Changing measured value within displayed range), it operates normally.
 For Error (LbA), if press both [▼] and [▲] key for 3 sec, after checking compressor, it operates normally. When LbA is 0, the function is OFF.

Compressor operation for error

- Controller does not operate normally in error.
- To protect the inside of compressor, compressor keeps repetitive operation until error is removed.
- The cycle of compressor operation in error [CLE]
- Compressor operates ON/OFF during set operation cycle.
- The ratio of compressor ON in error [dEt]
- During set operation cycle, compressor operates ON as much as set ratio.
- The operation cycle of compressor is "0". Compressor OFF
- When error is occurred, ON/OFF cycle is not operated and compressor operation is OFF. Compressor ON ratio (100% parameter is not displayed)
- The ratio of compressor ON is "100". Compressor is ON when error is occurred.

Lock function [Lc]

- Limit the change of SV and parameter
- oFF : Lock off Lc2 : Setting group 1, Setting group 2 Lock
 Lc1 : Setting group 2 Lock Lc3 : Setting group 1, Setting group 2, Set value Lock

Factory default

First setting group		Second setting group		Setting value (Sv)	
Mode	Setting value	Mode	Setting value	Mode	Setting value
HYS	1.0	Inb	0.0	Su	0.0
dIn	4	LSw	-40.0	onT	0.20
dEt	30	HSw	99.9	drP	1.00
LbR	0	NTC sensor input °C		FRn	0
		NTC sensor input °F		Lc1	oFF

Caution for using

- Installation environment
 - Altitude Max. 2000m.
 - Pollution Degree 2
 - Installation Category II.
 - Please use separated line from high voltage line or power line in order to avoid inductive noise.
 - Please install power switch or circuit-breaker in order to cut power supply off.
 - The switch or circuit-breaker should be installed near by users.
 - Do not use this product as Volt-meter or Amper-meter, this is a temperature controller.
 - In case of using RTD sensor, 3wire type must be used. If you need to extend the line, 3wires must be used with the same thickness as the line.
 - It might cause the deviation of temperature if the resistance of temperature is line is different.
 - In case of making power line and input signal line close, line filter for noise protection should be installed at power line and input signal line close, line filter for noise protection should be installed at power line and input signal line close, line filter should be shielded.
 - Keep away from the high frequency instruments. (High frequency welding machine & sewing machine, big capacitive SCR controller)
- It may cause malfunction if above instructions are not followed.

Major products

- PROXIMITY SENSOR ● PHOTOELECTRIC SENSOR
- AREA SENSOR ● FIBER OPTIC SENSOR
- ROOM/ROOM SIZE SENSOR ● PRESSURE SENSOR
- ROTARY ENCODER ● SENSOR CONTROLLER
- SWITCHING POWER SUPPLY ● TEMPERATURE CONTROLLER
- TEMPERATURE/HUMIDITY TRANSDUCER
- POWER CONTROLLER
- RECORDER ● TACH/METER/PULSE(RATE) METER
- PANEL METER ● INDICATOR
- SIGNAL CONVERTER ● COUNTER
- TIMER ● DISPLAY UNIT
- GRAPHIC LOGIC PANEL
- STEPPING MOTOR & DRIVER & MOTION CONTROLLER

Autonics Corporation
 http://www.autonics.com
 Satellite Partner For Factory Automation
 41-1, Yongsong-dong, Yongsong-gu, Gyeongsang-do 610-841, Korea
 Tel: 82-54-831-1111, Fax: 82-54-831-1199
 E-mail: autonics@autonics.com
 The product of a product improvement and development. Product/Service.com
 EP-KE-03-3170D