



SANYO Semiconductors

DATA SHEET

STK621-043A-E

Thick-Film Hybrid IC

**Air Conditioner Three-Phase
Compressor Motor Driver
IMST Inverter Power Hybrid IC**

Overview

The STK621-043A-E is a 3-phase inverter power hybrid IC integrating 3-phase inverter power output stages, pre-driver, and a full complement of protection circuits in one package

Applications

- Air conditioner three-phase compressor motor driver.

Features

- Built-in overcurrent protection (bus line) and pre-driver supply under voltage protection.
- Allows CMOS-level input of control signals without an insulating circuit.
- Use of an upper-side power supply bootstrap circuit (externally set) enables single power supply drive.
- Built-in circuit for preventing short circuits when both upper and lower inputs are ON at the same time. This prevents arm short circuits due to simultaneous upper and lower phase ON inputs. (A dead time is needed to prevent short circuits due to switching delay.)
- The level of the overcurrent protection current can be changed by using the external resistor R_{SD} inserted between the I_{SD} and V_{SS} terminals. (It is necessary to connect resistor R_{SD} to assure normal operation of overcurrent protection function. I_{SD} is 28A to 38A when R_{SD} is 0Ω .)
- The substrate temperature can be monitored through the use of an internal thermistor.
- Transfer full mold structure SIP. (Single Inline Package.)

■ Any and all SANYO Semiconductor Co.,Ltd. products described or contained herein are, with regard to "standard application", intended for the use as general electronics equipment (home appliances, AV equipment, communication device, office equipment, industrial equipment etc.). The products mentioned herein shall not be intended for use for any "special application" (medical equipment whose purpose is to sustain life, aerospace instrument, nuclear control device, burning appliances, transportation machine, traffic signal system, safety equipment etc.) that shall require extremely high level of reliability and can directly threaten human lives in case of failure or malfunction of the product or may cause harm to human bodies, nor shall they grant any guarantee thereof. If you should intend to use our products for applications outside the standard applications of our customer who is considering such use and/or outside the scope of our intended standard applications, please consult with us prior to the intended use. If there is no consultation or inquiry before the intended use, our customer shall be solely responsible for the use.

■ Specifications of any and all SANYO Semiconductor Co.,Ltd. products described or contained herein stipulate the performance, characteristics, and functions of the described products in the independent state, and are not guarantees of the performance, characteristics, and functions of the described products as mounted in the customer's products or equipment. To verify symptoms and states that cannot be evaluated in an independent device, the customer should always evaluate and test devices mounted in the customer's products or equipment.

STK621-043A-E

Specifications

Absolute maximum ratings at $T_c = 25^\circ\text{C}$

Parameter	Symbol	Conditions	Ratings	Unit
Supply voltage	V_{CC}	+ to - pins, surge < 500V *1	450	V
Collector-to-emitter voltage	V_{CE}	+ to U (V, W) or U (V, W) to -	600	V
Output current	I_O	+, -, U, V, W pin current	± 20	A
Output peak current	I_{op}	+, -, U, V, W pin current PW=100 μ s	± 40	A
Control supply voltage	$V_{D1, 2, 3, 4}$	VB1-U, VB2-V, VB3-W, $V_{DD}-V_{SS}$ *2	20	V
Input signal voltage	V_{IN}	HIN1, 2, 3, LIN1, 2, 3 pins	0 to 7	V
FAULT pin voltage	V_{FAULT}	FAULT pin	20	V
Maximum power dissipation	P_d	IGBT, per 1 channel	36	W
Junction temperature	T_j	IGBT, FRD junction temperature	150	$^\circ\text{C}$
Storage temperature	T_{stg}		-40 to +125	$^\circ\text{C}$
Operating substrate temperature	T_c	HIC case temperature	-20 to +100	$^\circ\text{C}$
Tightening torque	MT	A screw part *3	1.0	N•m
Insulation breakdown voltage	Vis	Sine wave 50Hz AC 1min	2000	VRMS

Unless otherwise specified, the voltage reference for - pins is the V_{SS} pin voltage.

*1 Surge voltage generated by switching operation due to the effects of wiring inductance between + and -.

*2 VD1 = voltage between VB1 and U; VD2 = voltage between VB2 and V; VD3 = voltage between VB3 and W; VD4 = voltage between V_{DD} and V_{SS}

*3 Heat sink plate-mounting flatness: 0.15mm or less

*4 Test conditions: AC 2500V for 1second

Electrical Characteristics at $T_c=25^\circ\text{C}$, $V_D=15\text{V}$

Parameters	Symbols	Conditions	min	typ	max	unit	Test circuit	
Power output block								
Collector-to-emitter cut-off current	I_{CE}	$V_{CE}=600\text{V}$			0.5	mA	Fig.1	
Collector-to-emitter saturation voltage	$V_{CE}(\text{SAT})$	$I_O=20\text{A}$	Upper side		2.0	2.6	V	Fig.2
			Lower side		2.6	3.2		
Diode forward voltage	V_F	$I_O=-20\text{A}$	Upper side		1.8	2.4	V	Fig.3
			Lower side		2.4	3.0		
Junction-to-substrate thermal resistance	$\theta_j-c(\text{T})$	IGBT		3.0		$^\circ\text{C/W}$		
	$\theta_j-c(\text{D})$	FWD		4.8				
Control (Pre-driver) block								
Control circuit current dissipation	I_D	$V_{D1, 2, 3}=15\text{V}$		0.07	0.4	mA	Fig.4	
		$V_{D4}=15\text{V}$		3.3	7			
ON input signal voltage	V_{IH}	Output ON			0.8	V		
OFF input signal voltage	V_{IL}	Output OFF	3.0			V		
Protection section								
Overcurrent protection current	I_{SD}	PW=100 μ s, $R_{SD}=0\Omega$	28		38	A	Fig.5	
Control supply under voltage protection	UVLO		10		12	V		
FAULT pin intake current	I_{OSD}	When FAULT operating (Low), $V_{FAULT}=1\text{V}$		0.5		mA		
FAULT clear delay time	FLTCLR	After the end of each protection operation	18		80	ms		
Resistance value for monitoring substrate temperature	R_t	Resistance between the FAULT and V_{SS} terminals	90	100	110	k Ω		
Switching time	TON	$I_O=20\text{A}$, Inductive load		0.7		μs	Fig.6	
	TOFF			1.4				
Electric current output signal level	I_{SO}	$I_O=20\text{A}$		0.48		V		

Unless otherwise specified, the voltage reference for - pins is the V_{SS} pin voltage.

STK621-043A-E

Notes

1. The ON input signal voltage prescribes the input signal voltage at which the output stage IGBT turns ON, and the OFF input signal voltage prescribes the input signal voltage at which the output stage IGBT turns OFF.
Apply a voltage between 0 and V_{IH} (max) when output is ON, and a voltage between V_{IL} (min) and V_{DD} when output is OFF.
2. When the internal protection circuit is activated, the FAULT signal turns on (when the FAULT terminal is low level, FAULT signal is ON state: output form is open DRAIN) but the FAULT signal is not latched.
After protection operation ends, the IC returns automatically within about 18ms to 80ms and establishes the state to start operation. So, after detecting the FAULT signal, set all input signals off (high) at once.
The operation of under-voltage protection of the control power supply (UVLO: having a hysteresis of about 0.3V) is as follows.
Upper arm → Outputs no FAULT signal, but turns off the corresponding gate signal. It returns to the regular operation after recovering the normal voltage, but the latch state continues while the input signal is on (low).
Lower arm → Outputs FAULT signal while turns the gate signal off. However, unlike the protection operation of upper arm, it returns automatically within about 18ms to 80ms and establishes the state to start operation after recovering the normal voltage. (The protection operation is not latched by the input signal.)
3. When assembling the hybrid IC on the heat sink, tightening torque range is 0.8N•m to 1.0N•m.
4. The control supply voltage-drop protection function protects the devices when the control supply voltage drops due to some abnormality during operation. Control supply voltage drop at the start of operation and other cases should be confirmed in the set-mounted condition.

Package Dimensions

unit:mm (typ)

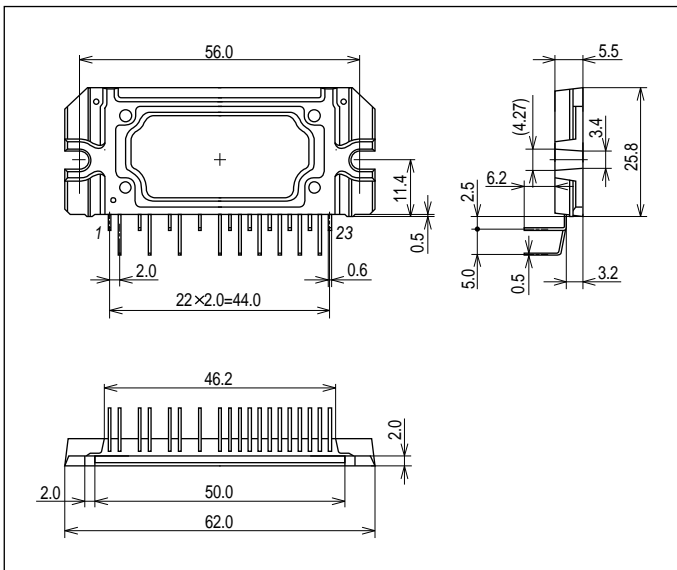

Circuit Block Diagram

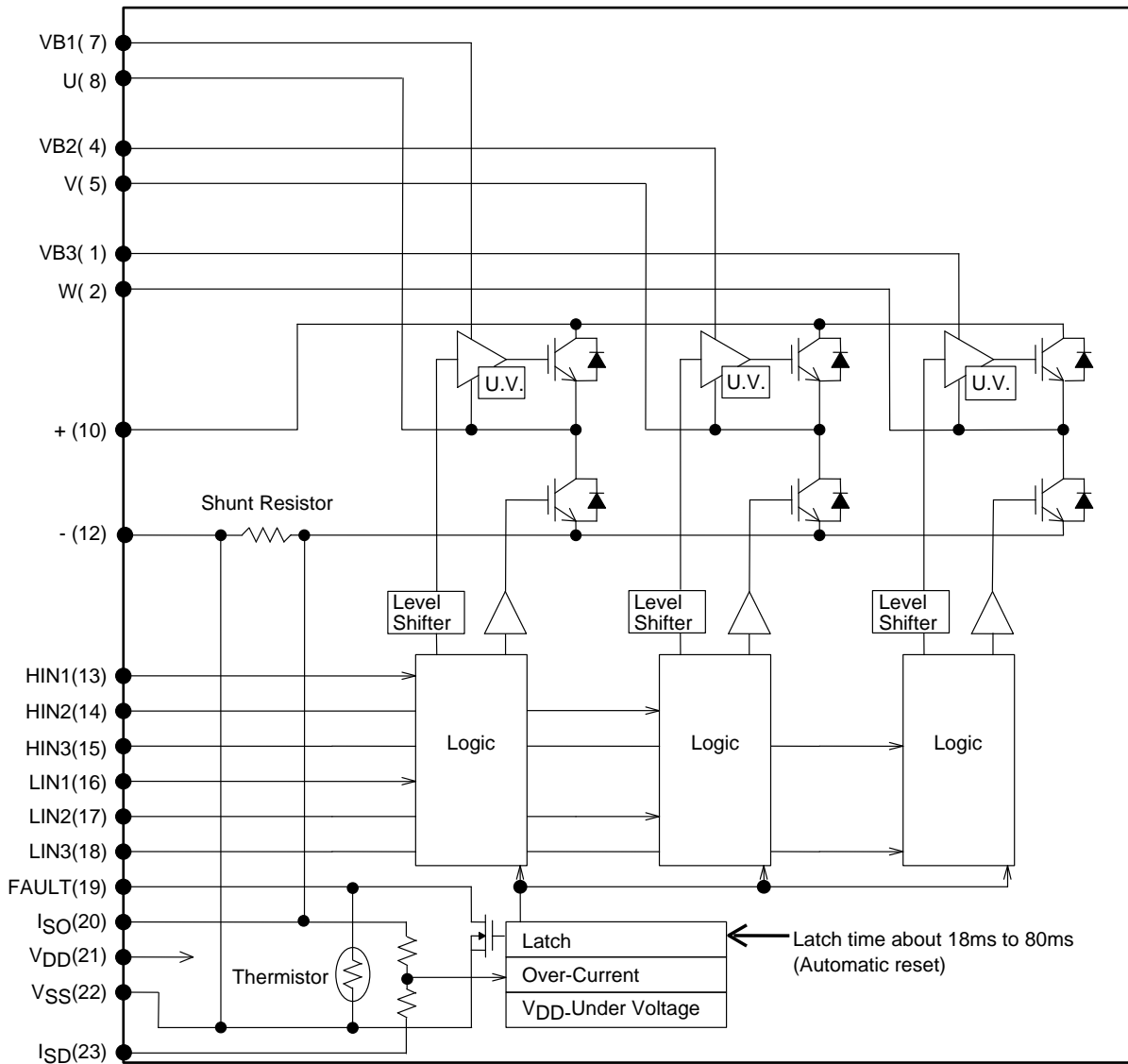

Test Circuit (Measured phase U+: upper U phase, U-: lower U phase)

Fig.1: I_{CE}

Measured phase	U+	V+	W+	U-	V-	W-
M	10	10	10	8	5	2
N	8	5	2	12	12	12

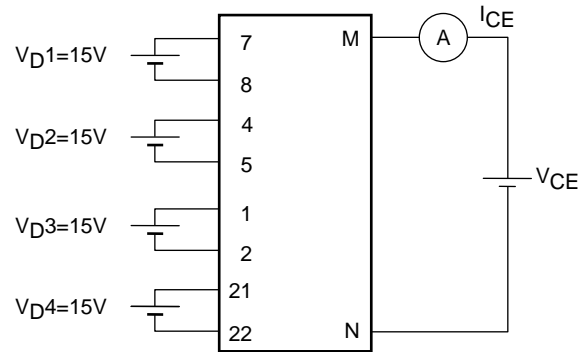

Fig.1

Fig.2: $V_{CE(SAT)}$ (Pulse measurement)

Measured phase	U+	V+	W+	U-	V-	W-
M	10	10	10	8	5	2
N	8	5	2	12	12	12
m	13	14	15	16	17	18

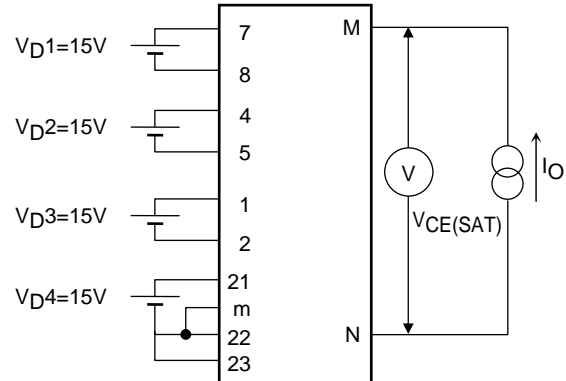

Fig.2

Fig.3: V_F (Pulse measurement)

Measured phase	U+	V+	W+	U-	V-	W-
M	10	10	10	8	5	2
N	8	5	2	12	12	12

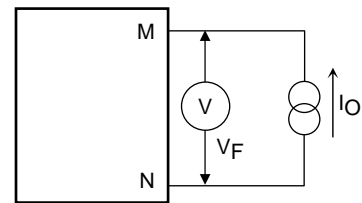

Fig.3

Fig.4: I_D

Measured phase	VD1	VD2	VD3	VD4
m	7	4	1	21
n	8	5	2	22

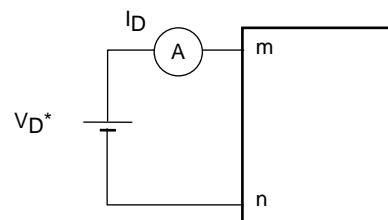

Fig.4

Recommended Operating Conditions

Parameter	Symbol	Conditions	min	typ	max	unit
Supply voltage	V_{CC}	+ to - pins	0	280	400	V
Control supply voltage	$V_{D1,2,3}$	VB1-U, VB2-V, VB3-W	12.5	15	17.5	V
	V_{D4}	$V_{DD}-V_{SS}$ *1	13.5	15	16.5	
ON input signal voltage	$V_{IN(ON)}$	HIN1, HIN2, HIN3, LIN1, LIN2, LIN3 pins	0		0.3	V
OFF Input signal voltage	$V_{IN(OFF)}$		3.5		5	
PWM frequency	fPWM		1		10	kHz
Dead time	DT	Upper/lower phase input signal downtime	2			μ s
Tightening torque		'M3' type screw	0.8		1.0	N•m

*1 Control power supply ($V_{D4}=15\pm 1.5V$) must have the capacity of $I_O=20mA(DC)$, $0.5A(Peak)$.

Usage Precaution

- The control power supply can be driven by a single power supply by connecting a bootstrap diode: DB (use a high-speed diode with a short t_{rr} and a withstand voltage of 600V or more) and a capacitor: CB (approximately 1 to 47 μ F). In this case, CB is charged by setting the lower-side device to ON (Low output). Note that a large charging current flows during startup and in other cases when the CB voltage is low, and may cause adverse effects such as noise. Be sure to connect a limiting resistor: RB (approximately several Ω to several tens of Ω).
(When not using the bootstrap method, each upper-side control power supply should be externally supplied by an independent power supply.)
In addition, the upper-side supply voltage may be insufficient depending on how the power supply is controlled, so this should be checked.
- Fluctuating spike voltage may be generated during switching operation due to the effects of the floating inductance of the + and - pin power supply external wiring or other factors. Therefore, use a short wiring length (between CI and each pin) to reduce the wiring inductance, and take measures to suppress surge voltage such as connecting a snubber circuit (capacitor: CS, approximately 0.1 to 10 μ F) for absorbing voltage surges as close as possible between the + and - pins.
- The FAULT terminal (Pin19) is an open DRAIN type output (FAULT operation when it is low).
The STK621-043A-E has a built-in thermistor between the FAULT and V_{SS} terminals. It allows monitoring the substrate temperature using the divided voltage developed with the pull-up resistor RP.
The resistance of the RP must be 10k Ω or higher at a pull-up voltage VP of 5V and 39k Ω or higher at a pull-up voltage VP of 15V.
- I_{SO} terminal (Pin 20) is for the electric current monitor. The external impedance must be 5.6k Ω or higher. Never connect between I_{SO} and V_{SS} terminals. Short-circuiting them may cause an excess current flow into the line and a hazardous situation may result.
- A 5V (5.0 to 5.4V) Zener diode is connected inside the signal input pins. When inputting voltage in excess of 5V, connect a resistor between the power supply side and the signal input pin so that the input current to the signal input pin is 0.5mA or less. This resistor is also effective for absorbing noise.
- The overcurrent protection function is valid only when circuit control can be performed normally. Be sure to provide a fuse in the V_{CC} line or otherwise ensure safety in the set design.
- The IC may become damaged or rupture if the motor connection pins (pins 2, 5 and 8) are open during motor rotation. Take special care for the connections (soldered condition) of these pins.
- The overcurrent protection feature operates normally when an external resistor R_{SD} is connected between the I_{SD} and V_{SS} terminals. Be sure to connect this resistor (or short-circuit) between them. The level of the overcurrent protection current can be lowered by using the external resistor R_{SD} .
- If the - terminal and the V_{SS} terminal are short-circuited externally, since an overcurrent protection value (I_{SD}) may fall below the value set inside the HIC due to adverse effect of wiring, it is required to check the condition with the actual unit when designing. (-terminal and V_{SS} terminal are connected inside HIC)