

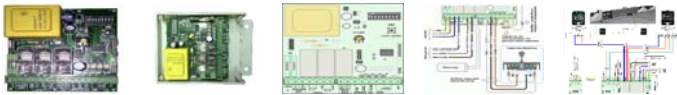

## Electronic control panel for sliding door devices 230VAC

230 Vac - Remote Control - 250 Controls - External Sensors - Signal Light - Auto terminal switches



## AUTOTECH S-5060 - Electronic control panel for sliding door devices 230VAC

The electronic control panel (board) for single phase mechanisms sliding doors 230 V AC, S-5060T type , from the company AUTOTECH.

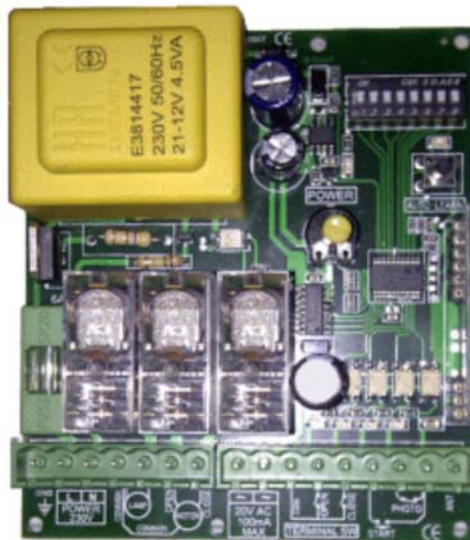

### Key features



- Set the motor power (POWER).

In this way, security achieved in case of obstacles of the door path. This function is the last protection for the trapped objects by the moving door leaf and does not replace the use of photocells safety.

**Note**, the table comes with the motor power to set the maximum value and the user do the setting to the desired level.

- \* The mode start slowly (soft-start) for smoother motion of the door. The function can be deactivated through the menu.
- Slow operating system (soft-stop) for smoother motion of the door. The movement time in slow speed is adjustable from 1 to 9 sec, through the menu, while the function can be disabled. The table automatically learns the journey for the first time to perform the fully open-close.
- Working with the motor terminal switches. The terminal switches of the controllable motor connected with the table when one of them zero the operating time and the next command will be reverse motion.
- Automatic shutdown after the expiration adjustable year (automatic closing). If the user wishes to give the table a command of close after a waiting period. This period is adjustable to 30, 60 or 120 sec via DIP-switches (DIP- switches #2 & #3), while this operation can be disabled.

**Note**, the table is delivered with disable operation and if the user want it, must do the setting to the desired time.

- Automatic synchronization to the wireless transmitter (remote control) and rolling code receiver. When the electronic control combined with a suitable receiver programming RF, like the AT-434-SBW, the transmitter and the remote receiver will start the automatic synchronization very easy by pressing the button AUTO LEARN. During this process, the transmitter (remote control) and the receiver "learn" each other, while in future they can "talk" with safety. Skipping the technical details, we mention that is a highly secure method of transmitter- receiver communication that makes it practically impossible to "tricked" the receiver.
- Easy connection of the alarm lamp or light bulb 230 VAC. The connection of the alarm lamp, flashing when the door is in motion, it becomes very easy via the two contacts in the terminal clump. Alternatively, instead of a lamp you can connect a standard light bulb to the same contacts and change the selection of the switch, so you will have lights in our garage while the door is in motion and even 60 sec after it stopped.
- Input for photocells safety or edge of safety.
- Easy configuration of opening direction via a programmable DIP switch.
- Input for the command button (START).
- Adjustable response to the commands via buttons.

- > The typical response sequence is: OPEN – STOP – CLOSE – STOP – OPEN -
- > The alternative response sequence is: OPEN only.

- Low voltage for the power supply components (eg photocells safety).
- It is designed to receive 433.92 MHz the wireless remote control receiver RF, in module form, AUTOTECH AT434SBW. When the remote receiver, recording, deleting, and the compatible using of remotes, like AUTOTECH SM50P , there are very easy to install.

**Note**, the table delivered with the receiver installed.

- SMD Technology.
- Certification CE.

### Basic Installation Instruction

**Note:** These are basic instructions given for your convenience. For detailed instructions, refer to the manufacture manual supplied with the control panel. In any case, the manufacture manual is the only authoritative source of informations.

First of all, you must know the wiring and programming of an electronic control panel because is a process that requires basic skills. If you do not have experience with this tables, you must first familiarize with the features and how it works and programmed.

CAUTION:

There should be no works on the table when he is under voltage (connected in power supply). All the connections must be made by the disconnected panel from the power supply.

For security:

- disconnect the table from the current,
- take all necessary measures to avoid the mistake of reconnection,
- do the connections with the right way,
- reconnect the table with the current,
- make settings and testing, with great attention.

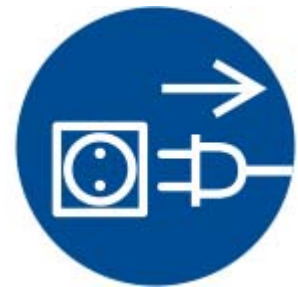

Also, you must not miss the correct connection between device and grounding cable from the power supply cable.

### Power Supply

- The power supply must be from a separate line with own safety device in the power supply board and properly grounded. In this line we must not connect other device.
- The required safety device in the current board (security) is Differential Switch Bipolar tension (DSB - not electric shock, safety relay, leakage circuit breaker or spillage relay as they used to call the technicians) with rated current 6A and trigger operating 30 mA or less. Note, the national standard ELOT HD 384 based on and requires DSB for the facilities that extended outside the building.
- The minimum section of power supply cable is 3, 1.5 mm<sup>2</sup> (phase, neutral & ground).

### Familiarity with the table

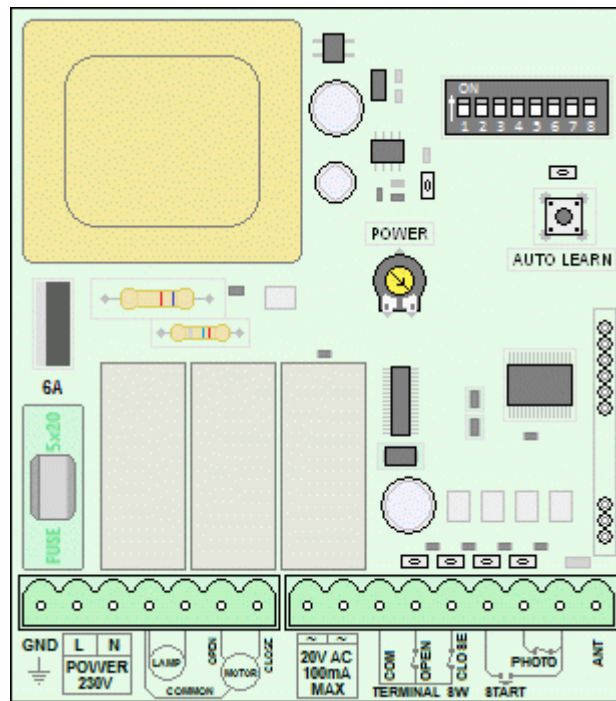

Over the table prevails the adapter with 3 relays in line just below and 6A fuse at the left.

There are two split clamps at the bottom:

- At the left is the strong current clamp where connect in line with the power supply, the alarm lamp and the motor. All this contacts have voltage 230 V AC and obviously require attention at work.
- At the right is the clamp device, control and security. Here in line, there are contacts with voltage 20 V AC for the accessories, the contacts of the terminal switches opening and closing, the contacts for the command connection of open/close and the photocells contact for the remote control receiver antenna (insulated 17 cm cable length, already connected contact).

### Indicative LEDs

The table has a series of LED lights:

- The first four LED (L1 through L4) are aligned over the contacts to the clemp devices, control and security. Each of them connects with a contact(switch). The rule is: LED on = closed contact.
- The L5 is above the AUTO LEARN switch in the upper- right corner of the table and give indications of any motor overload and learning function of the remote control transmitter.
- The L6 is just right and above the center of the table and give indications for feeding the stream table.

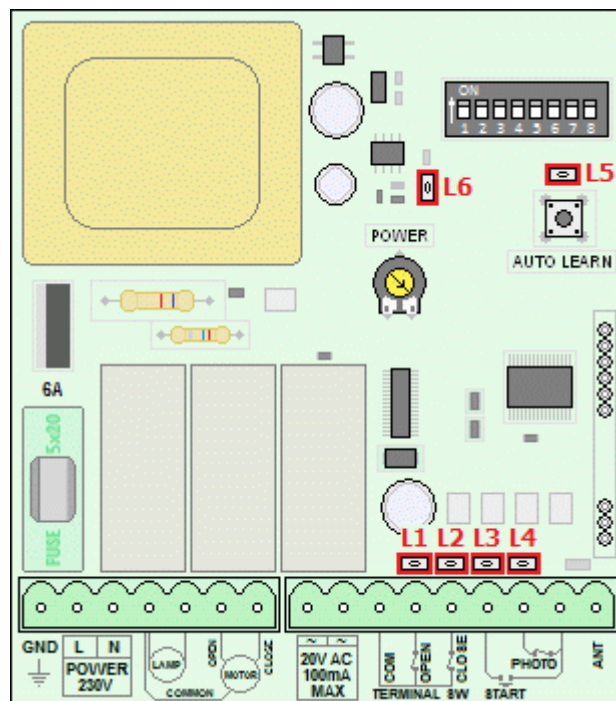

<b>L1 OPEN</b>	Terminal switch mode for open door position.
On:	Terminal switch is off.
Off:	Terminal switch is on (the door is completed closed).
Switch Type:	NC
Normal mode:	<b>On</b>
<b>L2 CLOSE</b>	Terminal switch mode for close door position.
On:	Terminal switch is off..
Off:	Terminal switch is on(the door is completed opened).
Switch Type:	NC
Normal Mode:	Off
<b>L3 START</b>	Button Situation.
On:	Button switch is closed (the button is pressed).
Off:	Button switch is opened (the button is not pressed).
Switch Type:	NO
Normal Mode:	Off
<b>L4 PHOTO</b>	Photocell safety situation.
On:	Photocell switch is closed (the photocell safety not detect obstacles).
Off:	Photocell switch is opened (the photocell safety detect obstacles or have problem).
Switch Type:	NC
Normal Mode:	<b>On</b>
<b>L5</b>	Learning mode indicator of the remote transmitter.
It is on for 10 sec after we pressing the button AUTO LEARN:	
	The automatic synchronization of the wireless transmitter (remote control) and the rolling code of the receiver can be made as long as the LED stays on.
It is flashes after we hold pressed the button AUTO LEARN for at least 10 sec:	
	Releasing the button AUTO LEARN, all programmed transmitters will be erased from the memory of the remote control receiver.
<b>L6</b>	Indication of power supply.
On:	The control panel is connected with the current.
Off:	The control panel is not connected with the current.
Normal Mode:	<b>On</b>

- When the door is fully closed and all the switches (non-terminal) have the standard condition.

- The indications of L1 / OPEN and L2 / CLOSE apply the factory settings of table to open to the right.

## Strong currents clamp

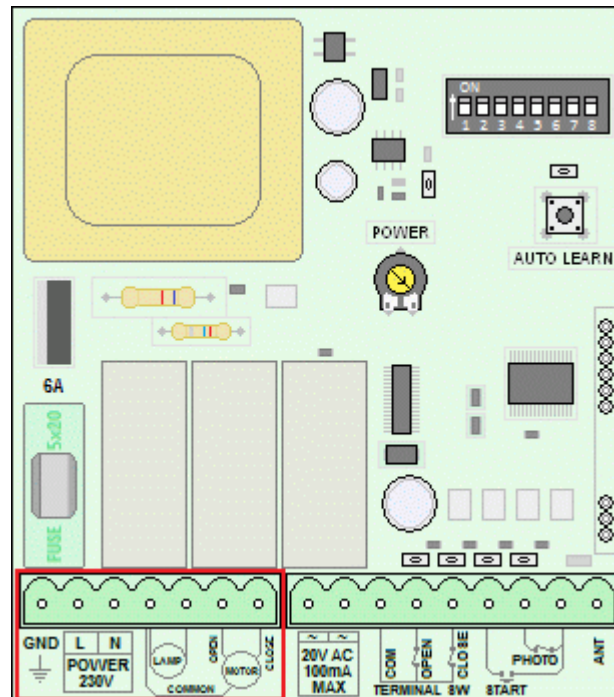

- **GND & POWER 230V:** At first, left contact is marked as GND and connect with the ground of the power supply. Note, the ground of the power supply must be connected with the table AUTOTECH S-5060 and the motor or the trunk of the mechanism. In the next two left contacts is marked as POWER 230V, and connect the current with the network. At first (L) contact we connect with the phase and at the second (N) contact with the neutral. We can easily find the phase using a test screwdriver.
- **COMMON:** Since we have connected the previous L and N contacts, this is contact is neutral for the lighting lamp/alarm lamp and for the motor windings.
- **LAMP:** The contacts are marked as COMMON and LAMP, connected with the alarm lamp or the lighting lamp. This equipment is optional and used with the alarm lamp but is not necessary or associated with the good functioning of the motor. The operation mode of this contact depends on the setting of #1 Dip switch.
- **OPEN and CLOSE:** Between the COMMON, OPEN and CLOSE contacts are connected with the motor. In fact, if it has not been turned on the counter-clockwise opening (via a #8 Dip switch), the motor winding takes current from the contacts CLOSE and COMMON to have the desired direction of opening the door whereas for closing used the contacts CLOSE and COMMON. Also note, the contacts OPEN and CLOSE connected with the motor capacitor (usually has a cylindrical shape). In any case we do not remote the capacitor from the control panel.

## Handling clamp and safety devices

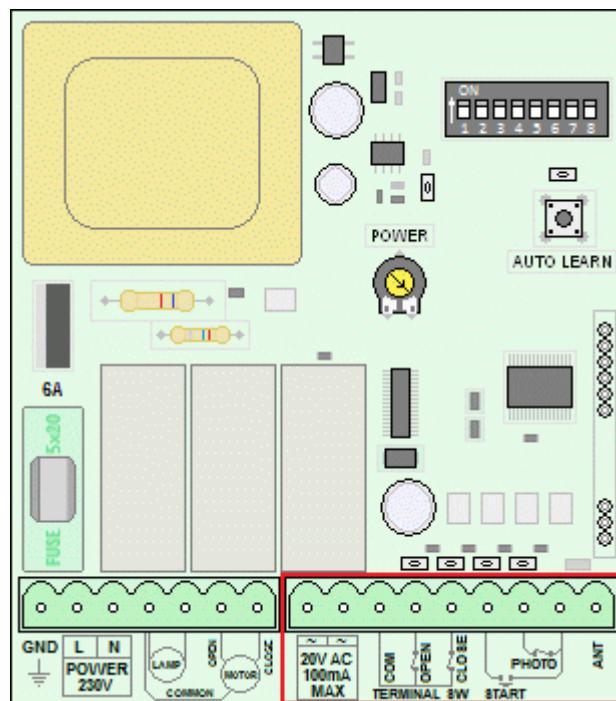







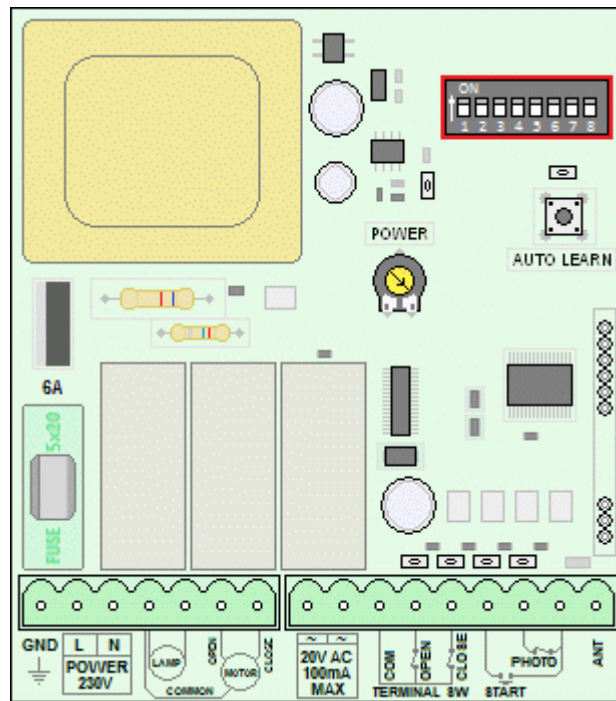





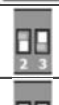



- **20V AC:** The first two contacts from the left, which marked as 20V AC / 100mA / MAX, are useful for low voltage devices to supply power such as photocells safety.
- **COM:** The next contact, which is marked as COM , are neutral for the terminal switches.
- **OPEN:** The contact OPEN is for connection of the open terminal switch (gives signals to the door to have fully open position).The open terminal switch connected with this contact and contact COM which is type NC (Normally-Closed). If for any reason we do not use open terminal switch, we must bridge this contact with a contact COM.
- **CLOSE:** The contact CLOSE connecting with the close terminal (gives signals to the door to have fully close position). The close terminal switch connected with this contact and contact COM which is type NC (Normally-Closed ). If for any reason we do not use close terminal switch, we must bridge this contact with a contact COM.
- **START:** The contact START connecting with the control button. The control button connected with this contact and contact COM which is type NO (Normally-Open). If we do not using a control button, we do not connect anything to this contact.
- **PHOTO:** The contact PHOTO connecting with the photocells safety. The photocells safety notify for a obstacle detection via a open switch and connected with this contact and contact COM which is type NC (Normally-Closed). If for any reason we do not use photocells safety, we must bridge this contact with a contact COM.
- **COM:** The penultimate contact (not name) is another neutral for connecting the command button and the switch command from the photocells safety.
- **ANT:** The last contact ANT, is substantially the location where the antenna connected with the remote control receiver. This antenna usually has the form of a single cable length of 17 cm . If you have connected remote control receiver with the control panel, you should not remove this antenna because the remote range will be vanish.

## Dip-switches

The control panel S-5060 has in line 8 dip switches. In normal mode, the 8 dip switches are in position OFF (down).



		
<b>Dip switch #1</b>		
OFF		For connecting the alarm lamp. The lamp flashes when the motor is operating. Use standard operation lamp continuous- the flashing is done by the board.
ON		For connecting the light bulb. The lamp continuously lights up when the motor is operating and turns off after 60 sec.
<b>Dip switch #2 &amp; #3 (combination)</b>		
OFF-OFF		Without automatic closure.
ON-OFF		Automatic shutdown after 30 sec.
OFF-ON		Automatic shutdown after 60 sec.
ON-ON		Automatic shutdown after 120 sec.
<b>Dip switch #4</b>		
OFF		At the end of each movement are slowly stop. The motor slows down with low speed when the leaf is nearing to end of the path. Note, the table measures the time which needed for opening/closing the door in each operation cycle.
ON		Without slow stop(soft-stop).
<b>Dip switch #5</b>		

OFF		With electric braking at the end of each movement.
ON		Without electric braking .
<b>Dip switch #6</b>		
OFF		Following commands: OPEN-STOP-CLOSE-STOP-OPEN-... This is the typical sequence of commands.
ON		Following commands: Only OPEN Useful with the combination of activated setting for automatic closure devices which have connection with the access control (access-control) or control the button when there is no visual contact with the door.
<b>Note:</b> Following commands performs the table via the embedded remote control receiver( OPEN-STOP-CLOSE-STOP-OPEN-... ) and are not affected by the setting of the Dip switch #6.		
<b>Dip switch #7</b>		
OFF		With a slow start (soft-start). The motor starts the moving with a slow speed and later speed up to normal speed.
ON		Without a slow start (soft-start).
<b>Dip switch #8</b>		
OFF		Normal opening time. Typically, the table connects with the door for right open (as looking the motor and back of the door leaf).
ON		Reverse opening. Makes the table to behave like as we reverse the motor cables and terminal swith to change the direction of opening.

### Motor power adjustment potentiometer

The control panel S-5060 has a motor power adjustment potentiometer. In normal mode, the potentiometer, is in the right position end (maximum power).

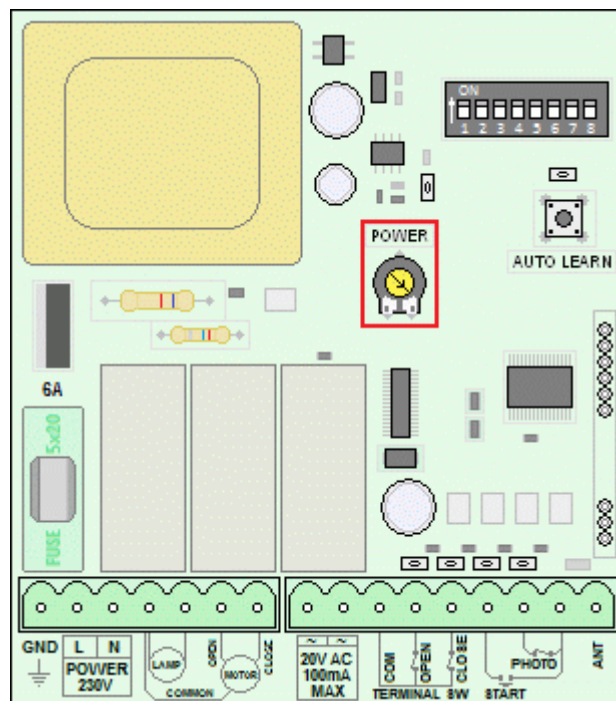

	<p><b>POWER</b> motor adjustment potentiometer.</p> <p>The motor power is adjusted via a POWER potentiometer. In the right position, the motor holds the maximum power and hold the left position to the minimum.</p>
--	---

### Built-in remote control receiver

The control panel S-5060 has a button which activates the automatic synchronization process to wireless transmitter (remote control) and the rolling code of receiver. The button AUTO LEARN is above of the LED L5 and inform the status of the process.

To enable this process, you must be connected the wireless receiver with the control panel. Typically, this is the AT-434-SBW and has the form of a small board, connected with the specific contacts on the right side. The following concerning the function of the combination S-5060 & AT-434-SBW. Note, it is possible to enter up 15 remotes control in the memory, with their own personal identities.

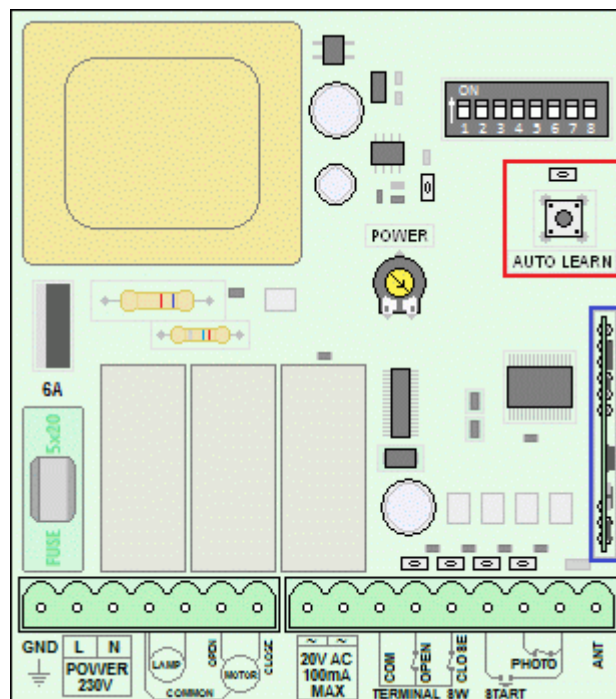

### Wireless remote registration

Press the button AUTO LEARN once and leave it. The LED L5 stays on for 10 sec.

During this time, the remote control receiver can be connected with a wireless remote control and register it in memory, which has individual identity. To do this, you must simply press the button on the remote because we want to give a command to the remote control receiver.

If the remote control receiver already has 15 registered remote controls and adds another one, then the older remote control will be erased from the memory and will be replaced by the new one.

If we do nothing during these 10 seconds, the LED L5 is off without making any changes to the list of remote controls which identifies the remote control receiver.

### Delete all registered remotes in the wireless remote tuner

Press the button AUTO LEARN and hold it for 10 seconds. The LED L5 starts to flash. All registered remote controls are now erased from the memory of the remote control receiver.

### Current connection

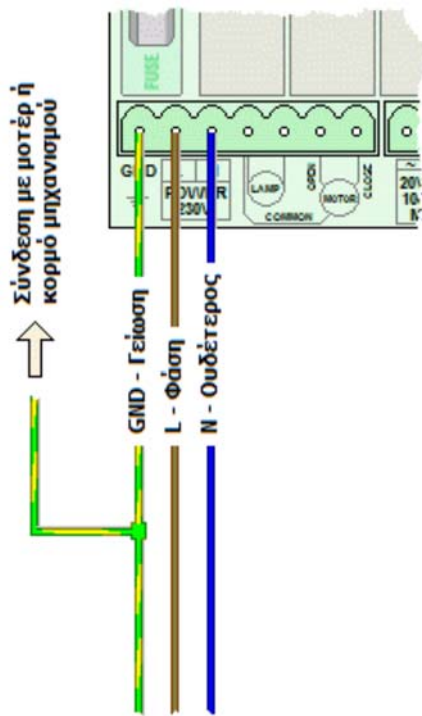

The current connection is made to the block power clamp, like as the figure.

- The neutral and the phase is connected with the correct contacts (eg using the test screwdriver).
- Although the ground connection is in the table and also connect the ground with the motor (if the motor cable has a ground wire) or trunk mechanism.
- If the opening and closing of the door are in the wrong directions (eg, when the photocells detect an obstacle, the door close instead to open), do not change the phase and neutral. The setting of correct reference must be made via the Dip switch #8 .

When we connect the table with the current or a power failure, **the first command receives (via a remote control or button), will be interpreted as a command to open the door.** This is an easy way to check if the opening-closing is right or should we change it (as in the next section).

## Directional opening-closing control

The motor mechanism of slidings doors typically have two windings. Each winding, gives a particular direction of rotation when current flows and two of them corresponding to reverse rotation (one for opening and one for closing the door).

Also, the motor mechanism of slidings doors typically have two terminal switches. One switch must be activated when the door is in open position (OPEN) and the other is activated when the door is completely closed (CLOSE).

In this table, the motor and terminal wiring is as shown below.

**Note, the color of cables may be different on the mechanism which installed in the table.**

- The motor connection became from the contacts COMMON, OPEN and CLOSE, in clamp force. The contacts OPEN and CLOSE connected together and the motor capacitor usually has a cylindrical form. In no case, does not disconnect the capacitor from the contacts.
- The motor connection became with the contacts COM, OPEN and CLOSE, in the components clamp.

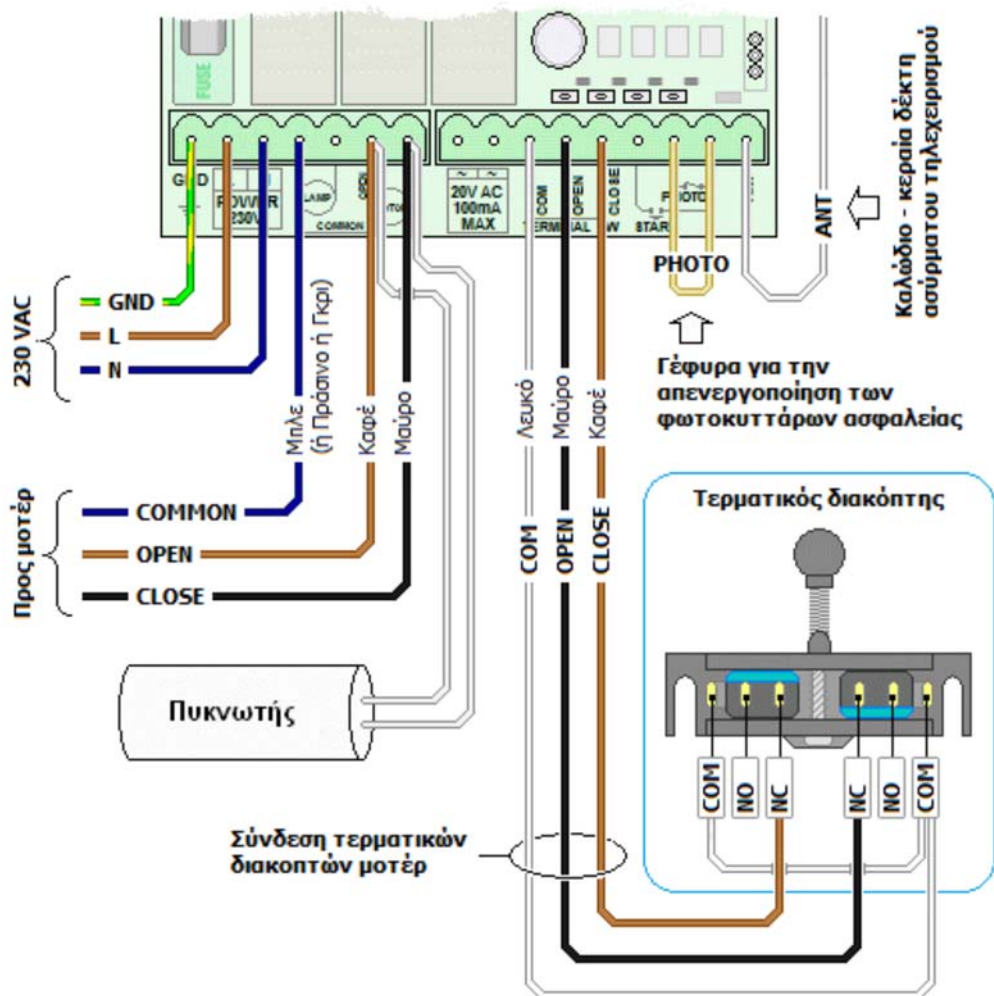

Depending on the position of the door and control command, the table turns on the motor winding and the result will be in proper motion of the door and interpreting the commands of the terminal switches such as completely open or close.

However, the motor can be installed either right or left side of the door and the table can not know if opening/closing of the door is in the wrong direction (eg, when the photocells detects an obstacle, the door closing instead of opening) must set the opening time so your motor will be working properly.

In most cases, the tables of sliding mechanisms are connected with the factory which the opening is at the right. If do, then the setting of the direction of opening done via Dip switch #8, as in the following figures:

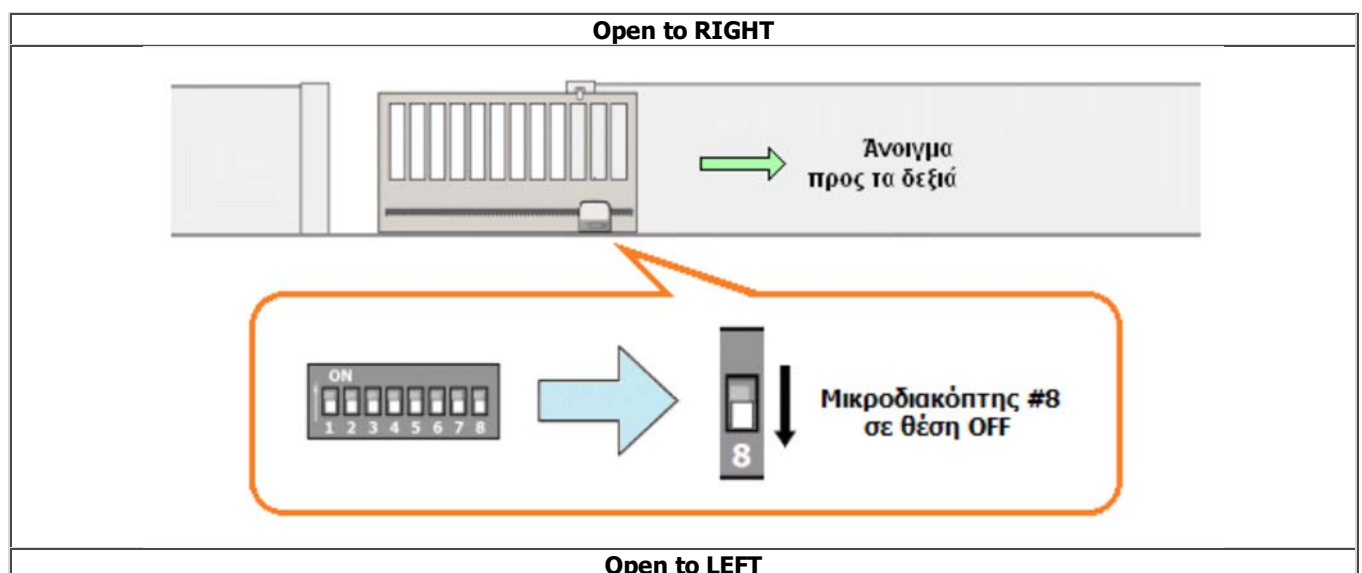

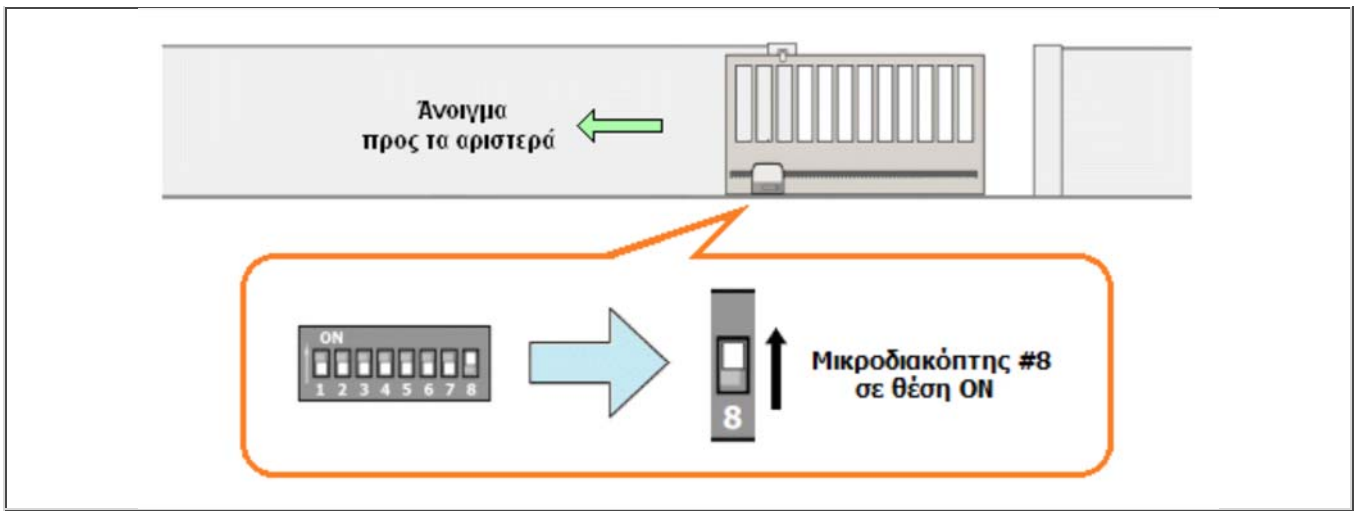

Notes:

- Everyone can change the direction of opening with changing the wiring (ie alternating, in the above figure, the black with the brown color of the connections motor and terminal). However, we do not recommend and we believe that it's not worth.
- If the position of the Dip switch #8 is in ON, then the labels OPEN and CLOSE on the table and the terms of the respective LEDs are reversed (eg for example, the table gives current to the contact CLOSE to make closure and gets signal from the contact CLOSE of the terminal switches to realize that the door is open).

### Alarm lamp or lamp lighting connection

In this table it is possible to connect either alarm lamp or lamp lighting bulb. But we can not have simultaneously.

The alarm lamp or the light bulb must have power supply of voltage 230 VAC . Also, the alarm lamp should be in continuous operation (have not features own circuit for the flashing - the flashing is made from the same table).

To choose one of the two functions, we must properly set the Dip switch programming (dip-switch) #1:

DIP Switch #1		
OFF		For the alarm lamp connection. The lamp flashes when the motor is working. Use standard continuous operation lamp - the flashing is done from the table.
ON		For the light bulb connection. The lamp continuous lights un when the motor operation is turn off for 60 sec.

The connections of alarm lamp or light bulb made between the two contacts of the strong current terminal with the labeled 'LAMP':

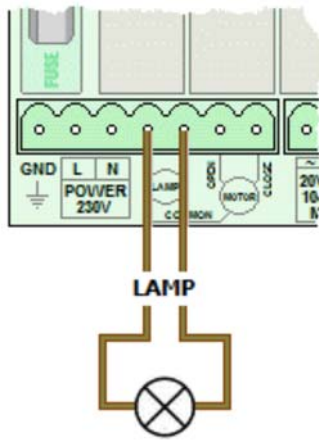

## Terminal devices, control and security connections

The connections of the specific clamp, the various devices handle the mechanism (eg button), the devices control the proper function (eg terminal switches) and devices which provide safety (eg photocells safety).

### Basic connection with the terminal switches, without photocells safety

If the table is already mounted on the motor, like the left figure.

The three wires of the left, concern the terminal switches on opening. Typically, the table is delivered with bridged contacts which corresponding the switch that provides us the photocells safety. Finally, the last right contact, is connected the table with the antenna of the wireless remote control receiver.

- **Terminal switches motor**

In a sliding motor, there are two terminal switches which are activated when the door comes to open completely (COM with OPEN) and close completely (COM with CLOSE) respectively position. These switches are type NC (Normally-Closed). If for any reason we don't have terminal switches in our application, we must bridge these contacts.

- **Photocells safety switch** To be easy the control operation process of the motor even more before the photocells safety connecting, we use the above bridge to essentially disables the operation. For informations on photocells safety, see the below section.

- **Cable-antenna of the wireless remote control receiver** It is important, if we have installed the specific wireless remote control receiver, do not remove this cable. Otherwise, the remote range falls vertically.

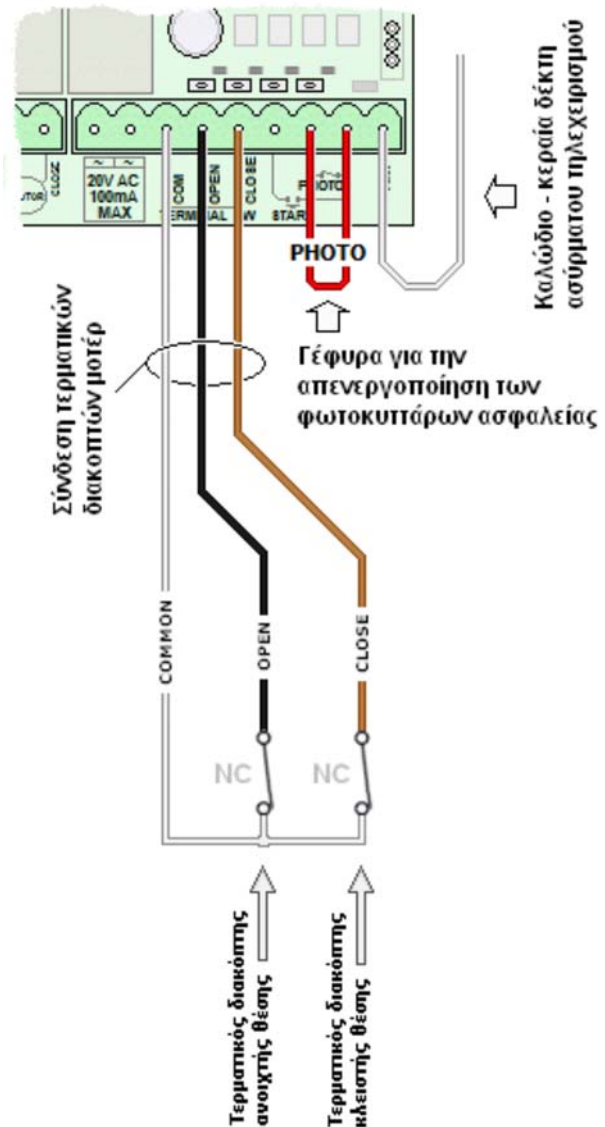

### Button command connection

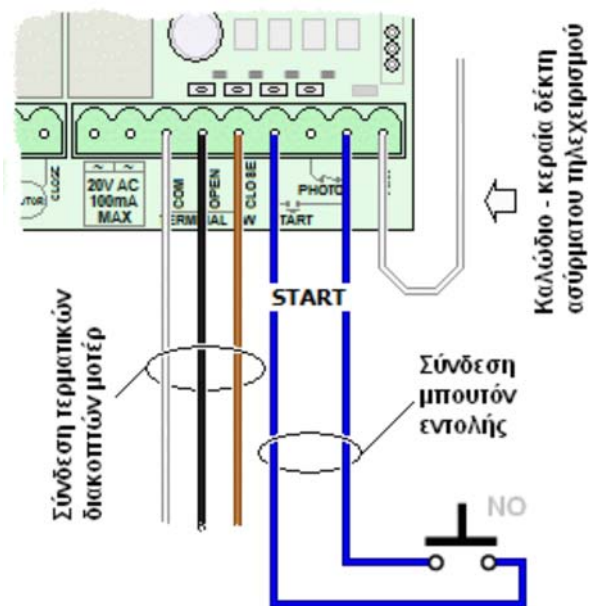

To connect the button command, we use the contacts START, as in the diagram. The button controls are essentially, switches NO (Normally-Open).

If you want to connect more than one command button, then the correct wiring is in parallel as in the figure:



The response of the table is in successive commands via buttons which depends on the setting of the DIP switch#6:

DIP Switch #6		
OFF		Following commands: OPEN-STOP-CLOSE-STOP-OPEN-... This is the usual following commands.
ON		Following commands: OPEN only Useful, in conjunction with activated setting for automatic closing devices for access control connection (access-control) or button control when there is no visual contact with the door.

Note: the following commands performs the table commands via embedded control receiver ( OPEN-STOP-CLOSE-STOP-OPEN-... ) is not affected from the setting of the Dip switch #6.

### Photocell safety connection

The photocells safety, act as a switch type NC (Normally-Closed ) which opens when detected obstacle. Consist a pair of transmitter (TX) and receiver (RX).The transmitter emits a narrow beam of light and when obstacle not interfere, the receiver receives it.

The specific control panel recognizes only photocells safety for protection when the door is closing. If it is necessary to use photocells safety for protection when the door is opening, we must check an astute control panel.

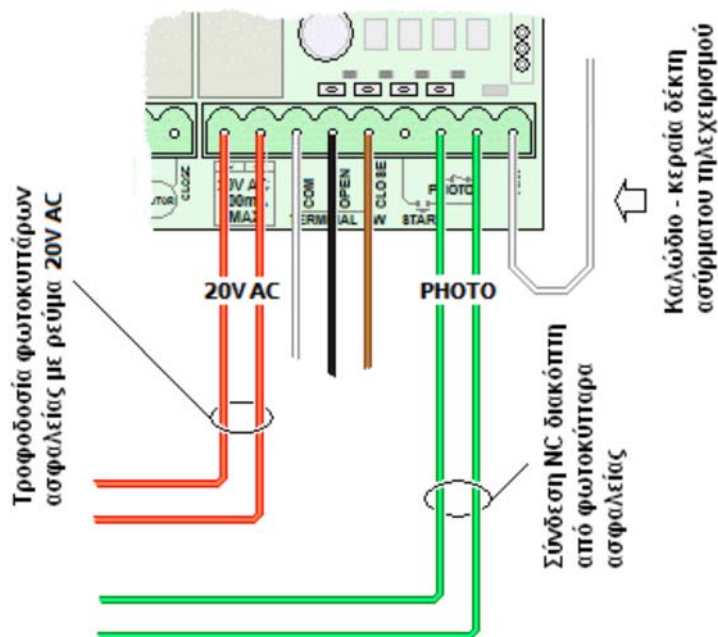

To connect photocells safety, we use the following contacts:

- For the power supply with current, the two contacts 20V AC.
- For the connection from the switch NC that provides photocells safety, contacts PHOTO.

Obviously, when connect photocells safety, we must remove the bridge between the contacts PHOTO.

If we want to connect more than one of photocells safety, then the correct wiring, with the switch NC, is in line as in the figure:



**Wiring examples** In this article we will find a detailed wiring from the side of photocells, for some types of photocell we have.

### Check if the photocells safety have correct operation

After connecting the photocells safety we must check for correct operation. We practice the activated photocells by the presence of obstruction and the control panel gives command for safe movement. In case of problem, over the indicative sings who provide the photocells safety (usually features a indicative LED, and typically you can hear the light "click" that makes the arming relay) also we must check if the the commands arrive correctly in the control panel. For this reason, we look at the LED L4 - PHOTO: should be on the absence obstacle and with obstacle close.

### Check if the automation have correct operation

When the installation completed, we must check the behavior of the whole mechanism to ensure that we are completely satisfied.

As a first step, we must sure that all of our cables are made correctly (no loose contacts, stripped wires, the cables are not squeezed or stretched too etc) and that we ensure the tidiness and tightness of the box which hosting the control panel. Not secured the cap on the box of the control panel.

Disconnect the control panel from the current, the mechanism disengages and manually bring the door in half opened position. Then re-interlaced mechanism and reconnected the control panel with the current. This is done because we must sure that actually we check the correctly time of the door opens. With the control panel back on current, the first command we give will be done with remote control or the button.

We control all the commands devices (eg what happens when we press the button or the remote control at different stages of mechanism operation like as the door is opened/closed or when opens/closes), security (eg what happens when the photocells safety activated), warning (eg if the alarm lamp works properly) but the whole behaviour. We must watching at the same time the indicators LED from the control panel to see if the signs are as expected.

We make sure that everything works correctly, apart from the control panel, the mechanism as a whole works flawlessly.

In the end, secures the cap on the box of the control panel.

