



MVR-606-2IP 6ch Mobile DVR

Quick Guide

This manual was complete and correct at the time of printing. The ongoing development of the products may mean that the content of the user guide can change without notice. The manual will be kept updating periodically, and software referred as well.

© 2015 ViPRO Corporation

-
-

NOTICE

The information in this manual was current when published. The contents of this manual are subject to change without prior notice and will be updated accompanying with the release of new version.

The purpose of this manual is to kindly aid the user for the operation for our MDVR (especially for GUI setting). The user should have a basic understanding of computer operation and basic knowledge of how to connect peripherals and make some settings.

Guarantee & Warnings

1) Electrical Apparatus Safety

All installation and operation should comply with local electrical safety norms.

2) Transportation

In the process of transportation, storage and installation, please avoid heavy stress, violent vibration, impact and water splashing.

3) Installation

Install the equipment in accordance with the requirements, handle carefully. Do not heavily press the equipment before the MDVR installation is finished.

4) Requirements on Engineers & Technicians

All the work of checking and maintenance should be done by qualified engineers. We do not undertake any problems caused by unauthorized modifications.

5) Requirements on Environment

The equipment should be installed and stored in a cool and dry place, away from direct sunlight, flammable or explosive substances, etc. Keep gaps not less than 3cm around the device to facilitate ventilation for cooling.

6) Accessories

Make sure to use accessories from the manufacturer suggested in the attachment.

Insulate circuit ground and metal shell for all the peripherals.

Before installation, please open the package and ensure that all parts are included.

If there are any problems, please contact us as soon as possible.

1. PRODUCT CHARACTERISTICS

1.1. OVERVIEW

MVR-606-2IP is a functional Mobile Digital Video Recorder specially designed for vehicle video surveillance and remote monitoring. It has a high-speed processor and embedded operating system, combining with the most advanced H.264 video compression / decompression technology, 3G/4G network, GPS positioning technology, as well as WIFI. It supports not only video recording in 720P, WD1, WHD1, WCIF, D1, HD1 and CIF formats, but also vehicle travel information recording and wireless data upload. With center software it also achieves alarm linkage central monitoring, remote management and playback analysis. It is easy to use with simple design, multi-functions, superior anti-vibration, flexible installation and high reliability.

1.2. SPECIFICATIONS

Item		Technical Index
Product series		MVR-606-2IP
Function Overview		Preview, Recording, Playback, Network, Locating
System	OS	Linux 3.0.8
	Control Mode	CP4, Easy Check, network, mouse
Video	Input	4 channels WD1+2 channels 720P
	Output	1 channel
	Total Resource	(4 x 25)FPS WD1 @ PAL / (4 x 30)FPS WD1 @ NTSC + (2 x 30)FPS 720P
	Video Signal Standard	Electrical level: 1Vpp Impedance : 75Ω NTSC/PAL Optional
Audio	Input	6 channels (Including IPC x 2)
	Output	1channel
	Audio Signal Standard	Electrical level: 2Vpp Input impedance: 4.7kΩ
Display	Display Split	1/4/9
	OSD	GPS information, alarm, vehicle No., speed, date/time
	Operation Interface	Semi-transparent GUI
Recording	Video/Audio Compression	Video: H.264 Audio: ADPCM, G.711A G.711U
	Image Resolution	Analog: PAL:WD1(928X576), WHD1(928X288), WCIF(464X288), D1(704X576), HD1(704x288), CIF(352x288); NTSC:WD1(928X480), WHD1(928X240), WCIF(464X240), D1(704x480), HD1(704x240), CIF(352x240); Digital: 720P(1280X720);

	Image Quality	1-8 levels adjustable (1 is the best)
	Recording Mode	Boot up/Manual/Schedule/Alarm (sensor trigger, speed, acceleration, video loss, temperature)
	Pre-recording	0-60minutes
	Post-recording	0-30 minutes
	Mirror/Dual Recording	Support
Playback	Playback Channel	1 channel by local playback
	Search Mode	Date/time, channel, event
Network	Ethernet	RJ45(10/100M) x1
	IPC Ethernet	6-pin DJ M12(10/100M x 2, PON power supply)
	WIFI	802.11b/g/n
	3G/4G	EVDO/WCDMA/TDD-LTE/FDD-LTE
Locating	GPS	Location tracking, speed detection and time sync
Storage	Hard Disk	2.5" SATA hard disk x 1(Up to 2 TB)
Interface	USB	USB2.0 x 2
	SD	SD x 1
	SIM	SIM x 1
	RS232	RS232 x 2
	RS485	RS485 x 2
	Sensor	8 inputs, 2 outputs
	Serial	G-sensor (Internal)
	Speed	1 channel pulse speed detection
	Interface	Interface (CP4 Optional)
Power	Input	DC8-36V
	Output	12V@1A, 5V@1A
	Max Power Consumption	69.9W
	Standby Power Consumption	≈0W
Others	Water Proof Rate	IP54
Physical Characteristic	Dimension (L x W x H)	255.3mmx150mmx89.1mm / 10.05" x 5.906" x 3.508"
	Weight	2.2Kg / 4.85lbs
Environment	Operating Temperature	-40°C - +70°C / -40°F - +158°F (With heater) or -10°C - +70°C / 14°F - +158°F
	Operating Relative Humidity	8%-90% (No Condense)

1.3. SYSTEM DIAGRAM

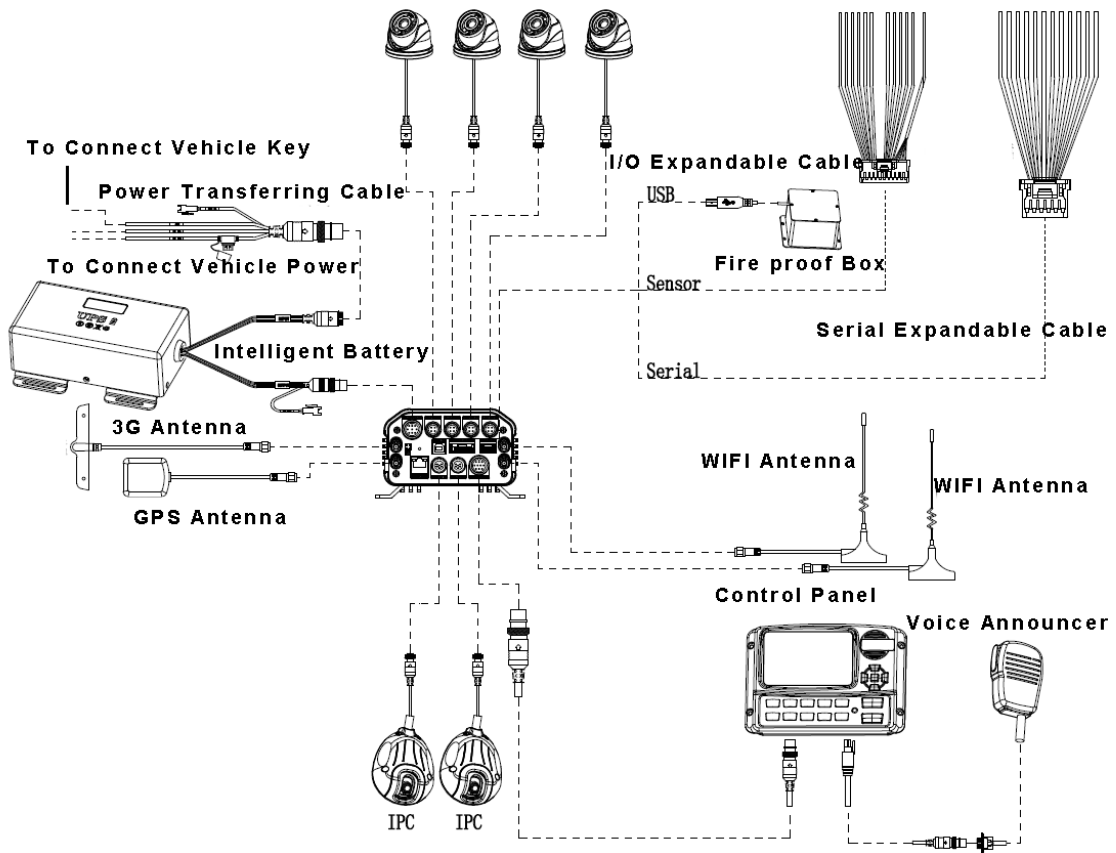

1.4. EXTERNAL INTERFACE

DIMENSION (Unit: mm)

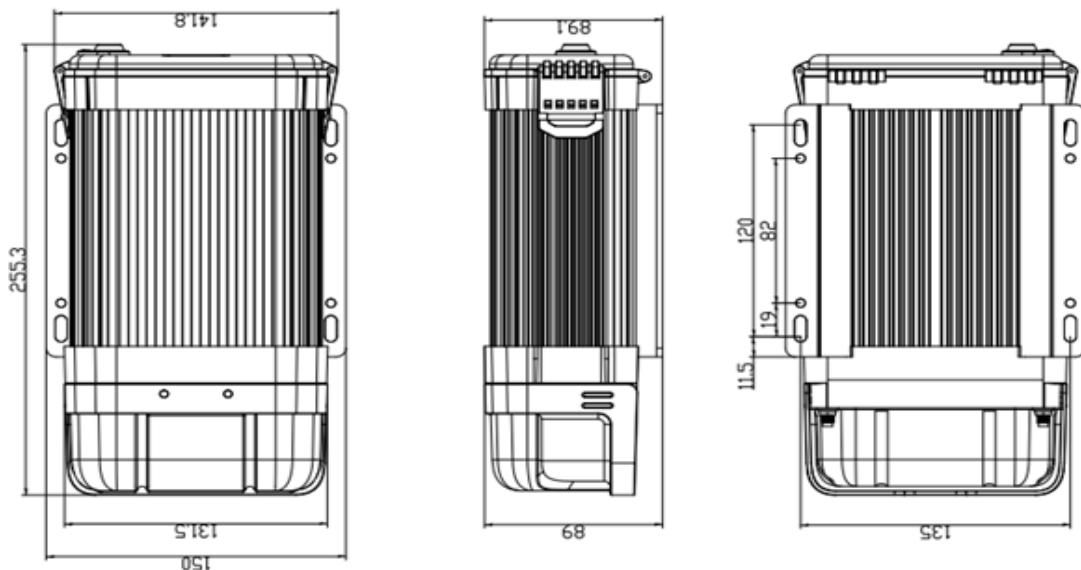

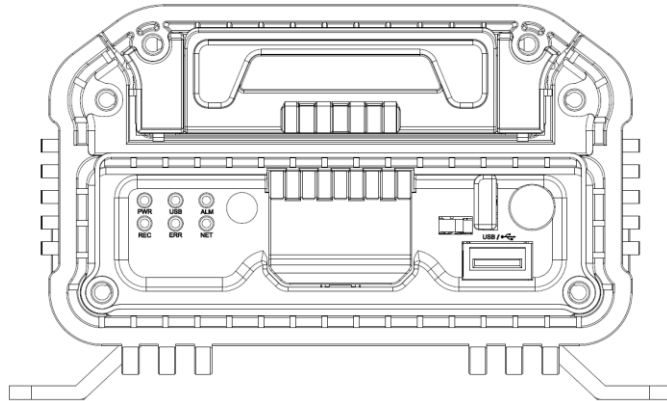

FRONT PANEL

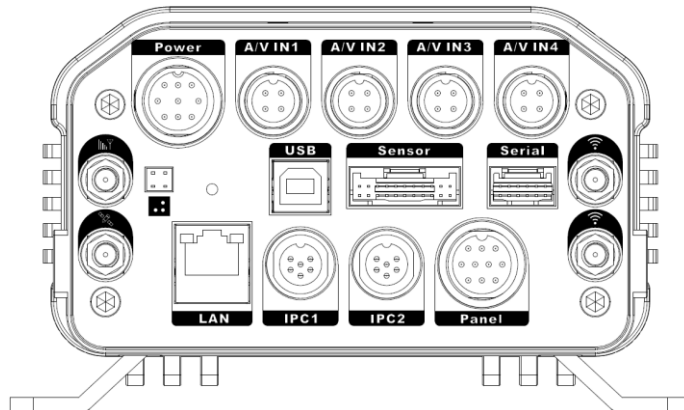

REAR PANEL



Serial No.	Print	Description
1	Power	DC 8-36 V Power Input
2	Sensor&Serial	The Interfaces of Serial Port and Switch
3	A/V IN1~4	Audio & Video Input 1-4
4	A/V OUT	Audio & Video Output
5	IPC	The Interface of PON Power Supply
6		GPS Antenna Interface
7		3G/4G/WIFI Antenna Interface

1.5. HARD DISK INSTALLATION

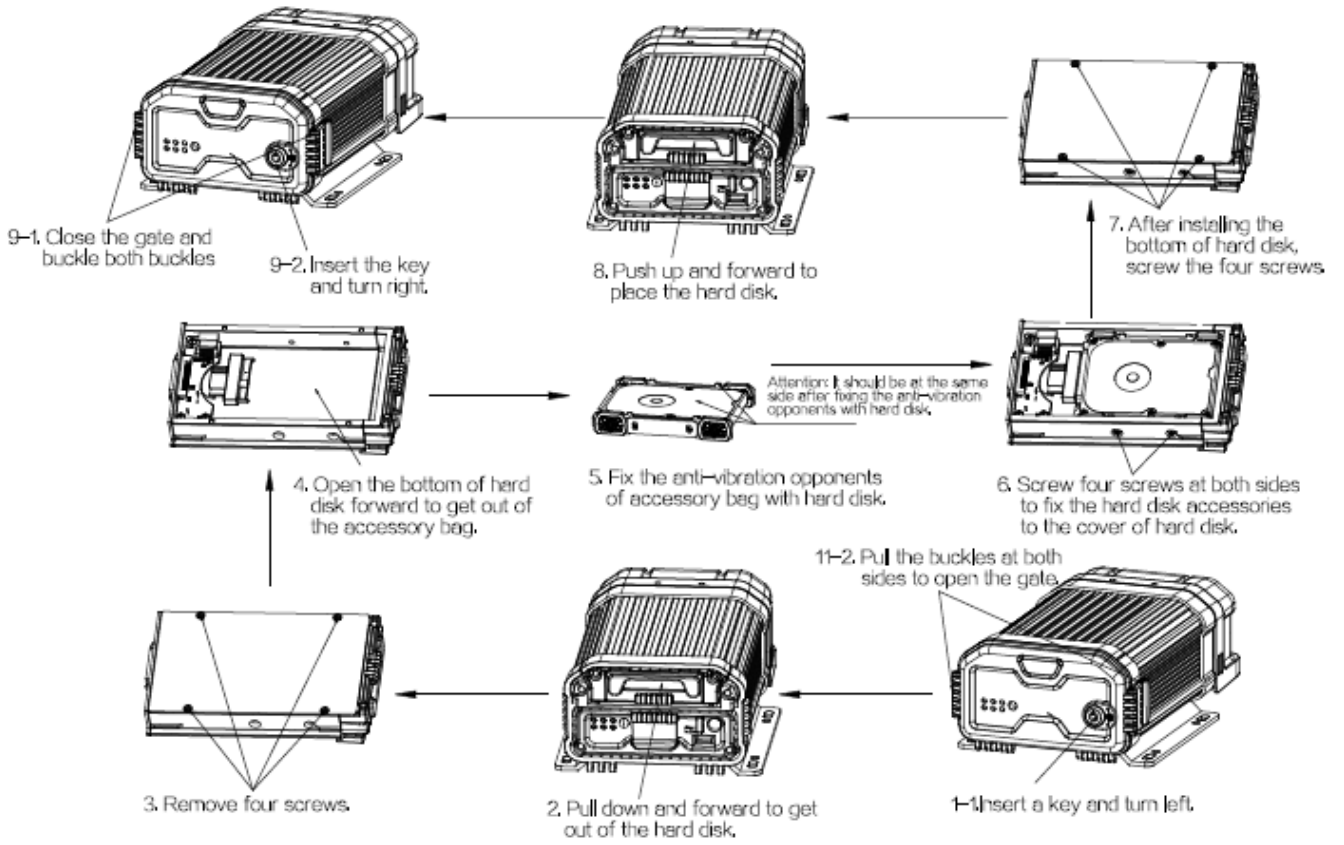

1.6. DEFINITION AND PICTURES OF EXTERNAL CABLES

ALARM CABLE DEFINITION

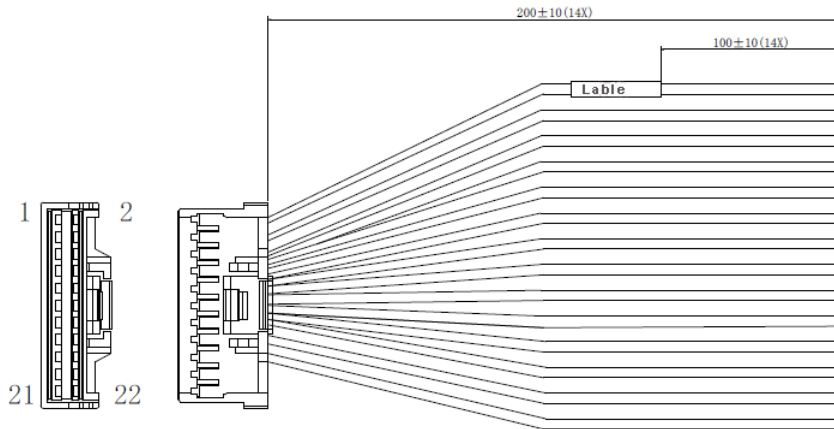

Diagram

501646-2200		
1	Green Cable	SENSOR IN1
3	Orange Cable	SENSOR IN2
5	Purple Cable	SENSOR IN3
7	Light Blue Cable	SENSOR IN4
2	Gray Cable	SENSOR IN5
4	Light Green Cable	SENSOR IN6
6	Pink Cable	SENSOR IN7
8	Yellow Cable	SENSOR IN8
9	Red Cable	+12V
10	Black Cable	GND
11	Blue&Black Cable	SENSOR-OUT1
13	Blue&Black Cable	SENSOR-OUT2
17	Blue Cable	SPEED IN
18	Black Cable	GND

SERIAL PORT DEFINITION

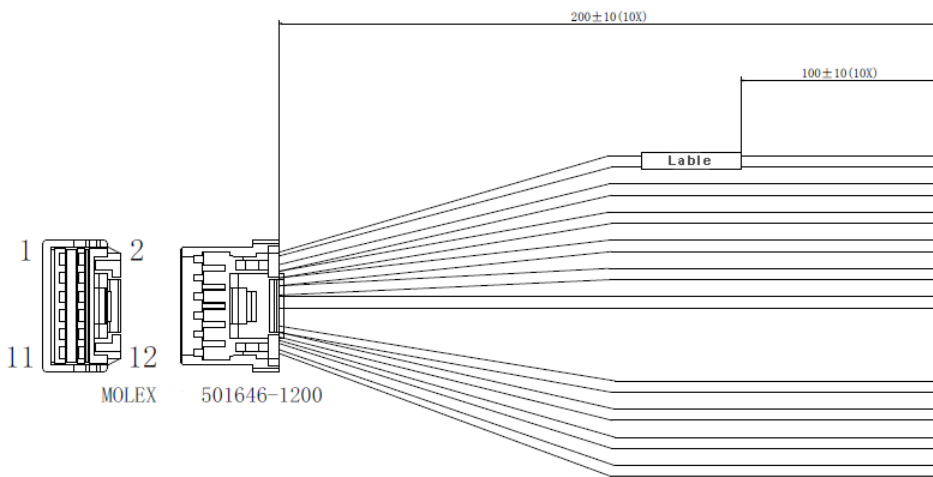

Diagram

501646-1200		
	White&Red Cable	232TX-1
1	Green&Red Cable	232RX-1
2	White&Black Cable	232TX-2
3	Green&Black Cable	232RX-2
4	Red Cable	+5V
5	Black Cable	GND
9	White&Blue Cable	485A-1
10	Green&Blue Cable	485B-1
11	White&Yellow Cable	485A-2
12	Green&Yellow Cable	485B-2

2. FREQUENTLY ASKED QUESTIONS

1) The system can't start?

Usually this problem results from the incorrect power connection. Please follow below steps to check the power connection:

1. Check the input power, whether the power wire is connected correctly, whether the ground wire is connected back to the battery, and whether the fuse on the power wire is in good condition.
2. Check whether the ACC signal wire input to the power is with voltage higher than 7 V.
3. Check whether the device key is closed.

2) The MDVR restarts uninterruptedly?

Please follow below steps to check it:

1. Check whether the voltage of MDVR is insufficient. If the voltage is less than the start-up voltage of the device, the device would always restart.
2. The problem in hard disk/SD card may cause the failure to start. Take off the storage part and check whether it is broken down.

3) The device can't record?

Usually this problem results from the storage disk or camera. Please follow below steps to check it:

1. Check whether the storage disk is installed, whether it is in good contact, and whether the disk can be read normally in computer.
2. Check whether the storage disk is formatted. The storage disk should be formatted before normally storing record files.
3. Check whether there is video signal input into the device from camera, and whether there is video/image on the screen.

4) There is no voice in record file?

Please follow below steps to check it:

1. Check whether there is an external pickup, or whether the camera features with the function of audio collection.
2. Access to Video Channel Settings, check if Audio is set on.
3. There must be video input into the channel for recording and it must record normally.

5) The GPS works abnormally?

Please follow below steps to check it:

1. Check whether the GPS antenna is installed correctly. There is a silk print logo on the GPS antenna holder behind the host device.
2. Check whether the antenna receiver is sheltered. It should not be covered by any stuff, which may cause it not to receive signals.
3. Environmental influence such as tree shades, being inside tunnel, driving near tall building or elevated roads, thunderstorms or other weather influence, etc. can also cause signal loss or receiving wrong signals.

6) The device can't shutdown in ignition switch mode?

Please follow below steps to check it:

1. Check if the ACC line connection mode is correct; and check whether there is voltage on ACC yellow line when the key is turned off.
2. If the device has been set with schedule recording, it can't shutdown if it is still during recording time of the task table.



ViPRO Mobile DVR – All MVR series

Installation Manual v1.1

This manual was complete and correct at the time of printing. The ongoing development of the products may mean that the content of the user guide can change without notice. The manual will be kept updating periodically, and software referred as well.

© 2014 ViPRO Corporation

Table of Content

NOTICE.....	3
Installation General Instruction	4
Part 1 MDVR Device Installation.....	5
1 Pre-Installation Preparation	5
1.1 Technical Requirement.....	5
1.2 Installer and Supervisor Qualification.....	5
1.3 Pre-installation Investigation and Installation Plan Making.....	5
1.4 Reference Installation Tool.....	6
2 MDVR Device Installations	7
2.1 The Hard Disk Installation	8
2.2 Power Connection.....	8
2.2.1 Power Wire Requirement.....	8
2.2.2 The Power Connection.....	8
2.3 MDVR Device installation.....	9
2.4 How to Choose and Install Cameras.....	11
2.5 Antenna (GPS/WIFI/3G) Connection	14
2.6 Monitor Installation.....	15
2.7 How to connect the I/O Sensors	16
2.8 How to Connect Alarm System.....	17
2.9 How to Deal with the Connection for Cables and Wire	19
Part 2 The Whole System Testing after Installation	19
1 MDVR Device Testing.....	20
1.1 Inspection before Power Connection	20
1.2 Trial Testing after the System Gets the Power	20
1.3 Accessories Testing.....	21
1.4 MDVR Recording and Network Testing	21
1.4.1 MDVR Recording Testing	21
1.4.2 I/O Sensor Testing.....	22
1.4.3 Vehicle Speed and Pulse Testing.....	22
1.4.4 Wireless Network Testing.....	23
1.4.5 Software Upgrade	24
1.4.6 Setup Machine Registration Information.....	25
1.4.7 Storage Format (HDD or SD Card).....	25
Appendix	26
Bus Application.....	26
The Table for Bandwidth and Frame Rate.	27

NOTICE

Before you install the MDVR system in the vehicle, please be familiar with this system and read this manual carefully.

Meanwhile the whole installation process must be guided by the professional persons.

1. MDVR is electronic recording and storage system which must be delivered very carefully.
2. Use only a regular 12-volt DC or 24-volt DC (3 ~ 5 Amps) certified power supply for installation in vehicles. The MDVR can support wide power range from 8v ~36v DC. Please follow the installation and operating instructions provided to ensure a steady and reliable installation. Handle all electric equipments and connections properly to avoid injuries.
3. Even though the recorder unit may not be turned on, live power exists in the mounting assembly and precautions should be taken to avoid shock or short circuit.
4. The MDVR installation and maintenance should be implemented by the person who is trained professionally.
5. Choose the right place to install the recorder unit. The space must be big enough for ventilation. No any other subjects around are allowed.
6. Install the MDVR in a dry location shielded from direct contact with excessive humidity and moisture, rain or other sources of liquid spills. Do not install on a recessed surface where liquids may accumulate or under surfaces where liquids may drip.
7. Do not handle the MDVR with wet hands, while standing in water, or while in contact with other sources of water or moisture that could create a shock hazard.
8. Install the MDVR out of direct sunlight and away from direct sources of heat, dust, vibration and high magnetic field
9. MDVR and accessories installation must be insulated with vehicle to avoid loop interference
10. Do not attach any external device (not recommended) to the recorder unit without specified or approved by Vendor.
11. Attach the MDVR ground cable to the vehicle correctly to complete the power circuit.
12. Do not mount the unit to a surface subject to excessive vibration.
13. Do not take out or change any module when the MDVR is power on.
14. Power supply must connect to the vehicle battery positive and negative polarity directly or UPS from vehicle. Any other indirect power connection is forbidden. In order to make sure the device and vehicle work fine, please add a fuse into the connection for protection.
15. Please do maintenance routine for MDVR and accessories to avoid any screw loose or bad video image.

Installation General Instruction

Before install the recorder system and accessories, the most important is to know the vehicle construction especially for power. Please check following:

- 1) Which MDVR model and accessories will be installed?
- 2) In which part of the vehicle can install the MDVR? How big the size is?
- 3) Cables and installation tools (for example: electric drill, screw driver, screws, multimeters etc...)
- 4) Manpower distribution
- 5) General concept for wiring
- 6) Draft the specific installation guide for specific vehicle

Rough Installation Steps as below:

Step 1: Preparation

Step 2: Installing Point Test

Step 3: Installing

Step 4: Testing

Step 5: Inspection

Step 6: Finish the installation

Step 7: Maintenance

Part 1 MDVR Device Installation

1. Pre-Installation Preparation

1.1 Technical Requirement

Be familiar with the MDVR device functions and application

Be familiar with the whole MDVR solution

Be familiar with the vehicle electrical circuit, vehicle structure and installation skills.

1.2 Installer and Supervisor Qualification

Supervisor Qualification and responsibility

1. He must be familiar with the installation requirements, the whole MDVR system (including MDVR device and the relative accessories and PC software).
2. Assign the task to the installers and guide them for the installation
3. Control the installation schedule, installation inspection to make sure that installation is correct and safe.

Installer Qualification:











1. He must be trained and qualified for installation
2. He must comply with safety rules and use the installation tools safely
3. He must be very familiar with the vehicle working principle and the internal electronic equipment

1.3 Pre-installation Investigation and Installation Plan Making

Before installation, the installer must do the investigation to know more for the installation environment including:

1. He must know the vehicle which will be installed MDVR in
2. The point for installation and how to protect the MDVR and accessories.
3. Camera and some other accessories installation
4. He should prepare the suitable cable (the material for the cable and the length for the cable) for MDVR installation.
5. All the commonly-used materials should be listed to make sure the installation go fast
6. Some other that is helpful for installation

1.4 Reference Installation Tool

Item	Name	Photo	Specification	Function	Remark
1	Electric Drill			Drill the holes	
2	Drill bit		12mm	To drill the hole in the vehicle to get the power cable out getting the power for the MDVR.	
3	Drill bit		2.8mm	To drill the hole for cameras, monitor, bracket etc.	
4	Philips Screwdriver			for screwing manually	
5	Digital Multimeter			for voltage testing and short-circuit	
6	Power cable and extension				
7	Wire Stripper			for cable splitting and connecting	
8	Ribbon				
9	Thread Forming			To fix the camera and monitor bracket	
10	Log Bolts			for fixing MDVR machine and protection box	
11	Insulating Tape			for wrapping up the wires	

12	Soldering Iron			for welding	
13	Tin Bar				
14	Diagonal Pliers			for cable connecting	
15	Crimping Pliers			for cable connecting	
16	Scissors			for shrinkable tube cut	
17	Heat Gun			for shrinkable tube encapsulation	
18	Glass Clue Gun			for hole sealing and fixation	

2. MDVR Device Installation

The basic Installation principal is:

1. All parts installation complies to the principal: same type vehicle, same installation point
2. Keep the vehicle clean and safe

The MDVR installation is the most part. Please make sure that the MDVR unit is fully and carefully tested before installation to guarantee

1) MDVR working environment

The installer must know that MDVR works in harsh environment everyday and they have high requirements for the environment and installer's skill.

- a) Anti-vibration: The MDVR device must be installed the place with week vibration (for example: behind the driver's seat). Installing the MDVR on the rear of the vehicle with strong vibration or closing to the engine is forbidden.
- b) Ventilation: The MDVR device must be far away for the heating source in the vehicle. The installation point should be ventilated.
- c) Waterproof and Moisture-proof: The device must be away from water or some other liquid source. If necessary the external protection device is recommended (lock box or installation bracket)

- d) Dustproof: The device must be installed on the point with little dust
- e) Installation points size: horizontal installing for MDVR device is recommend as it is easier for installation and maintenance. The installation point size must be big enough and the MDVR device cannot be surrounded with other subjects are it is not good for ventilation.
- f) Electric: The MDVR device must be far away from electromagnetism environment to avoid the strong interference.
- g) Wiring: The cables should be hidden to keep the vehicle clean

2) MDVR Protection

If the MDVR has to be installed in the harsh environment (with much dust and high moisture or easily to be damaged humanly), the lock box or installation bracket provided by manufacturer are recommended.

3) Installation

- a) The MDVR must be installed horizontally (especially for the hard disk unit must be installed this way)
- b) The MDVR and accessories must be fix firmly to avoid strong vibration
- c) The IR receiver and the LED should (on the front panel of the MDVR) be toward to the direction with easy operation

2.1 The Hard Disk Installation

Each MDVR is shipped with the hard disk installation manual. Please read it very carefully. The wrong installation will shorten the life of the hard disk.

2.2 Power Connection

2.2.1 Power Wire Requirement

Power wire material: according to the MDVR device maximum load, power cable should be 1.5mm-2.5mm diameter BVV cable or with protection tube to ensure the wires are not frizzled and damaged easily.

2.2.2 The Power Connection

The power supply is the basic and critical for MDVR device working. The connection and wiring is very rigid for installation.

- 1) The MDVR power must be provided by the battery of the vehicle. It must be connected with the positive and negative polarity of the battery directly (Below left diagram). Or the power connects the vehicle power control box (Below right diagram). Any other ways for connection are forbidden as this will cause the unstable power supply and affect MDVR working.

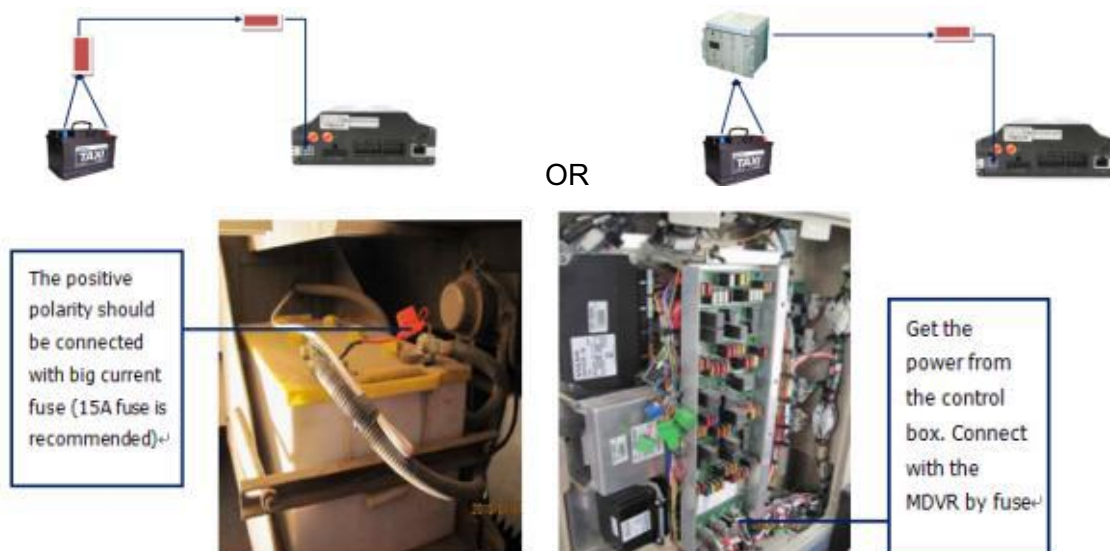

- 2) The power extension should be a little bit longer to leave some space for movement during the vehicle is running.
The external protection tube (fire resistant PVC bellow) are recommended. The diameter for the cable is required to be from 1.5mm to 2.5mm. Even for the bigger power consumption MDVR device or 12V vehicle with the long distance wiring requires that the cable diameter should be 2.0mm copper material inside.
- 3) The power cable wiring should be vertical with the other cable wiring to avoid the equidirectional interference.
- 4) Security setting: safety device (like fuse) must be added between the device and battery.

2.3 MDVR Device installation

The installation diagram

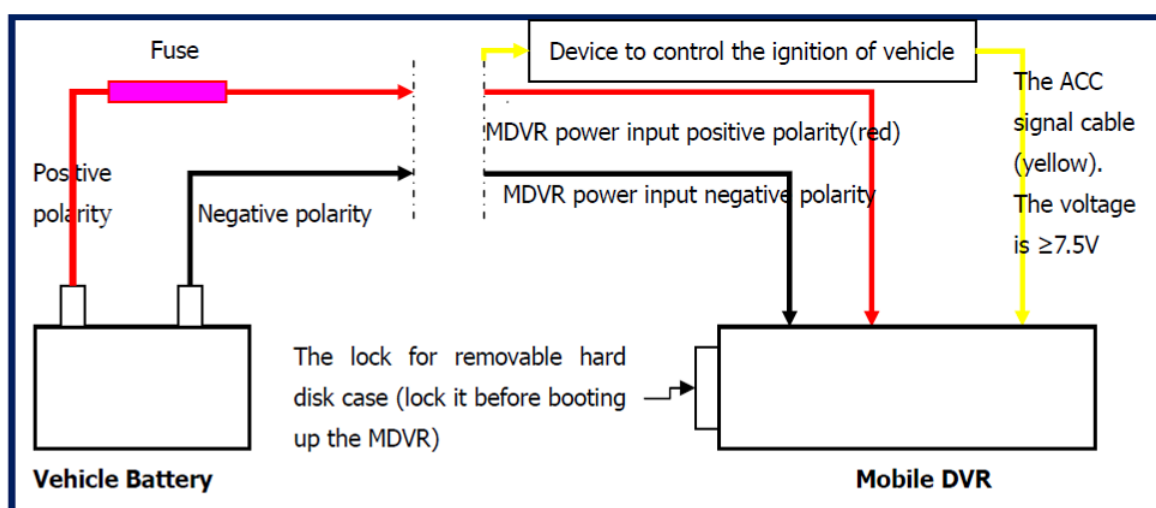

1. The MDVR cannot be installed on the vehicle floor directly. MDVR housing must be insulated with the body of the vehicle. External protection cap or box is necessary for waterproof and dustproof.
2. Horizontal installation is recommended by manufacturer
3. The LED light on the MDVR front panel should be outward for each checking the MDVR working status and receiving the IR signal.



4. Some tips for installation:

(1) 12V natural gas anti-interference isolation

When install the MDVR in 12V natural gas vehicles, the MDVR device must be insulated with the body of the vehicle. Get power for the MDVR from vehicle battery directly and make sure to install the power protector and security device between the MDVR device and battery.

(2) Pay attention to the polarity of electric power switch control (polarity test method: disconnect control switch, take a wire from battery negative polarity, test it with digital multimeter. Connect this wire by black pen on the multimeter, then connect vehicle body with red pen. If the circuit is working, this means that vehicle power switch control is positive. If not, it is negative. If the vehicle switch is negative, it is necessary to deal with the insulation between MDVR device and the accessories.

(3) It is very necessary for 12V battery-powered vehicles to deal with the insulation between the MDVR device and the accessories of MDVR.

5. ACC cable requirements

(1) ACC wire working principle

Actual wire: red is positive, black is negative, yellow is ignition signal.

The MDVR device does not work if yellow ignition signal wire is connected ground or nothing. Make sure ACC voltage is higher than 7.5V (Please test the voltage before connection) before booting up the MDVR system for ensuring normal operation.



(2) When the recording model for MDVR is timing recording, please make sure connect the yellow ignition signal wire with battery positive polarity.

(3) Switch power level value

Ignition	$\leq 6V$	Ignition OFF
Signal	$\geq 7.5V$	Ignition ON

6. All the wires connected to the rear panel of the MDVR should be wrapped together. The high frequency signal cables should be shield by protected device. The connection should be strong and firm. All lines cannot be

stretched. Protection solution are need for cable cut parts.

7. To fix the MDVR device well

2.4 How to Choose and Install Cameras

1) Camera Selection

There are 5 features should be considered for vehicle camera.

- (1) The monitored space for camera (Angle)
- (2) The size for the monitored objects
- (3) Focus
- (4) CCD size
- (5) Camera is required to have a good IC reset circuit to avoid the black screen during recording.

Except the above 5 features, there are some others requirements for camera working environment.

- (1) The camera should be small and not heavy.
- (2) Should support anti-vibration
- (3) Infrared light is required to monitor during the night or in some places with week light.
- (4) Waterproof and moistureproof

2) Camera Installation Regulation

- (1) The camera should be far away from heat source and electromagnetic interference in the vehicle.
- (2) The installation point should be safe avoiding camera damaged humanly.
- (3) How many cameras should be installed is depends on the vehicle size. Please make sure the camera
- (4) Angle is big enough to cover all parts of the vehicle (excluding some special application).
- (5) The camera should be fixed well to avoid any human moving effecting the monitoring image.
- (6) The camera should be installed in the point with good luminance. Otherwise the infrared light working too long time will affect the camera life.

3) Camera Installation Diagram

Usually required by bus operator or bus company, there are 4 cameras should be installed for one bus. These cameras are used to monitor driver, coin box, rear door, road and every parts in the vehicles. The infrared color camera is recommended.

- (1) Front camera: To monitor the driver, the driver must drive correctly and safely to avoid the accident.
- (2) The wide angle camera is recommended. If the angle is big enough, it can monitor the driver and the road forward together.
- (3) Camera for coin box: To check whether some passengers get on the bus without paying
- (4) Rear door camera: To check whether some passengers get on the bus without paying (as there is no coin box in some buses)
- (5) Rear camera: To monitor the whole vehicle inside for passenger behavior for example: thievery, fight)

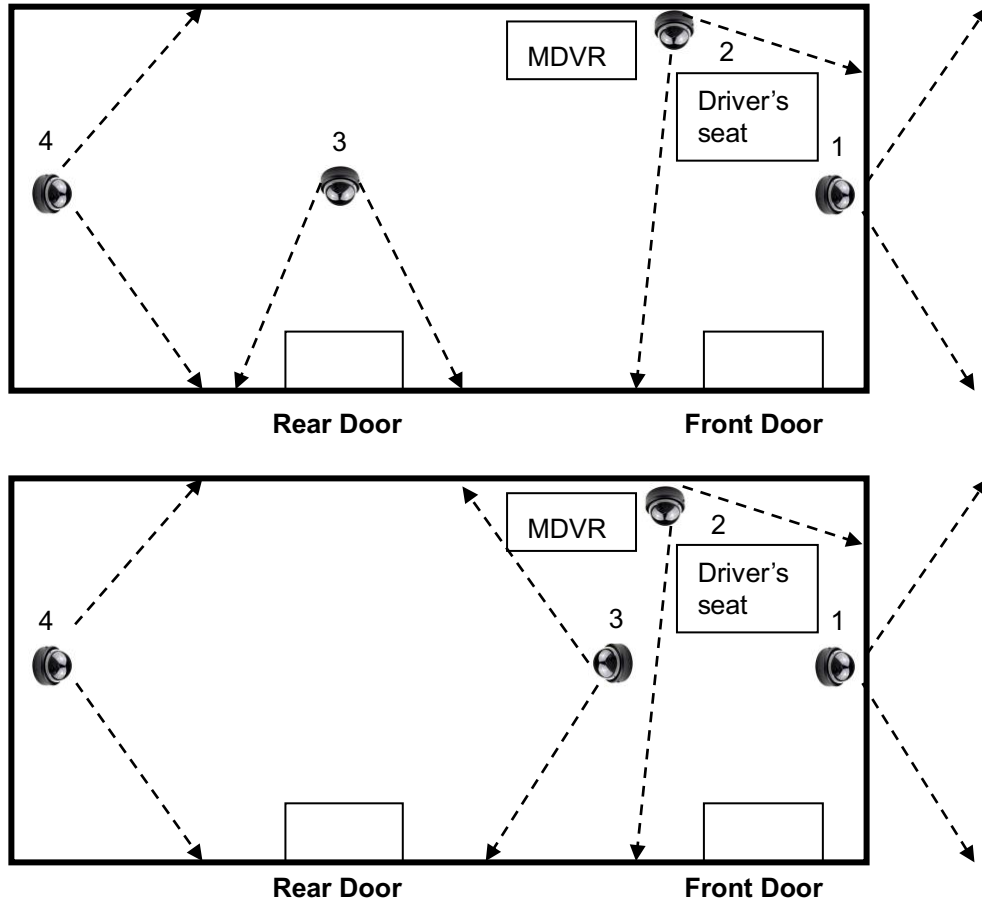

4) The Installation Photos for Reference

Mainly the installation point for camera is really depends on different vehicle and different application. Here please see some photos for reference.



The rear camera



For police car, taxi or some other vehicles, the camera installation point will be different. Here are some photos for reference.

For taxi installation



Install 2 cameras on the roof of the police car

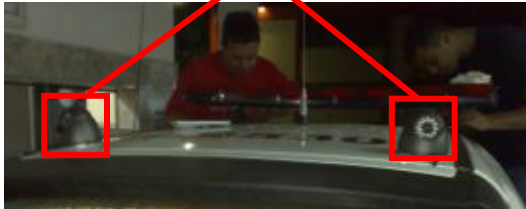

The PTZ for police car application

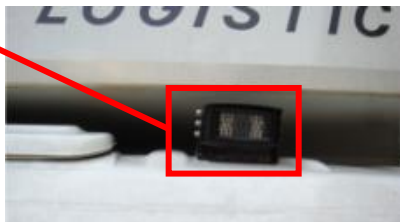

2.5 Antenna (GPS/WIFI/3G) Connection

For the products with WIFI, GPS, 3G functions, the antenna will be shipped with the MDVR together to customers.



Here are some tips for antenna connection and fixation:

- (1) The antenna is recommended to be installed on vehicle roof (drill the hole on the roof) to get the good signal.
- (2) The external protection cap is recommended for antenna to avoid human damage.
- (3) Each antenna cannot interfere mutually.
- (4) If the antenna cannot be installed outside of the vehicle (As some bus companies or bus operators do not agree to drill a hole on the vehicle roof. In this situation, the antenna should be fixed inside of the vehicle to guarantee the good signal.

1) How to Connect WIFI Antenna

Currently there main WIFI system includes:

- (1) 802.11b: Speed is 11M. Frequency is 2.4G HZ. This signal distance for this system is from 200 to 400 meters.
- (2) 802.11a: Speed is 54M. Frequency is 5G HZ
- (3) 802.11g: Speed is 54M and 11M optional. This system is compatible with 802.11b and 802.11a. The frequency is 2.4GHZ, But when this system is compatible with 802.11a, the frequency is 5GHZ.

2) The Photos for Reference



The WIFI antenna near dash mounted panel in bus

3) How to Connect GPS Antenna

GPS should be installed on the roof of vehicles for good reception of satellite signals. If drilling the hole on the vehicle roof is forbidden, then please try to get the GPS cable outside of the vehicle (please put the cable hidden)). The GPS antenna bottom is magnetic and can be stick to the metal on the roof of the vehicle. It must be fixed by glass cement and the antenna black side must be upward.

4) How to Connect 3G Antenna

Attach the antenna to the vehicle window or plastic shell, but not the metal as it will affect the communication signal.

5) General Connection Instruction

- (1) Choose right place for antenna for GPS/WIFI/3G installation. Generally the antenna are recommended to be installed in front part of vehicle roof (please drill one hole on the vehicle roof and installed the antenna outdoor) and fix them. Make sure put them in open air without any blocking.
- (2) Use a waterproof rubber stopper or glass cement or some other reliable ways to seal the hole for stretching the antenna out to ensure the tightness of roof.
- (3) An extra cap is needed for external antenna. Exposing parts should be waterproof and fire treatment.
- (4) Place antenna in tri-angle shape with 120 angle, 10cm distance between center point.
- (5) Fix antenna base with neutral silicone for fixing and waterproof.
- (6) On the cable of the antenna, there is one SMA connector, please connect it with the module firmly.



If drilling hole is not allowed by bus company or bus operator, then please install the antenna just inside of the vehicle



6) Installation Tips:

- (1) The WIFI antenna must be fixed by the glass cement and the WIFI antenna bottom plane must be parallel with the vehicle roof. Standing or side installation are not allowed.
- (2) GPS antenna should be installed in open air on top of vehicle, The bottom plane must be parallel with the vehicle roof and fixed by glass cement. Stand or side installation are not allowed. The black side must be upwards.
- (3) EVDO (CDMA2000)/HSDPA (WCDMA) antenna, stickled on glass or plastic shell but not metal as this will affect the network signal.

2.6 Monitor Installation

Monitor Installation depends on different requirement. It is recommended to install where is easy to by viewed by driver and can avoid sight reflection such as around rear-view mirror.



2.7 How to connect the I/O Sensors

The MDVR device can support 8 sensor inputs and 2 or 4 outputs (depends on different models. Some of the models can support 2 outputs only). The inputs are used to detect the driving behavior like panic button for emergency alarm, braking, turning left or right, open or close the door, reverse etc...

In MDVR GUI, you can setup different sensor inputs as following. You can define any or the sensor inputs to be different function. For example, if you define sensor 1 is for panic button please connect panic button with sensor 1 signal on the alarm box (the photo is below). Please just make sure you connect the sensor correctly with the alarm box.



SENSOR						
	EN	NAME	OSD	SET	ALARM	LOCK
S1	ON	PANIC	PB	LOW	ON	OFF
S2	OFF	F-DOOR	FD	LOW	OFF	OFF
S3	OFF	R-DOOR	RD	LOW	OFF	OFF
S4	OFF	BRAKE	BK	LOW	OFF	OFF
S5	ON	LEFT	LT	LOW	OFF	OFF
S6	OFF	RIGHT	RT	LOW	OFF	OFF
S7	OFF	RED WA	RW	LOW	OFF	OFF
S8	OFF	YEL WA	YW	LOW	OFF	OFF

NEXT PAGE SAVE EXIT

1) How to connect the signal for open/close the door

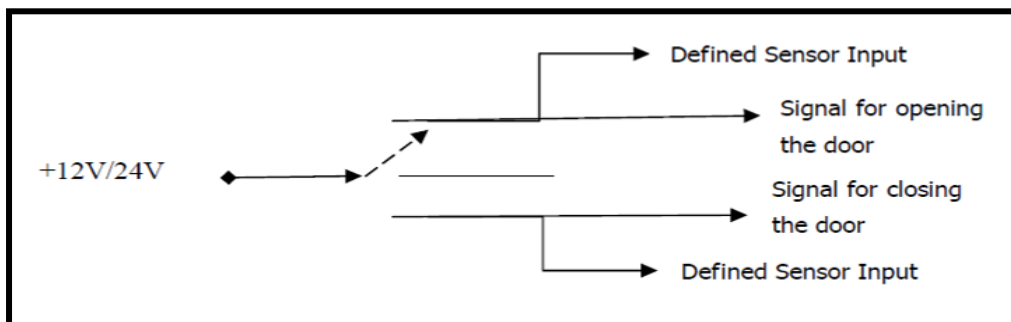

2) How to connect the signal for braking

When the driver stamps the brake vane, the MDVR device can detect the high power level. Otherwise it is low power level.

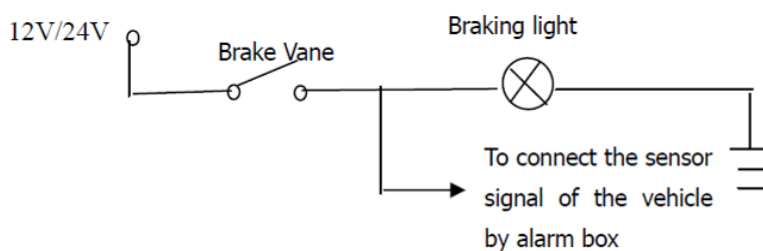

Alarm outputs are power level output. For powerful equipments, external replay is necessary. The following diagram is for how to wire the photoelectric alarm from alarm outputting.

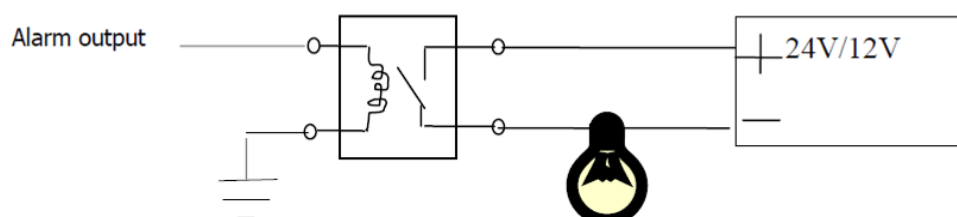

2.8 How to Connect Alarm System

Alarm system (we say panic button as well) is one of the MDVR I/O sensor input function. This function is used to deal with some emergency. For example if some accidents happens, the driver or the passengers can press the button to trigger the alarm video to centre server by 3G network.

The alarm system is very typical for bus application. There are 2 different panic button used for bus. One is for driver and another is for passenger.

1) Driver alarm system installation



Generally the alarm system for driver is installed close to him for easy operation. The signal from MDVR to front part driver panic button connected with 3*0.2 wires.

The installation steps are as bellow:

- (1) Drill a hole with 65mm length, 35mm width beside the seat of the driver (This size of the hole is depends on the size of the panic button)
- (2) Connect panic wire with connectors behind panic button.
- (3) Fix button with thread foaming.

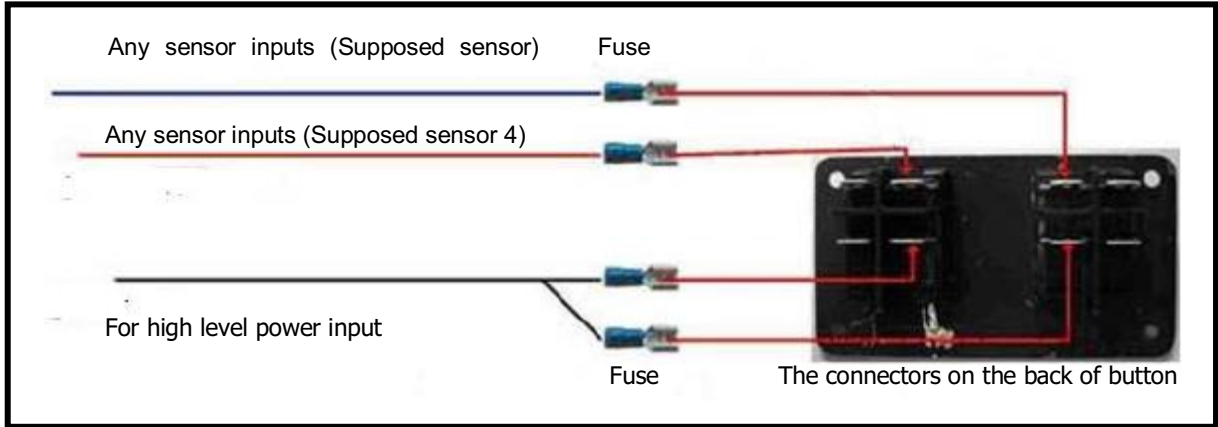

2) The Photos for Reference



3) Alarm System for Passengers

Signal wire of this alarm button is 4*0.2 wires. The wiring diagram as picture below:

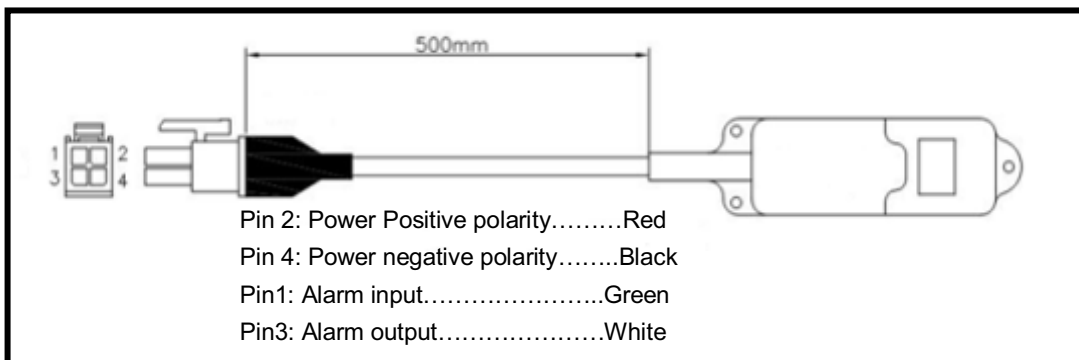

Generally the alarm system for passenger is installed near by the passenger and the wiring should go with the air-conditioner. Different vehicle has different internal environment. Every vehicle should have the suitable installation method. Here introduce the installation steps for the vehicle with air-conditioner:

- (1) Drill the hole close the channel for air conditioner
- (2) Pull the wire through air conditioner channel and take it out from the hotel and connect with alarm Box
- (3) Fix the button with thread forming between 2 windows in the vehicle



2.9 How to Deal with the Connection for Cables and Wire

1) Cold Pressing Connection

- (1) There are 3 different standards for wire connector: CHS-Φ3、5、8. according to the actual demand.
- (2) All the cut cables must be connected by the wire connector
- (3) Please use the wire stripper (model: HS-I01/0.5~10mm) for connection.
- (4) The cold pressing process is striping the cable cover (10mm~15mm), connecting all the copper wire together, cutting off the raw edge and put them into the suitable wire connector and then pressing connect by the wire stripper.
- (5) After the compression, please wrap the cables together by ribbon.

2) Welding

- (1) If the wire of video cable or complex cable is too thin to be cold pressed, please try to weld.
- (2) The power cable or others cables can not be cold pressed, please try to weld too. Wire wrap connection is not allowed.
- (3) After the welding, binding the cable with the ribbon.

Part 2 The Whole System Testing after Installation

1. MDVR Device Testing

1.1 Inspection before Power Connection

After all the equipments are installed, please follow the steps to check before power supply for MDVR:

1) Wiring Inspection

- (1) Cable wiring should be cross-vertical strokes, orderly to keep the vehicle clean and safe
- (2) Wiring for power cable, extension cable, ground wire and digital wire should be in orderly.
- (3) Keep 90 degree angle if cables cross is necessary.
- (4) Suitable ribbon should be used in binding with consistent method and equal spacing; redundant ribbon should be cut off and not harm for hand.
- (5) Ribbon should be not too tight to injury the cable. The cable should not touch the sharp objects, rubber protector is necessary for the holes
- (6) All cable should be with Cabling Rack, no jump wiring is allowed.

2) MDVR Device inspection

- (1) Check the MDVR device is fixed well or not. Try to move the MDVR and check whether it is loose.
- (2) Check the device power connection is correct or not. Connect the MDVR ground cable with vehicle directly is not allowed.
- (3) Check whether the hard disk or SD card installation is correct or not?
- (4) Inspect all connection cables and connectors.

3) Electrical Equipment Inspection

After the inspection for MDVR machine, please confirm the each connector as following:

- (1) Checking the voltage for power connector is from 8V to 36V, higher or lower voltage will bring damage for the MDVR machine.
- (2) Checking all kinds of antennas are well connected as photo showed.
- (3) Check video outputting connector.
- (4) Check the camera, no short-circuit and electrical ground phenomenon.

4) System Inspection and testing

- (1) Check the cable connection is strong and firm.
- (2) Check the connection of power and whether the fuse can work fine.

1.2 Trial Testing after the System Gets the Power

- (1) After all the checking in item 1.1, please try to connect the power for the system.
- (2) After the MDVR gets power, please check the LED lights on the front panel of the MDVR.
- (3) Does the relative LED is flashing or not. Does some LED shows error information.
- (4) Check the image from the monitor
- (5) Check the MDVR output voltage is normal or not (12V,5A)
- (6) Check the firmware version, communication module and GPS module if the signal is strong or not.

- (7) HDD format. After formatting, the MDVR system will reboot up. After that, please check the REC LED on the front panel of the MDVR to ensure that MDVR can record. Then please enter the MDVR GUI for configuration
- (8) **The last step is for** Ignition test. Checking whether the machine will restart or not . If the MDVR will reboot up continuously, please re-check the cables connection and load capacity of the system.

1.3 Accessories Testing

1) Camera testing

After the MDVR gets power and works fine. Please try to test the camera as following:

- (1) Checking the video interference exists or not firstly.
- (2) Angle and focus adjustment and turning the Lens circle to adjust the focal length for a clearer image according to the scope of monitoring.
- (3) For the night vision camera, please check its infrared light is on or not in dark environment, off in bright environment. (Please try to manually cover and release the CCD on the camera lens for testing)
- (4) Recording the video and playback locally to check the image quality. If the video image is not good enough please try to change another camera.

2) Monitor Testing

Please Set up suitable brightness and contrast to check the monitor working status including full screen, image quality or or interference. Meanwhile Please avoid the reflect light to the driver's view.

1.4 MDVR Recording and Network Testing

1.4.1 MDVR Recording Testing

- a) Ignition recording: Active the ignition recording function and check whether MDVR can record as scheduled. In a given time(10 minutes), shut down and check the machine off or not.(for post recording of 1-300 mins in Ignition video, it is better to test 1 min post recording. When the working time no more than 10 mins, the machine will delay 5min to shut down)
- b) Time recording: setting up the time like 10mins, please check whether the MDVR machine can boot up and start recording in a given time and can turn off and stop recording after 10 minutes.
- c) Ignition recording and time shut down: Setting a shut down time, ignite the machine to check the machine shut down when time is up. Checking the video file.
- d) Alarm Video. Starting video when trigger from internal factor and external factors, like door- open alarm video, when the vehicle door is open, the machine will start to video when receiving the door-open signal.

Diagram for power connection to video machine from Ignition

For the details please check the MDVR GUI manual.

1.4.2 I/O Sensor Testing

Please enter into the MDVR GUI and select the function "Sensor" (Setup→Event→Sensor). Select "ON" or "OFF" for enable option. Define the name according to sensor connected.

SENSOR						
	ENABLE	NAME	OSD	SET	ALARM	LOCK
S1	ON	Brake	COM	HIGH	ON	OFF
S2	OFF	Turn Left	BK	LOW	OFF	OFF
S3	OFF	Panic Button	LT	LOW	OFF	OFF
S4	OFF	Turn right	RT	LOW	OFF	OFF
S5	OFF		FD	LOW	OFF	OFF
S6	OFF		FD	LOW	OFF	OFF
S7	OFF		FD	LOW	OFF	OFF
S8	OFF	F-DOOR	FD	LOW	OFF	OFF

NEXT PAGE SAVE EXIT

EN: Enable, to active this function

NAME: Press ENTER on the Name field to display the soft keyboard. Enter the text name to identify the source of each Sensor connected to the unit.

OSD: Input the numbers and Characters, they will be embedded into the alarm video files when alarms happen, and it will also display in live view, Please press【Enter】 into the soft keyboard. The label also identifies the type of event when doing a quick search using **EVENT SEARCH** option.

SET: LOW (normal close) means high to low trigger the alarm. When the sensor input is decreasing from 12V or 24V to 0V, the sensor alarm is triggered.

HIGH (normal open) means low to high trigger the alarm. When the sensor input is from 0V increasing to 12V or 24V, the sensor alarm is triggered.

ALARM: Press ENTER to select between OFF or ON:

ON means when sensor triggered, alarm LED will flashing, until re-login the system with account, the flashing will disappear, also, if the security set as OFF, I.E no need enter password to re-login, just pressing ENTER can disappear the flashing.

LOG: Press ENTER to select YES/NO to enable or disable the input sensor to put as event log file, the EVENT LOG is recorded in EVENT search file e.g.: If set as ON, using **EVENT SEARCH** option even sensor triggered, there is event file on this menu.

LOCK: To enable the event does not erase during the over-write process of hard disk;

Get the video files embed the I/O sensor information and playback on the PC software. Check whether the data is correct.

If the MDVR system supports wireless transmission, please check the alarm report to CMS as well.

1.4.3 Vehicle Speed and Pulse Testing

Please connect the SPEED-A on the alarm box with the vehicle speed signal cable and the GND on the alarm box to the GND of the vehicle sensor.

Speed adjustment function: input the speed value to SPD before adjustment. P/S value will be obtained automatically.

When vehicle speed is stable (last half minute) and achieve to SPD speed, Please press "CHECK", P/S will obtain the pulse

value automatically. Directly input P/S value for the same model vehicle.

For example:

Please input 40MP/H for SPD, when vehicle speed last 40MP/H for half minute. Please press the “CHECK”, A value will appear automatically from P/S. For example:20, the rate confirmed between Pulse value and driving speed of sensor.

Direct inputting SPD for the same model vehicle, no more adjustment.

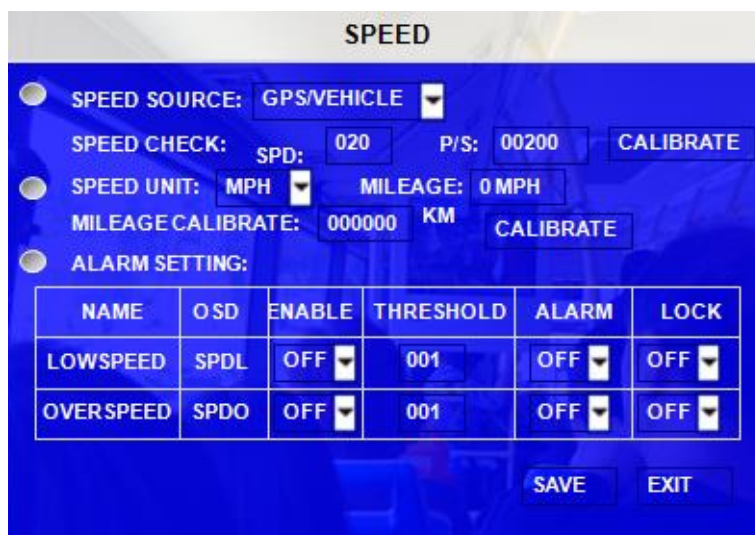

1.4.4 Wireless Network Testing

When the MDVR is in the QUAD view interface, please press “Enter” Key on the remote control entering into the OSD to check whether the wireless module is working fine or not.



If you cannot find out the GPS and network information here, please check following:

- 1) Whether the antenna connection is correct
- 2) Whether you setup the right parameter for network
- 3) The SIM card inserting is correct or not
- 4) Does the SIM card support huge data transfer (Note: Some of the SIM card are just used for cell phone service, not for data transmission)
- 5)

1) GPS function setting

Please check the GPS LED on the front panel of the MDVR. Green means that it works fine. If it is not green, please enter into the system information menu to check the GPS connection and OSD for GPS signal.



Time checking test: In MDVR menu Data/Time option, to select the GPS sync time and then select the time zone to check whether it works fine.



GPS location debugging: Enter into the OSD interface to check the longitude and latitude.

2) Internet function Testing (local IP,WIFI,3G)

For the details please check the CMS and 3G connection manual.

1.4.5 Software Upgrade

1. Create a folder named '**dvrupgrade**' in the thumb drive and then copy the firmware upgrade file to this folder.
2. Insert the thumb drive into the USB port on the front panel of MDVR.
3. Select **SETUP>>>SYSTEM>>>UPGRADE** to get to the upgrade interface and then press **【UPGRADE】**, MDVR will upgrade the firmware automatically.
4. All LEDs will light up or flash during firmware upgrade.
5. It will restart automatically after successful upgrade.



Please do not disconnect the power supply for MDVR or remove the thumb drive during firmware upgrade.

To ensure the firmware upgrade is completely successful, please check if the firmware has the latest version after MDVR is being restarted.

1.4.6 Setup Machine Registration Information

Please check the details in the MDVR GUI manual

1.4.7 Storage Format (HDD or SD Card)

Format the storage before using or replacing the storage. Please check the details from the DVR GUI manual.

Appendix

Bus Application

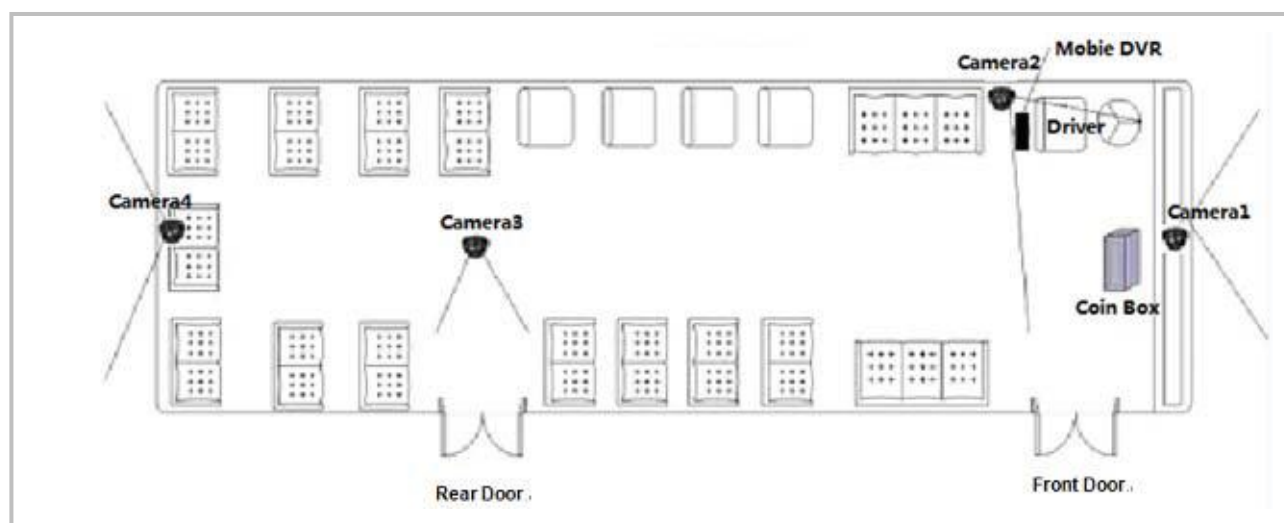
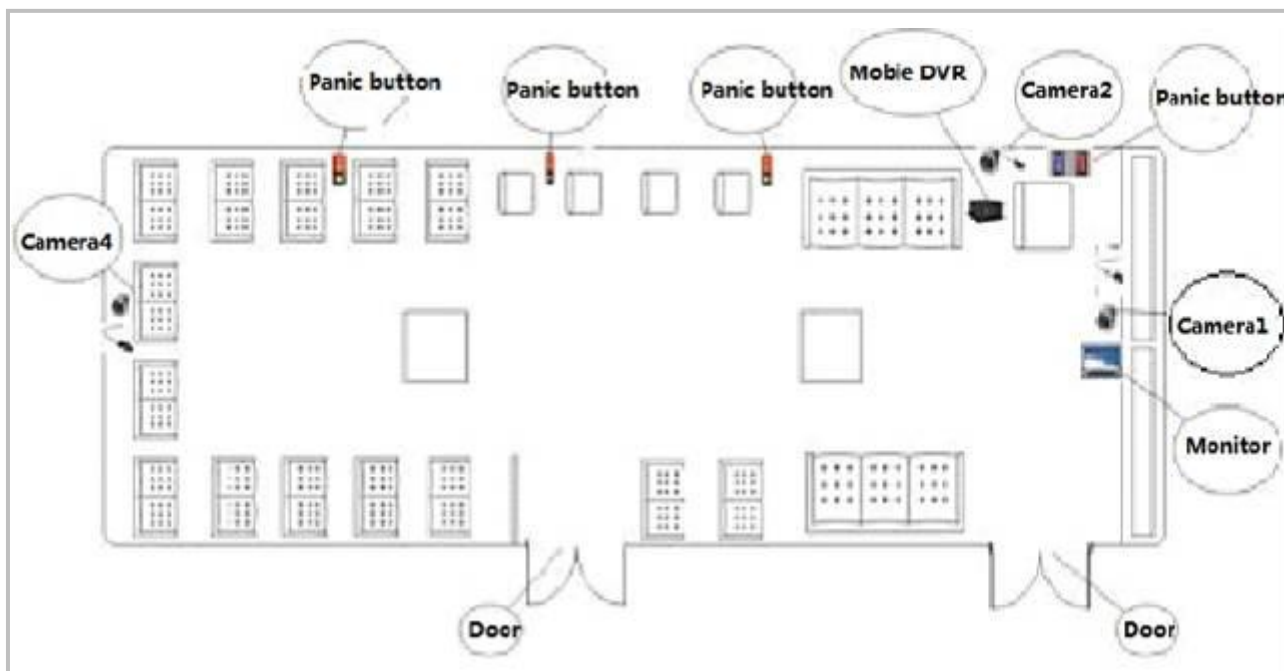

The Table for Bandwidth and Frame Rate

Bit Rate (Kbps)	GOP Size		Frame Rate (Frms/S)	
	Default: P(N)	Range: P(N)	Default	Range
20	50(60)	25-100(30-120)	1	1-5
50	50(60)	25-100(30-120)	2	1-5
80	50(60)	25-100(30-120)	3	2-5
110	50(60)	25-100(30-120)	4	3-8
140	50(60)	25-100(30-120)	5	5-11
170	50(60)	25-100(30-120)	6	5-12
200	50(60)	25-100(30-120)	7	5-12
230	50(60)	25-100(30-120)	8	6-13
260	50(60)	25-100(30-120)	9	7-13
290	50(60)	25-100(30-120)	10	7-14
320	50(60)	25-100(30-120)	11	7-15
350	50(60)	25-100(30-120)	12	7-15
380	50(60)	25-100(30-120)	13	9-15
410	50(60)	25-100(30-120)	14	9-16
440	50(60)	25-100(30-120)	15	10-18
470	50(60)	25-100(30-120)	16	11-20
500	50(60)	25-100(30-120)	18	15-Full frame rate