

COMPLEMENTARY SILICON POWER DARLINGTON TRANSISTORS

■ SGS-THOMSON PREFERRED SALESTYPES

DESCRIPTION

The MJ2501 is a silicon epitaxial-base PNP power transistors in monolithic Darlingtion configuration and are mounted in Jedec TO-3 metal case. They are intended for use in power linear and switching applications.

The complementary NPN type is the MJ3001.

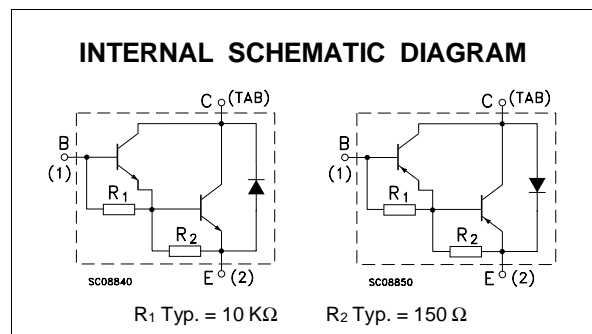
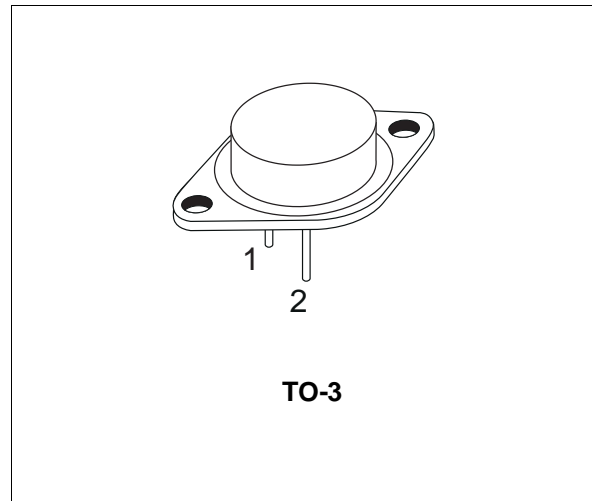

ABSOLUTE MAXIMUM RATINGS

Symbol	Parameter	Value		Unit
		PNP	MJ2501	
		NPN	MJ3001	
V_{CBO}	Collector-base Voltage ($I_E = 0$)		80	V
V_{CEO}	Collector-emitter Voltage ($I_B = 0$)		80	V
V_{EBO}	Emitter-base Voltage ($I_C = 0$)		5	V
I_C	Collector Current		10	A
I_B	Base Current		0.2	A
P_{tot}	Total Dissipation at $T_c \leq 25^\circ\text{C}$		150	W
T_{stg}	Storage Temperature		-65 to 200	$^\circ\text{C}$
T_j	Max. Operating Junction Temperature		200	$^\circ\text{C}$

For PNP types voltage and current values are negative.

THERMAL DATA

$R_{thj-case}$	Thermal Resistance Junction-case	Max	1.17	$^{\circ}C/W$
----------------	----------------------------------	-----	------	---------------

ELECTRICAL CHARACTERISTICS ($T_{case} = 25^{\circ}C$ unless otherwise specified)

Symbol	Parameter	Test Conditions	Min.	Typ.	Max.	Unit
I_{CER}	Collector Cut-off Current ($R_{BE} = 1\text{ K}\Omega$)	$V_{CE} = 80\text{ V}$ $T_{case} = 150^{\circ}C$			1	mA
		$V_{CE} = 80\text{ V}$			5	mA
I_{CEO}	Collector Cut-off Current ($I_B = 0$)	$V_{CE} = 30\text{ V}$ $V_{CE} = 40\text{ V}$			1 1	mA mA
I_{EBO}	Emitter Cut-off Current ($I_C = 0$)	$V_{EB} = 5\text{ V}$			2	mA
$V_{CEO(sus)*}$	Collector-Emitter Sustaining Voltage ($I_B = 0$)	$I_C = 100\text{ mA}$	80			V
$V_{CE(sat)*}$	Collector-emitter Saturation Voltage	$I_C = 5\text{ A}$ $I_B = 20\text{ mA}$			2	V
		$I_C = 10\text{ A}$ $I_B = 50\text{ mA}$			4	V
V_{BE*}	Base-emitter Voltage	$I_C = 5\text{ A}$ $V_{CE} = 3\text{ V}$			3	V
h_{FE*}	DC Current Gain	$I_C = 5\text{ A}$ $V_{CE} = 3\text{ V}$	1000			

* Pulsed: Pulse duration = 300 μs , duty cycle 1.5 %
For PNP types voltage and current values are negative.

TO-3 MECHANICAL DATA

DIM.	mm			inch		
	MIN.	TYP.	MAX.	MIN.	TYP.	MAX.
A	11.00		13.10	0.433		0.516
B	0.97		1.15	0.038		0.045
C	1.50		1.65	0.059		0.065
D	8.32		8.92	0.327		0.351
E	19.00		20.00	0.748		0.787
G	10.70		11.10	0.421		0.437
N	16.50		17.20	0.649		0.677
P	25.00		26.00	0.984		1.023
R	4.00		4.09	0.157		0.161
U	38.50		39.30	1.515		1.547
V	30.00		30.30	1.187		1.193

