



# Quad Single Supply Comparators

These comparators are designed for use in level detection, low-level sensing and memory applications in consumer automotive and industrial electronic applications.

- Single or Split Supply Operation
- Low Input Bias Current: 25 nA (Typ)
- Low Input Offset Current:  $\pm 5.0$  nA (Typ)
- Low Input Offset Voltage:  $\pm 1.0$  mV (Typ) LM139A Series
- Input Common Mode Voltage Range to Gnd
- Low Output Saturation Voltage: 130 mV (Typ) @ 4.0 mA
- TTL and CMOS Compatible
- ESD Clamps on the Inputs Increase Reliability without Affecting Device Operation

## MAXIMUM RATINGS

| Rating   | Symbol     | Value  | Unit                      |
|--|------------|--|---------------------------|
| Power Supply Voltage<br>LM239, A/LM339A/LM2901, V<br>MC3302  | $V_{CC}$   | +36 or $\pm 18$<br>+30 or $\pm 15$                                 | Vdc                       |
| Input Differential Voltage Range<br>LM239, A/LM339A/LM2901, V<br>MC3302                            | $V_{IDR}$  | 36<br>30   | Vdc                       |
| Input Common Mode Voltage Range  | $V_{ICMR}$ | -0.3 to $V_{CC}$   | Vdc                       |
| Output Short Circuit to Ground (Note 1)  | $I_{SC}$   | Continuous   |                           |
| Power Dissipation @ $T_A = 25^\circ\text{C}$<br>Plastic Package<br>Derate above $25^\circ\text{C}$ | $P_D$      | 1.0<br>8.0   | W<br>mW/ $^\circ\text{C}$ |
| Junction Temperature   | $T_J$      | 150  | $^\circ\text{C}$          |
| Operating Ambient Temperature Range<br>LM239, A<br>MC3302<br>LM2901<br>LM2901V<br>LM339, A         | $T_A$      | -25 to +85<br>-40 to +85<br>-40 to +105<br>-40 to +125<br>0 to +70 | $^\circ\text{C}$          |
| Storage Temperature Range  | $T_{stg}$  | -65 to +150  | $^\circ\text{C}$          |

**NOTE:** 1. The maximum output current may be as high as 20 mA, independent of the magnitude of  $V_{CC}$ . Output short circuits to  $V_{CC}$  can cause excessive heating and eventual destruction.

**Figure 1. Circuit Schematic**

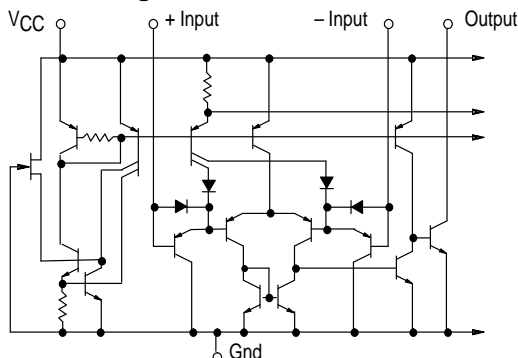

**NOTE:** Diagram shown is for 1 comparator.

# LM339, LM339A, LM239, LM239A, LM2901, M2901V, MC3302

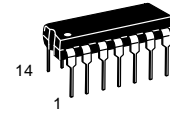

**N, P SUFFIX**  
PLASTIC PACKAGE  
CASE 646

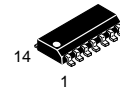

**D SUFFIX**  
PLASTIC PACKAGE  
CASE 751A  
(SO-14)

## PIN CONNECTIONS

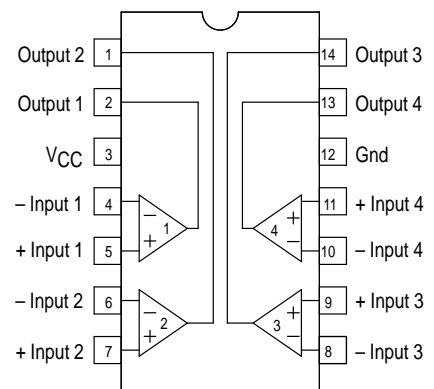

(Top View)

## ORDERING INFORMATION

| Device                   | Operating Temperature Range               | Package              |
|--------------------------|---|----------------------|
| LM239D,AD<br>LM239N,AN   | $T_A = 25^\circ$ to $+85^\circ\text{C}$   | SO-14<br>Plastic DIP |
| LM339D, AD<br>LM339N, AN | $T_A = 0^\circ$ to $+70^\circ\text{C}$    | SO-14<br>Plastic DIP |
| LM2901D<br>LM2901N       | $T_A = -40^\circ$ to $+105^\circ\text{C}$ | SO-14<br>Plastic DIP |
| LM2901VD<br>LM2901VN     | $T_A = -40^\circ$ to $+125^\circ\text{C}$ | SO-14<br>Plastic DIP |
| MC3302P                  | $T_A = -40^\circ$ to $+85^\circ\text{C}$  | Plastic DIP          |

# LM339, LM339A, LM239, LM239A, LM2901, M2901V, MC3302

## ELECTRICAL CHARACTERISTICS (V<sub>CC</sub> = +5.0 Vdc, T<sub>A</sub> = +25°C, unless otherwise noted)

| Characteristic   | Symbol            | LM239A/339A |            |                         | LM239/339 |            |                         | LM2901/2901V |            |                         | MC3302 |            |                         | Unit |
|--|-------------------|-------------|------------|-------------------------|-----------|------------|-------------------------|--------------|------------|-------------------------|--------|------------|-------------------------|------|
|  |                   | Min         | Typ        | Max                     | Min       | Typ        | Max                     | Min          | Typ        | Max                     | Min    | Typ        | Max                     |      |
| Input Offset Voltage (Note 4)  | V <sub>IO</sub>   | -           | ±1.0       | ±2.0                    | -         | ±2.0       | ±5.0                    | -            | ±2.0       | ±7.0                    | -      | ±3.0       | ±20                     | mVdc |
| Input Bias Current (Notes 4, 5)<br>(Output in Analog Range)  | I <sub>IB</sub>   | -           | 25         | 250                     | -         | 25         | 250                     | -            | 25         | 250                     | -      | 25         | 500                     | nA   |
| Input Offset Current (Note 4)  | I <sub>IO</sub>   | -           | ±5.0       | ±50                     | -         | ±5.0       | ±50                     | -            | ±5.0       | ±50                     | -      | ±3.0       | ±100                    | nA   |
| Input Common Mode Voltage Range  | V <sub>ICMR</sub> | 0           | -          | V <sub>CC</sub><br>-1.5 | 0         | -          | V <sub>CC</sub><br>-1.5 | 0            | -          | V <sub>CC</sub><br>-1.5 | 0      | -          | V <sub>CC</sub><br>-1.5 | V    |
| Supply Current<br>R <sub>L</sub> = ∞ (For All Comparators)<br>R <sub>L</sub> = ∞, V <sub>CC</sub> = 30 Vdc   | I <sub>CC</sub>   | -           | 0.8<br>1.0 | 2.0<br>2.5              | -         | 0.8<br>1.0 | 2.0<br>2.5              | -            | 0.8<br>1.0 | 2.0<br>2.5              | -      | 0.8<br>1.0 | 2.0<br>2.5              | mA   |
| Voltage Gain<br>R <sub>L</sub> ≥ 15 kΩ, V <sub>CC</sub> = 15 Vdc   | A <sub>VOL</sub>  | 50          | 200        | -                       | 50        | 200        | -                       | 25           | 100        | -                       | 25     | 100        | -                       | V/mV |
| Large Signal Response Time<br>V <sub>I</sub> = TTL Logic Swing,<br>V <sub>ref</sub> = 1.4 Vdc, V <sub>RL</sub> = 5.0 Vdc,<br>R <sub>L</sub> = 5.1 kΩ | -                 | -           | 300        | -                       | -         | 300        | -                       | -            | 300        | -                       | -      | 300        | -                       | ns   |
| Response Time (Note 6)<br>V <sub>RL</sub> = 5.0 Vdc, R <sub>L</sub> = 5.1 kΩ   | -                 | -           | 1.3        | -                       | -         | 1.3        | -                       | -            | 1.3        | -                       | -      | 1.3        | -                       | μs   |
| Output Sink Current<br>V <sub>I</sub> (-) ≥ +1.0 Vdc, V <sub>I</sub> (+) = 0,<br>V <sub>O</sub> ≤ 1.5 Vdc  | I <sub>Sink</sub> | 6.0         | 16         | -                       | 6.0       | 16         | -                       | 6.0          | 16         | -                       | 6.0    | 16         | -                       | mA   |
| Saturation Voltage<br>V <sub>I</sub> (-) ≥ +1.0 Vdc, V <sub>I</sub> (+) = 0,<br>I <sub>sink</sub> ≤ 4.0 mA   | V <sub>sat</sub>  | -           | 130        | 400                     | -         | 130        | 400                     | -            | 130        | 400                     | -      | 130        | 500                     | mV   |
| Output Leakage Current<br>V <sub>I</sub> (+) ≥ +1.0 Vdc, V <sub>I</sub> (-) = 0,<br>V <sub>O</sub> = +5.0 Vdc  | I <sub>OL</sub>   | -           | 0.1        | -                       | -         | 0.1        | -                       | -            | 0.1        | -                       | -      | 0.1        | -                       | nA   |

## PERFORMANCE CHARACTERISTICS (V<sub>CC</sub> = +5.0 Vdc, T<sub>A</sub> = T<sub>low</sub> to T<sub>high</sub> [Note 3])

| Characteristic  | Symbol            | LM239A/339A |     |                         | LM239/339 |     |                         | LM2901/2901V |     |                         | MC3302 |     |                         | Unit |
|---|-------------------|-------------|-----|-------------------------|-----------|-----|-------------------------|--------------|-----|-------------------------|--------|-----|-------------------------|------|
|   |                   | Min         | Typ | Max                     | Min       | Typ | Max                     | Min          | Typ | Max                     | Min    | Typ | Max                     |      |
| Input Offset Voltage (Note 4)   | V <sub>IO</sub>   | -           | -   | ±4.0                    | -         | -   | ±9.0                    | -            | -   | ±15                     | -      | -   | ±40                     | mVdc |
| Input Bias Current (Notes 4, 5)<br>(Output in Analog Range)   | I <sub>IB</sub>   | -           | -   | 400                     | -         | -   | 400                     | -            | -   | 500                     | -      | -   | 1000                    | nA   |
| Input Offset Current (Note 4)   | I <sub>IO</sub>   | -           | -   | ±150                    | -         | -   | ±150                    | -            | -   | ±200                    | -      | -   | ±300                    | nA   |
| Input Common Mode Voltage Range   | V <sub>ICMR</sub> | 0           | -   | V <sub>CC</sub><br>-2.0 | 0         | -   | V <sub>CC</sub><br>-2.0 | 0            | -   | V <sub>CC</sub><br>-2.0 | 0      | -   | V <sub>CC</sub><br>-2.0 | V    |
| Saturation Voltage<br>V <sub>I</sub> (-) ≥ +1.0 Vdc, V <sub>I</sub> (+) = 0,<br>I <sub>sink</sub> ≤ 4.0 mA  | V <sub>sat</sub>  | -           | -   | 700                     | -         | -   | 700                     | -            | -   | 700                     | -      | -   | 700                     | mV   |
| Output Leakage Current<br>V <sub>I</sub> (+) ≥ +1.0 Vdc, V <sub>I</sub> (-) = 0,<br>V <sub>O</sub> = 30 Vdc | I <sub>OL</sub>   | -           | -   | 1.0                     | -         | -   | 1.0                     | -            | -   | 1.0                     | -      | -   | 1.0                     | μA   |
| Differential Input Voltage<br>All V <sub>I</sub> ≥ 0 Vdc  | V <sub>ID</sub>   | -           | -   | V <sub>CC</sub>         | -         | -   | V <sub>CC</sub>         | -            | -   | V <sub>CC</sub>         | -      | -   | V <sub>CC</sub>         | Vdc  |

NOTES: 3. (LM239/239A) T<sub>low</sub> = -25°C, T<sub>high</sub> = +85°C

(LM339/339A) T<sub>low</sub> = 0°C, T<sub>high</sub> = +70°C

(MC3302) T<sub>low</sub> = -40°C, T<sub>high</sub> = +85°C

(LM2901) T<sub>low</sub> = -40°C, T<sub>high</sub> = +105°C

(LM2901V) T<sub>low</sub> = -40°C, T<sub>high</sub> = +125°C

4. At the output switch point, V<sub>O</sub> = 1.4 Vdc, R<sub>S</sub> ≤ 100 Ω, 5.0 Vdc ≤ V<sub>CC</sub> ≤ 30 Vdc, with the inputs over the full common mode range (0 Vdc to V<sub>CC</sub> - 1.5 Vdc).

5. The bias current flows out of the inputs due to the PNP input stage. This current is virtually constant, independent of the output state.

6. The response time specified is for a 100 mV input step with 5.0 mV overdrive. For larger signals, 300 ns is typical.

Figure 2. Inverting Comparator with Hysteresis

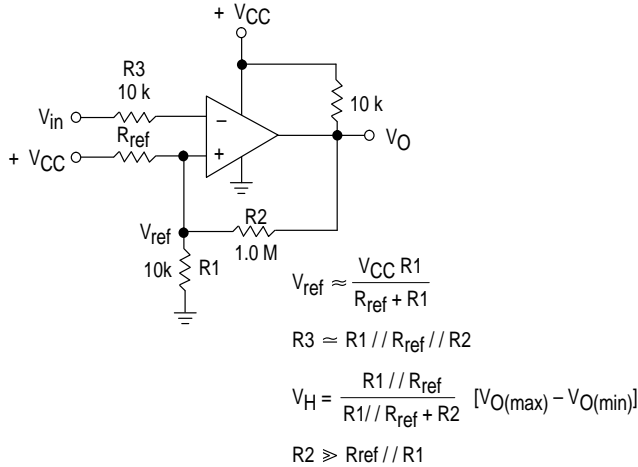
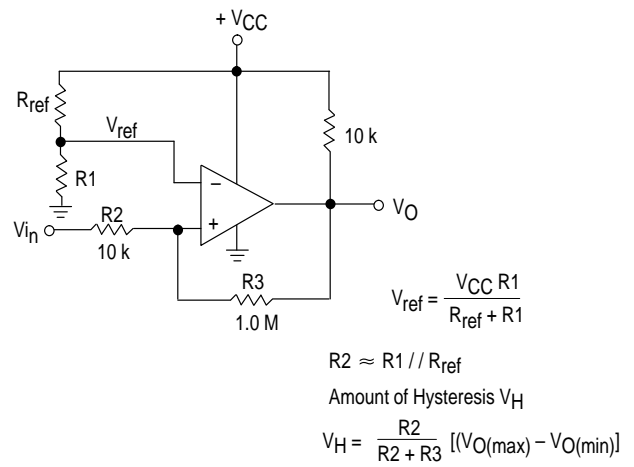

Figure 3. Noninverting Comparator with Hysteresis



Typical Characteristics

(VCC = 15 Vdc, TA = +25°C (each comparator) unless otherwise noted.)

Figure 4. Normalized Input Offset Voltage

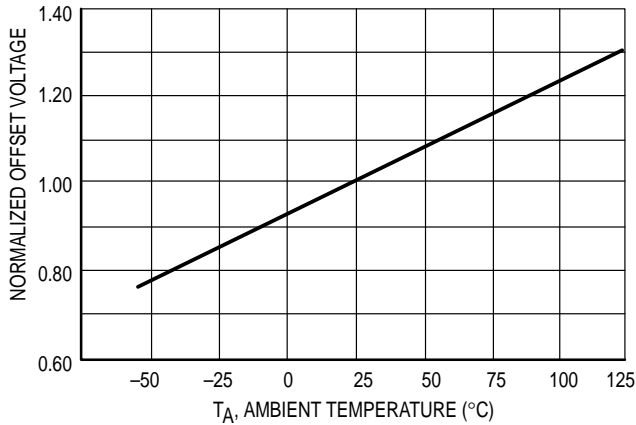

Figure 5. Input Bias Current

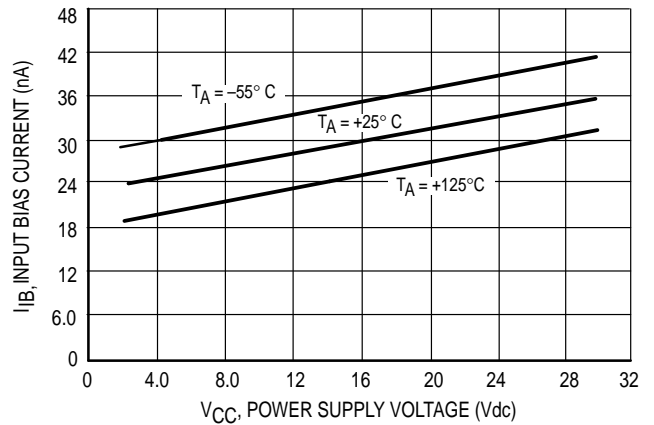
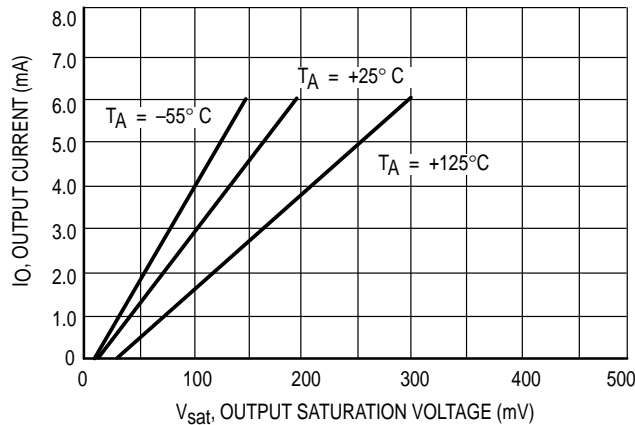
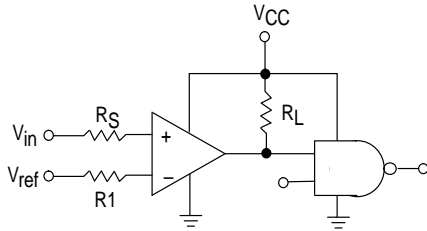

Figure 6. Output Sink Current versus Output Saturation Voltage



# LM339, LM339A, LM239, LM239A, LM2901, M2901V, MC3302

**Figure 7. Driving Logic**



$R_S$  = Source Resistance  
 $R_1 \approx R_S$

| Logic | Device      | V <sub>CC</sub> (V) | R <sub>L</sub> kΩ |
|-------|-------------|---------------------|-------------------|
| CMOS  | 1/4 MC14001 | +15                 | 100               |
| TTL   | 1/4 MC7400  | +5.0                | 10                |

**Figure 8. Squarewave Oscillator**

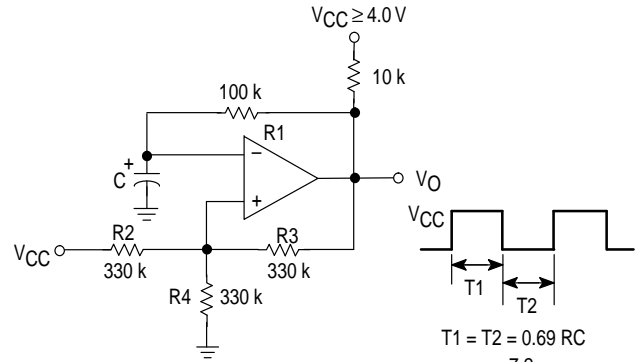

$$T_1 = T_2 = 0.69 RC$$

$$f \approx \frac{7.2}{C(\mu F)}$$

$$R_2 = R_3 = R_4$$

$$R_1 \approx R_2 // R_3 // R_4$$

## APPLICATIONS INFORMATION

These quad comparators feature high gain, wide bandwidth characteristics. This gives the device oscillation tendencies if the outputs are capacitively coupled to the inputs via stray capacitance. This oscillation manifests itself during output transitions ( $V_{OL}$  to  $V_{OH}$ ). To alleviate this situation input resistors  $< 10\text{ k}\Omega$  should be used. The addition

of positive feedback ( $< 10\text{ mV}$ ) is also recommended. It is good design practice to ground all unused input pins.

Differential input voltages may be larger than supply voltages without damaging the comparator's inputs. Voltages more negative than  $-300\text{ mV}$  should not be used.

**Figure 9. Zero Crossing Detector (Single Supply)**

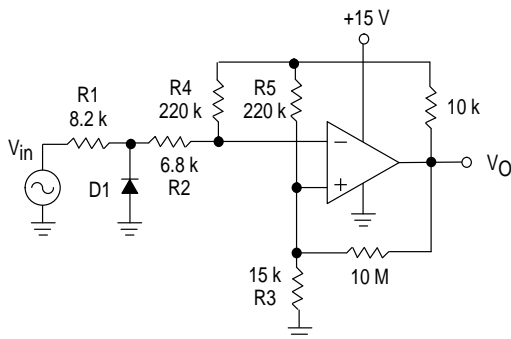

D1 prevents input from going negative by more than 0.6 V.

$$R_1 + R_2 = R_3$$

$$R_3 \leq \frac{R_5}{10} \text{ for small error in zero crossing}$$

**Figure 10. Zero Crossing Detector (Split Supplies)**

$V_{in(min)} \approx 0.4\text{ V}$  peak for 1% phase distortion ( $\Delta\theta$ ).

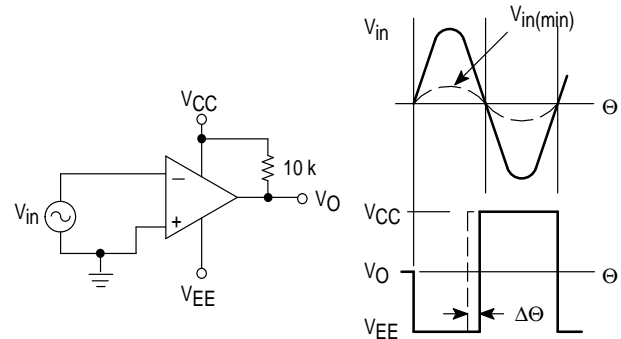

OUTLINE DIMENSIONS

**N, P SUFFIX**  
 PLASTIC PACKAGE  
 CASE 646-06  
 ISSUE L

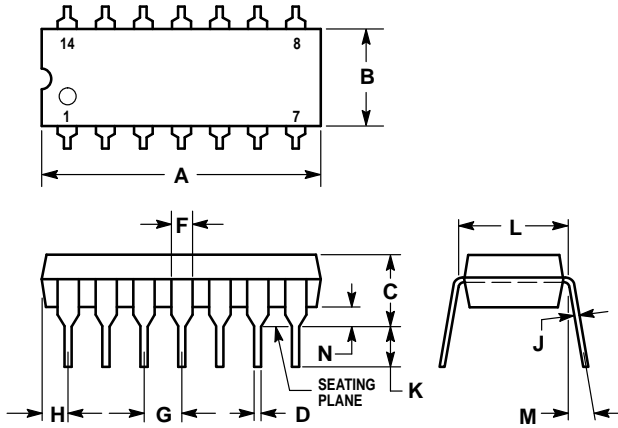

- NOTES:
- LEADS WITHIN 0.13 (0.005) RADIUS OF TRUE POSITION AT SEATING PLANE AT MAXIMUM MATERIAL CONDITION.
  - DIMENSION L TO CENTER OF LEADS WHEN FORMED PARALLEL.
  - DIMENSION B DOES NOT INCLUDE MOLD FLASH.
  - ROUNDED CORNERS OPTIONAL.

| DIM | INCHES    |       | MILLIMETERS |       |
|-----|-----------|-------|-------------|-------|
|     | MIN       | MAX   | MIN         | MAX   |
| A   | 0.715     | 0.770 | 18.16       | 19.56 |
| B   | 0.240     | 0.260 | 6.10        | 6.60  |
| C   | 0.145     | 0.185 | 3.69        | 4.69  |
| D   | 0.015     | 0.021 | 0.38        | 0.53  |
| F   | 0.040     | 0.070 | 1.02        | 1.78  |
| G   | 0.100 BSC |       | 2.54 BSC    |       |
| H   | 0.052     | 0.095 | 1.32        | 2.41  |
| J   | 0.008     | 0.015 | 0.20        | 0.38  |
| K   | 0.115     | 0.135 | 2.92        | 3.43  |
| L   | 0.300 BSC |       | 7.62 BSC    |       |
| M   | 0°        | 10°   | 0°          | 10°   |
| N   | 0.015     | 0.039 | 0.39        | 1.01  |

**D SUFFIX**  
 PLASTIC PACKAGE  
 CASE 751A-03  
 (SO-14)  
 ISSUE F

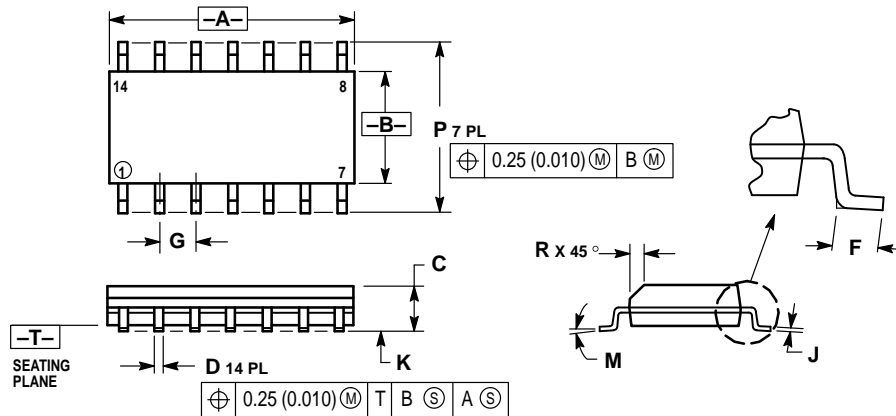

- NOTES:
- DIMENSIONING AND TOLERANCING PER ANSI Y14.5M, 1982.
  - CONTROLLING DIMENSION: MILLIMETER.
  - DIMENSIONS A AND B DO NOT INCLUDE MOLD PROTRUSION.
  - MAXIMUM MOLD PROTRUSION 0.15 (0.006) PER SIDE.
  - DIMENSION D DOES NOT INCLUDE DAMBAR PROTRUSION. ALLOWABLE DAMBAR PROTRUSION SHALL BE 0.127 (0.005) TOTAL IN EXCESS OF THE D DIMENSION AT MAXIMUM MATERIAL CONDITION.

| DIM | MILLIMETERS |      | INCHES    |       |
|-----|-------------|------|-----------|-------|
|     | MIN         | MAX  | MIN       | MAX   |
| A   | 8.55        | 8.75 | 0.337     | 0.344 |
| B   | 3.80        | 4.00 | 0.150     | 0.157 |
| C   | 1.35        | 1.75 | 0.054     | 0.068 |
| D   | 0.35        | 0.49 | 0.014     | 0.019 |
| F   | 0.40        | 1.25 | 0.016     | 0.049 |
| G   | 1.27 BSC    |      | 0.050 BSC |       |
| J   | 0.19        | 0.25 | 0.008     | 0.009 |
| K   | 0.10        | 0.25 | 0.004     | 0.009 |
| M   | 0°          | 7°   | 0°        | 7°    |
| P   | 5.80        | 6.20 | 0.228     | 0.244 |
| R   | 0.25        | 0.50 | 0.010     | 0.019 |