

## Positive voltage regulators

### Feature summary

- Output current to 1.5A
- Output voltages of 5; 5.2; 6; 8; 8.5; 9; 10; 12; 15; 18; 24V
- Thermal overload protection
- Short circuit protection
- Output transition SOA protection

### Description

The L7800 series of three-terminal positive regulators is available in TO-220, TO-220FP, TO-3 and D<sup>2</sup>PAK packages and several fixed output voltages, making it useful in a wide range of applications. These regulators can provide local on-card regulation, eliminating the distribution problems associated with single point regulation. Each type employs internal current limiting, thermal shut-down and safe area protection, making it essentially indestructible. If adequate heat sinking is provided, they can deliver over 1A output current. Although designed

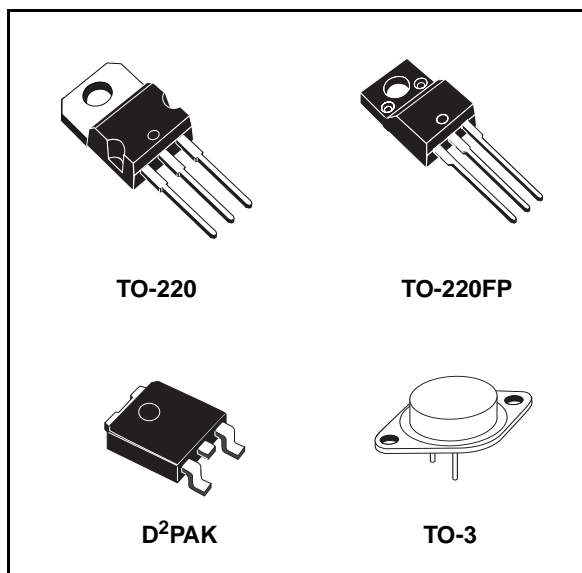

primarily as fixed voltage regulators, these devices can be used with external components to obtain adjustable voltage and currents.

### Schematic diagram

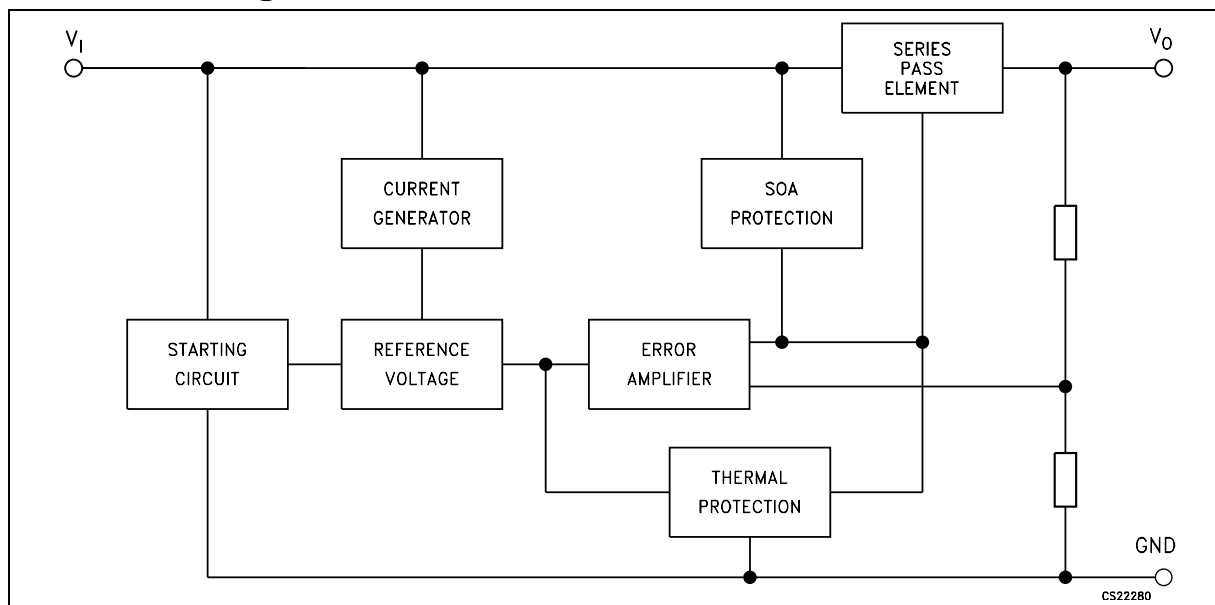

---

## Contents

1	Pin configuration .....	3
2	Maximum ratings .....	4
3	Test circuits .....	5
4	Electrical characteristics .....	6
5	Typical performance .....	26
6	Package mechanical data .....	36
7	Order code .....	46
8	Revision history .....	47

# 1 Pin configuration

Figure 1. Pin connections (top view)

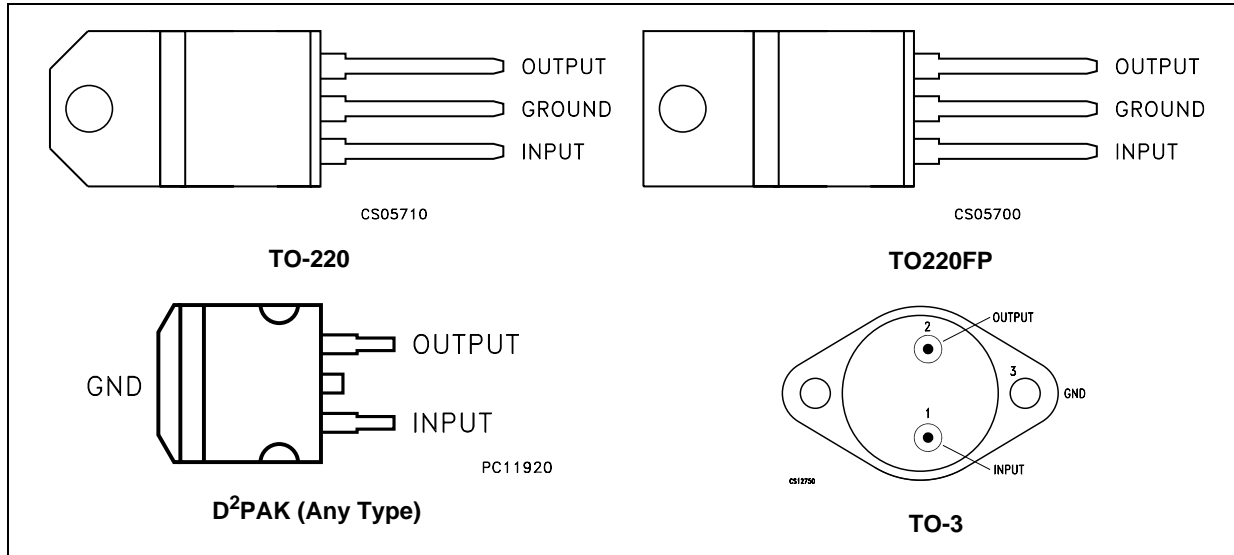
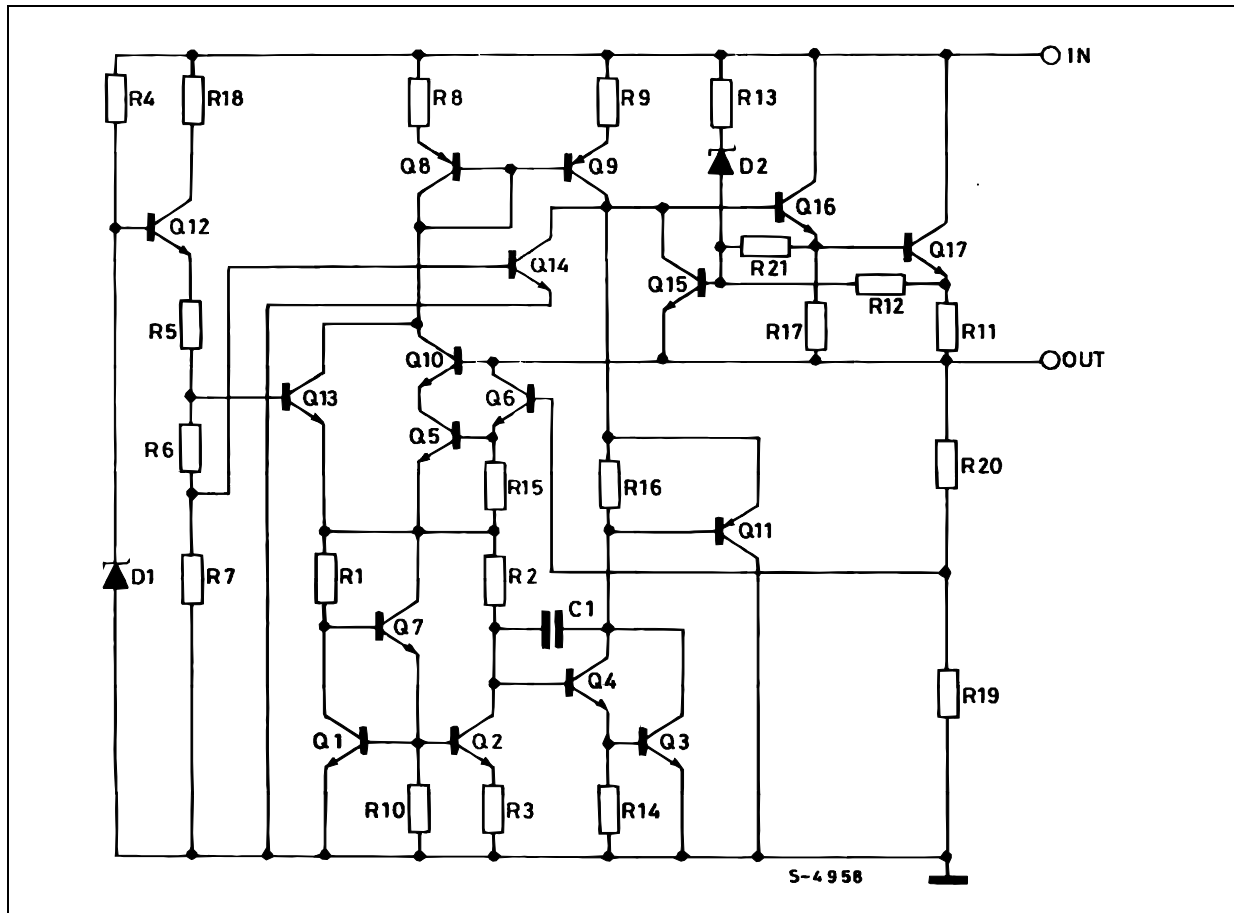

Figure 2. Schematic diagram



## 2 Maximum ratings

**Table 1. Absolute maximum ratings**

Symbol	Parameter		Value	Unit
$V_I$	DC Input voltage	for $V_O = 5$ to $18V$	35	V
		for $V_O = 20, 24V$	40	
$I_O$	Output current		Internally Limited	
$P_D$	Power dissipation		Internally Limited	
$T_{STG}$	Storage temperature range		-65 to 150	°C
$T_{OP}$	Operating junction temperature range	for L7800	-55 to 150	°C
		for L7800C	0 to 150	

*Note: Absolute Maximum Ratings are those values beyond which damage to the device may occur. Functional operation under these condition is not implied*

**Table 2. Thermal Data**

Symbol	Parameter	D <sup>2</sup> PAK	TO-220	TO-220FP	TO-3	Unit
$R_{thJC}$	Thermal resistance junction-case	3	5	5	4	°C/W
$R_{thJA}$	Thermal resistance junction-ambient	62.5	50	60	35	°C/W

**Figure 3. Application circuits**

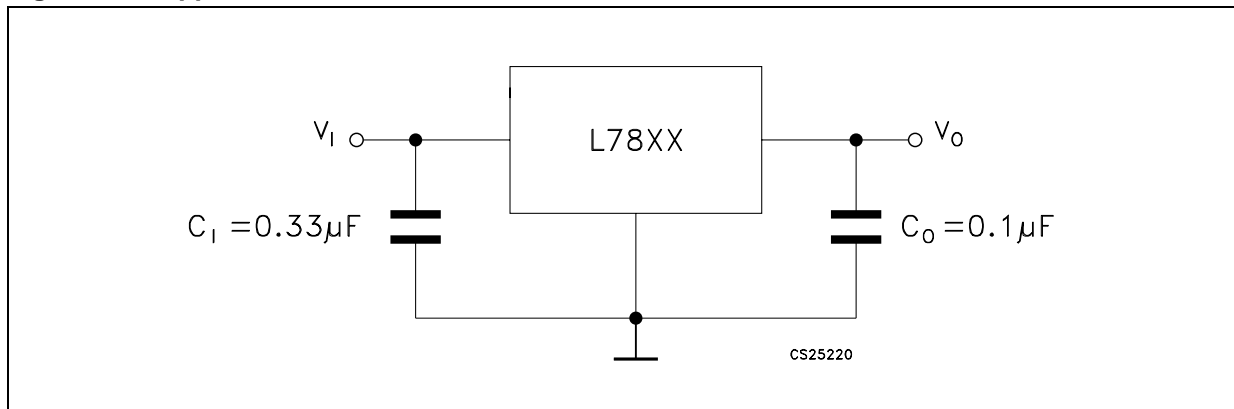

### 3 Test circuits

Figure 4. DC Parameter

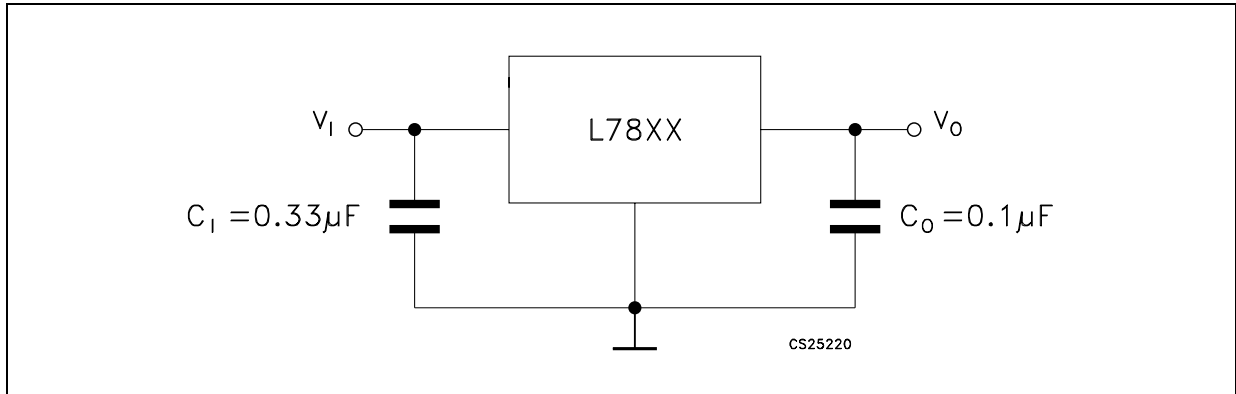

Figure 5. Load regulation

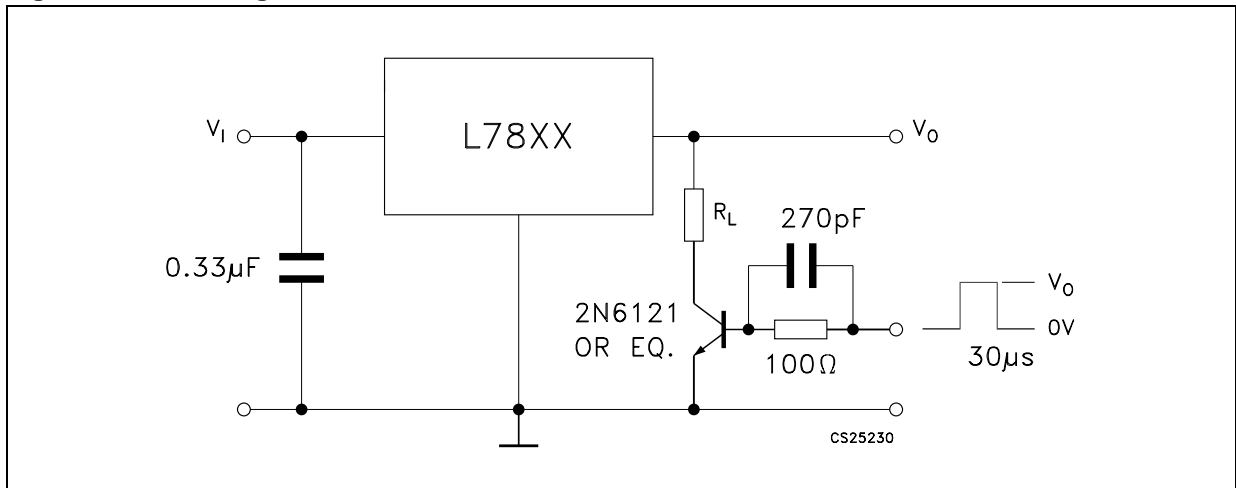
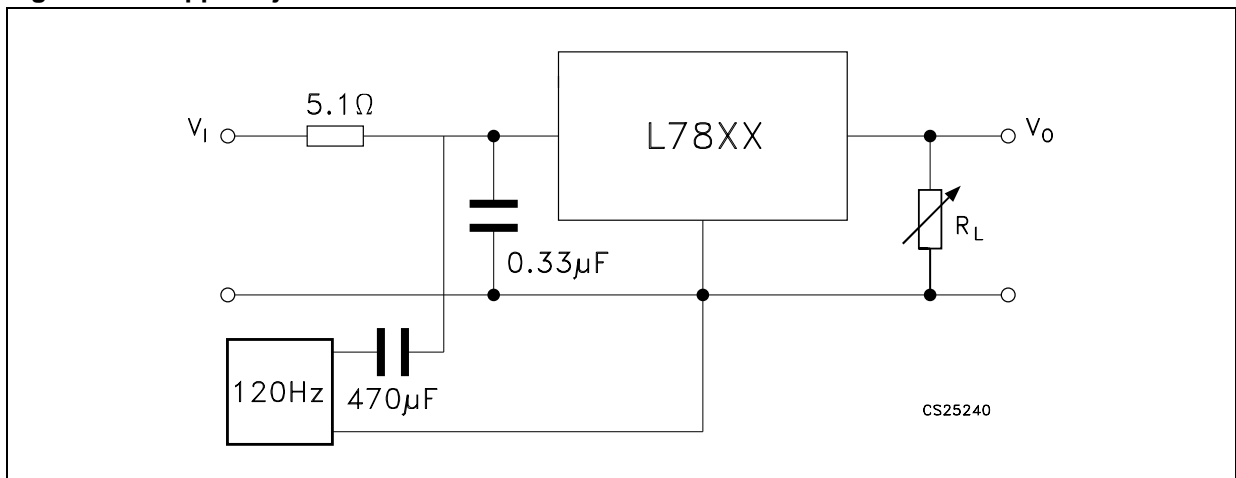

Figure 6. Ripple rejection



## 4 Electrical characteristics

**Table 3. Electrical characteristics of L7805** (refer to the test circuits,  $T_J = -55$  to  $150^\circ\text{C}$ ,  $V_I = 10\text{V}$ ,  $I_O = 500\text{ mA}$ ,  $C_I = 0.33\ \mu\text{F}$ ,  $C_O = 0.1\ \mu\text{F}$  unless otherwise specified)

Symbol	Parameter	Test conditions	Min.	Typ.	Max.	Unit
$V_O$	Output voltage	$T_J = 25^\circ\text{C}$	4.8	5	5.2	V
$V_O$	Output voltage	$I_O = 5\text{mA to } 1\text{A}$ , $P_O \leq 15\text{W}$ $V_I = 8$ to $20\text{V}$	4.65	5	5.35	V
$\Delta V_O^{(1)}$	Line regulation	$V_I = 7$ to $25\text{V}$ , $T_J = 25^\circ\text{C}$		3	50	mV
		$V_I = 8$ to $12\text{V}$ , $T_J = 25^\circ\text{C}$		1	25	
$\Delta V_O^{(1)}$	Load regulation	$I_O = 5\text{ mA to } 1.5\text{A}$ , $T_J = 25^\circ\text{C}$			100	mV
		$I_O = 250$ to $750\text{mA}$ , $T_J = 25^\circ\text{C}$			25	
$I_d$	Quiescent current	$T_J = 25^\circ\text{C}$			6	mA
$\Delta I_d$	Quiescent current change	$I_O = 5\text{mA to } 1\text{A}$			0.5	mA
		$V_I = 8$ to $25\text{ V}$			0.8	
$\Delta V_O/\Delta T$	Output voltage drift	$I_O = 5\text{mA}$		0.6		mV/ $^\circ\text{C}$
eN	Output noise voltage	$B = 10\text{Hz to } 100\text{KHz}$ , $T_J = 25^\circ\text{C}$			40	$\mu\text{V}/V_O$
SVR	Supply voltage rejection	$V_I = 8$ to $18\text{V}$ , $f = 120\text{Hz}$	68			dB
$V_d$	Dropout voltage	$I_O = 1\text{A}$ , $T_J = 25^\circ\text{C}$		2	2.5	V
$R_O$	Output resistance	$f = 1\text{ KHz}$		17		m $\Omega$
$I_{sc}$	Short circuit current	$V_I = 35\text{V}$ , $T_J = 25^\circ\text{C}$		0.75	1.2	A
$I_{scp}$	Short circuit peak current	$T_J = 25^\circ\text{C}$	1.3	2.2	3.3	A

1. Load and line regulation are specified at constant junction temperature. Changes in  $V_O$  due to heating effects must be taken into account separately. Pulse testing with low duty cycle is used.

**Table 4. Electrical characteristics of L7806** (refer to the test circuits,  $T_J = -55$  to  $150^\circ\text{C}$ ,  $V_I = 11\text{V}$ ,  $I_O = 500\text{ mA}$ ,  $C_I = 0.33\text{ }\mu\text{F}$ ,  $C_O = 0.1\text{ }\mu\text{F}$  unless otherwise specified)

Symbol	Parameter	Test conditions	Min.	Typ.	Max.	Unit
$V_O$	Output voltage	$T_J = 25^\circ\text{C}$	5.75	6	6.25	V
$V_O$	Output voltage	$I_O = 5\text{mA to }1\text{A}$ , $P_O \leq 15\text{W}$ $V_I = 9$ to $21\text{V}$	5.65	6	6.35	V
$\Delta V_O^{(1)}$	Line regulation	$V_I = 8$ to $25\text{V}$ , $T_J = 25^\circ\text{C}$			60	mV
		$V_I = 9$ to $13\text{V}$ , $T_J = 25^\circ\text{C}$			30	
$\Delta V_O^{(1)}$	Load regulation	$I_O = 5\text{ mA to }1.5\text{A}$ , $T_J = 25^\circ\text{C}$			100	mV
		$I_O = 250$ to $750\text{mA}$ , $T_J = 25^\circ\text{C}$			30	
$I_d$	Quiescent current	$T_J = 25^\circ\text{C}$			6	mA
$\Delta I_d$	Quiescent current change	$I_O = 5\text{mA to }1\text{A}$			0.5	mA
		$V_I = 9$ to $25\text{V}$			0.8	
$\Delta V_O/\Delta T$	Output voltage drift	$I_O = 5\text{mA}$		0.7		mV/ $^\circ\text{C}$
eN	Output noise voltage	$B = 10\text{Hz to }100\text{KHz}$ , $T_J = 25^\circ\text{C}$			40	$\mu\text{V}/V_O$
SVR	Supply voltage rejection	$V_I = 9$ to $19\text{V}$ , $f = 120\text{Hz}$	65			dB
$V_d$	Dropout voltage	$I_O = 1\text{A}$ , $T_J = 25^\circ\text{C}$		2	2.5	V
$R_O$	Output resistance	$f = 1\text{ KHz}$		19		m $\Omega$
$I_{sc}$	Short circuit current	$V_I = 35\text{V}$ , $T_J = 25^\circ\text{C}$		0.75	1.2	A
$I_{scp}$	Short circuit peak current	$T_J = 25^\circ\text{C}$	1.3	2.2	3.3	A

1. Load and line regulation are specified at constant junction temperature. Changes in  $V_O$  due to heating effects must be taken into account separately. Pulse testing with low duty cycle is used.

**Table 5. Electrical characteristics of L7808** (refer to the test circuits,  $T_J = -55$  to  $150^\circ\text{C}$ ,  $V_I = 14\text{V}$ ,  $I_O = 500\text{ mA}$ ,  $C_I = 0.33\ \mu\text{F}$ ,  $C_O = 0.1\ \mu\text{F}$  unless otherwise specified)

Symbol	Parameter	Test conditions	Min.	Typ.	Max.	Unit
$V_O$	Output voltage	$T_J = 25^\circ\text{C}$	7.7	8	8.3	V
$V_O$	Output voltage	$I_O = 5\text{mA to } 1\text{A}$ , $P_O \leq 15\text{W}$ $V_I = 11.5$ to $23\text{V}$	7.6	8	8.4	V
$\Delta V_O^{(1)}$	Line regulation	$V_I = 10.5$ to $25\text{V}$ , $T_J = 25^\circ\text{C}$			80	mV
		$V_I = 11$ to $17\text{V}$ , $T_J = 25^\circ\text{C}$			40	
$\Delta V_O^{(1)}$	Load regulation	$I_O = 5\text{ mA to } 1.5\text{A}$ , $T_J = 25^\circ\text{C}$			100	mV
		$I_O = 250$ to $750\text{mA}$ , $T_J = 25^\circ\text{C}$			40	
$I_d$	Quiescent current	$T_J = 25^\circ\text{C}$			6	mA
$\Delta I_d$	Quiescent current change	$I_O = 5\text{mA to } 1\text{A}$			0.5	mA
		$V_I = 11.5$ to $25\text{V}$			0.8	
$\Delta V_O/\Delta T$	Output voltage drift	$I_O = 5\text{mA}$		1		mV/ $^\circ\text{C}$
eN	Output noise voltage	$B = 10\text{Hz to } 100\text{KHz}$ , $T_J = 25^\circ\text{C}$			40	$\mu\text{V}/V_O$
SVR	Supply voltage rejection	$V_I = 11.5$ to $21.5\text{V}$ , $f = 120\text{Hz}$	62			dB
$V_d$	Dropout voltage	$I_O = 1\text{A}$ , $T_J = 25^\circ\text{C}$		2	2.5	V
$R_O$	Output resistance	$f = 1\text{ KHz}$		16		m $\Omega$
$I_{sc}$	Short circuit current	$V_I = 35\text{V}$ , $T_J = 25^\circ\text{C}$		0.75	1.2	A
$I_{scp}$	Short circuit peak current	$T_J = 25^\circ\text{C}$	1.3	2.2	3.3	A

1. Load and line regulation are specified at constant junction temperature. Changes in  $V_O$  due to heating effects must be taken into account separately. Pulse testing with low duty cycle is used.

**Table 6. Electrical characteristics of L7812** (refer to the test circuits,  $T_J = -55$  to  $150^\circ\text{C}$ ,  $V_I = 19\text{V}$ ,  $I_O = 500\text{ mA}$ ,  $C_I = 0.33\text{ }\mu\text{F}$ ,  $C_O = 0.1\text{ }\mu\text{F}$  unless otherwise specified)

Symbol	Parameter	Test conditions	Min.	Typ.	Max.	Unit
$V_O$	Output voltage	$T_J = 25^\circ\text{C}$	11.5	12	12.5	V
$V_O$	Output voltage	$I_O = 5\text{mA to }1\text{A}$ , $P_O \leq 15\text{W}$ $V_I = 15.5$ to $27\text{V}$	11.4	12	12.6	V
$\Delta V_O^{(1)}$	Line regulation	$V_I = 14.5$ to $30\text{V}$ , $T_J = 25^\circ\text{C}$			120	mV
		$V_I = 16$ to $22\text{V}$ , $T_J = 25^\circ\text{C}$			60	
$\Delta V_O^{(1)}$	Load regulation	$I_O = 5\text{ mA to }1.5\text{A}$ , $T_J = 25^\circ\text{C}$			100	mV
		$I_O = 250$ to $750\text{mA}$ , $T_J = 25^\circ\text{C}$			60	
$I_d$	Quiescent current	$T_J = 25^\circ\text{C}$			6	mA
$\Delta I_d$	Quiescent current change	$I_O = 5\text{mA to }1\text{A}$			0.5	mA
		$V_I = 15$ to $30\text{V}$			0.8	
$\Delta V_O/\Delta T$	Output voltage drift	$I_O = 5\text{mA}$		1.5		mV/ $^\circ\text{C}$
eN	Output noise voltage	$B = 10\text{Hz to }100\text{KHz}$ , $T_J = 25^\circ\text{C}$			40	$\mu\text{V}/V_O$
SVR	Supply voltage rejection	$V_I = 15$ to $25\text{V}$ , $f = 120\text{Hz}$	61			dB
$V_d$	Dropout voltage	$I_O = 1\text{A}$ , $T_J = 25^\circ\text{C}$		2	2.5	V
$R_O$	Output resistance	$f = 1\text{ KHz}$		18		m $\Omega$
$I_{sc}$	Short circuit current	$V_I = 35\text{V}$ , $T_J = 25^\circ\text{C}$		0.75	1.2	A
$I_{scp}$	Short circuit peak current	$T_J = 25^\circ\text{C}$	1.3	2.2	3.3	A

1. Load and line regulation are specified at constant junction temperature. Changes in  $V_O$  due to heating effects must be taken into account separately. Pulse testing with low duty cycle is used.

**Table 7. Electrical characteristics of L7815** (refer to the test circuits,  $T_J = -55$  to  $150^\circ\text{C}$ ,  $V_I = 23\text{V}$ ,  $I_O = 500\text{ mA}$ ,  $C_I = 0.33\ \mu\text{F}$ ,  $C_O = 0.1\ \mu\text{F}$  unless otherwise specified)

Symbol	Parameter	Test conditions	Min.	Typ.	Max.	Unit
$V_O$	Output voltage	$T_J = 25^\circ\text{C}$	14.4	15	15.6	V
$V_O$	Output voltage	$I_O = 5\text{mA to } 1\text{A}$ , $P_O \leq 15\text{W}$ $V_I = 18.5$ to $30\text{V}$	14.25	15	15.75	V
$\Delta V_O^{(1)}$	Line regulation	$V_I = 17.5$ to $30\text{V}$ , $T_J = 25^\circ\text{C}$			150	mV
		$V_I = 20$ to $26\text{V}$ , $T_J = 25^\circ\text{C}$			75	
$\Delta V_O^{(1)}$	Load regulation	$I_O = 5\text{ mA to } 1.5\text{A}$ , $T_J = 25^\circ\text{C}$			150	mV
		$I_O = 250$ to $750\text{mA}$ , $T_J = 25^\circ\text{C}$			75	
$I_d$	Quiescent current	$T_J = 25^\circ\text{C}$			6	mA
$\Delta I_d$	Quiescent current change	$I_O = 5\text{mA to } 1\text{A}$			0.5	mA
		$V_I = 18.5$ to $30\text{V}$			0.8	
$\Delta V_O/\Delta T$	Output voltage drift	$I_O = 5\text{mA}$		1.8		mV/ $^\circ\text{C}$
eN	Output noise voltage	$B = 10\text{Hz to } 100\text{KHz}$ , $T_J = 25^\circ\text{C}$			40	$\mu\text{V}/V_O$
SVR	Supply voltage rejection	$V_I = 18.5$ to $28.5\text{V}$ , $f = 120\text{Hz}$	60			dB
$V_d$	Dropout voltage	$I_O = 1\text{A}$ , $T_J = 25^\circ\text{C}$		2	2.5	V
$R_O$	Output resistance	$f = 1\text{ KHz}$		19		m $\Omega$
$I_{sc}$	Short circuit current	$V_I = 35\text{V}$ , $T_J = 25^\circ\text{C}$		0.75	1.2	A
$I_{scp}$	Short circuit peak current	$T_J = 25^\circ\text{C}$	1.3	2.2	3.3	A

1. Load and line regulation are specified at constant junction temperature. Changes in  $V_O$  due to heating effects must be taken into account separately. Pulse testing with low duty cycle is used.

**Table 8. Electrical characteristics of L7818** (refer to the test circuits,  $T_J = -55$  to  $150^\circ\text{C}$ ,  $V_I = 26\text{V}$ ,  $I_O = 500\text{ mA}$ ,  $C_I = 0.33\ \mu\text{F}$ ,  $C_O = 0.1\ \mu\text{F}$  unless otherwise specified)

Symbol	Parameter	Test conditions	Min.	Typ.	Max.	Unit
$V_O$	Output voltage	$T_J = 25^\circ\text{C}$	17.3	18	18.7	V
$V_O$	Output voltage	$I_O = 5\text{mA to } 1\text{A}$ , $P_O \leq 15\text{W}$ $V_I = 22$ to $33\text{V}$	17.1	18	18.9	V
$\Delta V_O^{(1)}$	Line regulation	$V_I = 21$ to $33\text{V}$ , $T_J = 25^\circ\text{C}$			180	mV
		$V_I = 24$ to $30\text{V}$ , $T_J = 25^\circ\text{C}$			90	
$\Delta V_O^{(1)}$	Load regulation	$I_O = 5\text{ mA to } 1.5\text{A}$ , $T_J = 25^\circ\text{C}$			180	mV
		$I_O = 250$ to $750\text{mA}$ , $T_J = 25^\circ\text{C}$			90	
$I_d$	Quiescent current	$T_J = 25^\circ\text{C}$			6	mA
$\Delta I_d$	Quiescent current change	$I_O = 5\text{mA to } 1\text{A}$			0.5	mA
		$V_I = 22$ to $33\text{V}$			0.8	
$\Delta V_O/\Delta T$	Output voltage drift	$I_O = 5\text{mA}$		2.3		mV/ $^\circ\text{C}$
eN	Output noise voltage	$B = 10\text{Hz to } 100\text{KHz}$ , $T_J = 25^\circ\text{C}$			40	$\mu\text{V}/V_O$
SVR	Supply voltage rejection	$V_I = 22$ to $32\text{V}$ , $f = 120\text{Hz}$	59			dB
$V_d$	Dropout voltage	$I_O = 1\text{A}$ , $T_J = 25^\circ\text{C}$		2	2.5	V
$R_O$	Output resistance	$f = 1\text{ KHz}$		22		m $\Omega$
$I_{sc}$	Short circuit current	$V_I = 35\text{V}$ , $T_J = 25^\circ\text{C}$		0.75	1.2	A
$I_{scp}$	Short circuit peak current	$T_J = 25^\circ\text{C}$	1.3	2.2	3.3	A

1. Load and line regulation are specified at constant junction temperature. Changes in  $V_O$  due to heating effects must be taken into account separately. Pulse testing with low duty cycle is used.

**Table 9. Electrical characteristics of L7820** (refer to the test circuits,  $T_J = -55$  to  $150^\circ\text{C}$ ,  $V_I = 28\text{V}$ ,  $I_O = 500\text{ mA}$ ,  $C_I = 0.33\ \mu\text{F}$ ,  $C_O = 0.1\ \mu\text{F}$  unless otherwise specified)

Symbol	Parameter	Test conditions	Min.	Typ.	Max.	Unit
$V_O$	Output voltage	$T_J = 25^\circ\text{C}$	19.2	20	20.8	V
$V_O$	Output voltage	$I_O = 5\text{mA to } 1\text{A}$ , $P_O \leq 15\text{W}$ $V_I = 24$ to $35\text{V}$	19	20	21	V
$\Delta V_O^{(1)}$	Line regulation	$V_I = 22.5$ to $35\text{V}$ , $T_J = 25^\circ\text{C}$			200	mV
		$V_I = 26$ to $32\text{V}$ , $T_J = 25^\circ\text{C}$			100	
$\Delta V_O^{(1)}$	Load regulation	$I_O = 5\text{ mA to } 1.5\text{A}$ , $T_J = 25^\circ\text{C}$			200	mV
		$I_O = 250$ to $750\text{mA}$ , $T_J = 25^\circ\text{C}$			100	
$I_d$	Quiescent current	$T_J = 25^\circ\text{C}$			6	mA
$\Delta I_d$	Quiescent current change	$I_O = 5\text{mA to } 1\text{A}$			0.5	mA
		$V_I = 24$ to $35\text{V}$			0.8	
$\Delta V_O/\Delta T$	Output voltage drift	$I_O = 5\text{mA}$		2.5		mV/ $^\circ\text{C}$
eN	Output noise voltage	$B = 10\text{Hz to } 100\text{KHz}$ , $T_J = 25^\circ\text{C}$			40	$\mu\text{V}/V_O$
SVR	Supply voltage rejection	$V_I = 24$ to $35\text{V}$ , $f = 120\text{Hz}$	58			dB
$V_d$	Dropout voltage	$I_O = 1\text{A}$ , $T_J = 25^\circ\text{C}$		2	2.5	V
$R_O$	Output resistance	$f = 1\text{ KHz}$		24		m $\Omega$
$I_{sc}$	Short circuit current	$V_I = 35\text{V}$ , $T_J = 25^\circ\text{C}$		0.75	1.2	A
$I_{scp}$	Short circuit peak current	$T_J = 25^\circ\text{C}$	1.3	2.2	3.3	A

1. Load and line regulation are specified at constant junction temperature. Changes in  $V_O$  due to heating effects must be taken into account separately. Pulse testing with low duty cycle is used.

**Table 10. Electrical characteristics of L7824** (refer to the test circuits,  $T_J = -55$  to  $150^\circ\text{C}$ ,  $V_I = 33\text{V}$ ,  $I_O = 500\text{ mA}$ ,  $C_I = 0.33\text{ }\mu\text{F}$ ,  $C_O = 0.1\text{ }\mu\text{F}$  unless otherwise specified)

Symbol	Parameter	Test conditions	Min.	Typ.	Max.	Unit
$V_O$	Output voltage	$T_J = 25^\circ\text{C}$	23	24	25	V
$V_O$	Output voltage	$I_O = 5\text{mA to }1\text{A}$ , $P_O \leq 15\text{W}$ $V_I = 28$ to $38\text{V}$	22.8	24	25.2	V
$\Delta V_O^{(1)}$	Line regulation	$V_I = 27$ to $38\text{V}$ , $T_J = 25^\circ\text{C}$			240	mV
		$V_I = 30$ to $36\text{V}$ , $T_J = 25^\circ\text{C}$			120	
$\Delta V_O^{(1)}$	Load regulation	$I_O = 5\text{ mA to }1.5\text{A}$ , $T_J = 25^\circ\text{C}$			240	mV
		$I_O = 250$ to $750\text{mA}$ , $T_J = 25^\circ\text{C}$			120	
$I_d$	Quiescent current	$T_J = 25^\circ\text{C}$			6	mA
$\Delta I_d$	Quiescent current change	$I_O = 5\text{mA to }1\text{A}$			0.5	mA
		$V_I = 28$ to $38\text{V}$			0.8	
$\Delta V_O/\Delta T$	Output voltage drift	$I_O = 5\text{mA}$		3		mV/ $^\circ\text{C}$
eN	Output noise voltage	$B = 10\text{Hz to }100\text{KHz}$ , $T_J = 25^\circ\text{C}$			40	$\mu\text{V}/V_O$
SVR	Supply voltage rejection	$V_I = 28$ to $38\text{V}$ , $f = 120\text{Hz}$	56			dB
$V_d$	Dropout voltage	$I_O = 1\text{A}$ , $T_J = 25^\circ\text{C}$		2	2.5	V
$R_O$	Output resistance	$f = 1\text{ KHz}$		28		m $\Omega$
$I_{sc}$	Short circuit current	$V_I = 35\text{V}$ , $T_J = 25^\circ\text{C}$		0.75	1.2	A
$I_{scp}$	Short circuit peak current	$T_J = 25^\circ\text{C}$	1.3	2.2	3.3	A

1. Load and line regulation are specified at constant junction temperature. Changes in  $V_O$  due to heating effects must be taken into account separately. Pulse testing with low duty cycle is used.

**Table 11. Electrical characteristics of L7805C** (refer to the test circuits,  $T_J = -55$  to  $150^\circ\text{C}$ ,  $V_I = 10\text{V}$ ,  $I_O = 500\text{ mA}$ ,  $C_I = 0.33\ \mu\text{F}$ ,  $C_O = 0.1\ \mu\text{F}$  unless otherwise specified)

Symbol	Parameter	Test conditions	Min.	Typ.	Max.	Unit
$V_O$	Output voltage	$T_J = 25^\circ\text{C}$	4.8	5	5.2	V
$V_O$	Output voltage	$I_O = 5\text{mA to } 1\text{A}$ , $P_O \leq 15\text{W}$ $V_I = 7$ to $20\text{V}$	4.75	5	5.25	V
$\Delta V_O^{(1)}$	Line regulation	$V_I = 7$ to $25\text{V}$ , $T_J = 25^\circ\text{C}$		3	100	mV
		$V_I = 8$ to $12\text{V}$ , $T_J = 25^\circ\text{C}$		1	50	
$\Delta V_O^{(1)}$	Load regulation	$I_O = 5\text{ mA to } 1.5\text{A}$ , $T_J = 25^\circ\text{C}$			100	mV
		$I_O = 250$ to $750\text{mA}$ , $T_J = 25^\circ\text{C}$			50	
$I_d$	Quiescent current	$T_J = 25^\circ\text{C}$			8	mA
$\Delta I_d$	Quiescent current change	$I_O = 5\text{mA to } 1\text{A}$			0.5	mA
		$V_I = 7$ to $25\text{ V}$			0.8	
$\Delta V_O/\Delta T$	Output voltage drift	$I_O = 5\text{mA}$		-1.1		mV/ $^\circ\text{C}$
eN	Output noise voltage	$B = 10\text{Hz to } 100\text{KHz}$ , $T_J = 25^\circ\text{C}$		40		$\mu\text{V}/V_O$
SVR	Supply voltage rejection	$V_I = 8$ to $18\text{V}$ , $f = 120\text{Hz}$	62			dB
$V_d$	Dropout voltage	$I_O = 1\text{A}$ , $T_J = 25^\circ\text{C}$		2		V
$R_O$	Output resistance	$f = 1\text{ KHz}$		17		m $\Omega$
$I_{sc}$	Short circuit current	$V_I = 35\text{V}$ , $T_J = 25^\circ\text{C}$		0.75		A
$I_{scp}$	Short circuit peak current	$T_J = 25^\circ\text{C}$		2.2		A

1. Load and line regulation are specified at constant junction temperature. Changes in  $V_O$  due to heating effects must be taken into account separately. Pulse testing with low duty cycle is used.

**Table 12. Electrical characteristics of L7852C** (refer to the test circuits,  $T_J = -55$  to  $150^\circ\text{C}$ ,  $V_I = 10\text{V}$ ,  $I_O = 500\text{ mA}$ ,  $C_I = 0.33\text{ }\mu\text{F}$ ,  $C_O = 0.1\text{ }\mu\text{F}$  unless otherwise specified)

Symbol	Parameter	Test conditions	Min.	Typ.	Max.	Unit
$V_O$	Output voltage	$T_J = 25^\circ\text{C}$	5.0	5.2	5.4	V
$V_O$	Output voltage	$I_O = 5\text{mA to }1\text{A}$ , $P_O \leq 15\text{W}$ $V_I = 8$ to $20\text{V}$	4.95	5.2	5.45	V
$\Delta V_O^{(1)}$	Line regulation	$V_I = 7$ to $25\text{V}$ , $T_J = 25^\circ\text{C}$		3	105	mV
		$V_I = 8$ to $12\text{V}$ , $T_J = 25^\circ\text{C}$		1	52	
$\Delta V_O^{(1)}$	Load regulation	$I_O = 5\text{ mA to }1.5\text{A}$ , $T_J = 25^\circ\text{C}$			105	mV
		$I_O = 250$ to $750\text{mA}$ , $T_J = 25^\circ\text{C}$			52	
$I_d$	Quiescent current	$T_J = 25^\circ\text{C}$			8	mA
$\Delta I_d$	Quiescent current change	$I_O = 5\text{mA to }1\text{A}$			0.5	mA
		$V_I = 7$ to $25\text{ V}$			1.3	
$\Delta V_O/\Delta T$	Output voltage drift	$I_O = 5\text{mA}$		-1		mV/ $^\circ\text{C}$
eN	Output noise voltage	$B = 10\text{Hz to }100\text{KHz}$ , $T_J = 25^\circ\text{C}$		42		$\mu\text{V}/V_O$
SVR	Supply voltage rejection	$V_I = 8$ to $18\text{V}$ , $f = 120\text{Hz}$	61			dB
$V_d$	Dropout voltage	$I_O = 1\text{A}$ , $T_J = 25^\circ\text{C}$		2		V
$R_O$	Output resistance	$f = 1\text{ KHz}$		17		m $\Omega$
$I_{sc}$	Short circuit current	$V_I = 35\text{V}$ , $T_J = 25^\circ\text{C}$		0.75		A
$I_{scp}$	Short circuit peak current	$T_J = 25^\circ\text{C}$		2.2		A

1. Load and line regulation are specified at constant junction temperature. Changes in  $V_O$  due to heating effects must be taken into account separately. Pulse testing with low duty cycle is used.

**Table 13. Electrical characteristics of L7806C** (refer to the test circuits,  $T_J = -55$  to  $150^\circ\text{C}$ ,  $V_I = 11\text{V}$ ,  $I_O = 500\text{ mA}$ ,  $C_I = 0.33\ \mu\text{F}$ ,  $C_O = 0.1\ \mu\text{F}$  unless otherwise specified)

Symbol	Parameter	Test conditions	Min.	Typ.	Max.	Unit
$V_O$	Output voltage	$T_J = 25^\circ\text{C}$	5.75	6	6.25	V
$V_O$	Output voltage	$I_O = 5\text{mA to } 1\text{A}$ , $P_O \leq 15\text{W}$ $V_I = 8$ to $21\text{V}$	5.7	6	6.3	V
$\Delta V_O^{(1)}$	Line regulation	$V_I = 8$ to $25\text{V}$ , $T_J = 25^\circ\text{C}$			120	mV
		$V_I = 9$ to $13\text{V}$ , $T_J = 25^\circ\text{C}$			60	
$\Delta V_O^{(1)}$	Load regulation	$I_O = 5\text{ mA to } 1.5\text{A}$ , $T_J = 25^\circ\text{C}$			120	mV
		$I_O = 250$ to $750\text{mA}$ , $T_J = 25^\circ\text{C}$			60	
$I_d$	Quiescent current	$T_J = 25^\circ\text{C}$			8	mA
$\Delta I_d$	Quiescent current change	$I_O = 5\text{mA to } 1\text{A}$			0.5	mA
		$V_I = 8$ to $25\text{V}$			1.3	
$\Delta V_O/\Delta T$	Output voltage drift	$I_O = 5\text{mA}$		-0.8		mV/ $^\circ\text{C}$
eN	Output noise voltage	$B = 10\text{Hz to } 100\text{KHz}$ , $T_J = 25^\circ\text{C}$		45		$\mu\text{V}/V_O$
SVR	Supply voltage rejection	$V_I = 9$ to $19\text{V}$ , $f = 120\text{Hz}$	59			dB
$V_d$	Dropout voltage	$I_O = 1\text{A}$ , $T_J = 25^\circ\text{C}$		2		V
$R_O$	Output resistance	$f = 1\text{ KHz}$		19		m $\Omega$
$I_{sc}$	Short circuit current	$V_I = 35\text{V}$ , $T_J = 25^\circ\text{C}$		0.55		A
$I_{scp}$	Short circuit peak current	$T_J = 25^\circ\text{C}$		2.2		A

1. Load and line regulation are specified at constant junction temperature. Changes in  $V_O$  due to heating effects must be taken into account separately. Pulse testing with low duty cycle is used.

**Table 14. Electrical characteristics of L7808C** (refer to the test circuits,  $T_J = -55$  to  $150^\circ\text{C}$ ,  $V_I = 14\text{V}$ ,  $I_O = 500\text{ mA}$ ,  $C_I = 0.33\text{ }\mu\text{F}$ ,  $C_O = 0.1\text{ }\mu\text{F}$  unless otherwise specified)

Symbol	Parameter	Test conditions	Min.	Typ.	Max.	Unit
$V_O$	Output voltage	$T_J = 25^\circ\text{C}$	7.7	8	8.3	V
$V_O$	Output voltage	$I_O = 5\text{mA to }1\text{A}$ , $P_O \leq 15\text{W}$ $V_I = 10.5$ to $25\text{V}$	7.6	8	8.4	V
$\Delta V_O^{(1)}$	Line regulation	$V_I = 10.5$ to $25\text{V}$ , $T_J = 25^\circ\text{C}$			160	mV
		$V_I = 11$ to $17\text{V}$ , $T_J = 25^\circ\text{C}$			80	
$\Delta V_O^{(1)}$	Load regulation	$I_O = 5\text{ mA to }1.5\text{A}$ , $T_J = 25^\circ\text{C}$			160	mV
		$I_O = 250$ to $750\text{mA}$ , $T_J = 25^\circ\text{C}$			80	
$I_d$	Quiescent current	$T_J = 25^\circ\text{C}$			8	mA
$\Delta I_d$	Quiescent current change	$I_O = 5\text{mA to }1\text{A}$			0.5	mA
		$V_I = 10.5$ to $25\text{V}$			1	
$\Delta V_O/\Delta T$	Output voltage drift	$I_O = 5\text{mA}$		-0.8		mV/ $^\circ\text{C}$
eN	Output noise voltage	$B = 10\text{Hz to }100\text{kHz}$ , $T_J = 25^\circ\text{C}$		52		$\mu\text{V}/V_O$
SVR	Supply voltage rejection	$V_I = 11.5$ to $21.5\text{V}$ , $f = 120\text{Hz}$	56			dB
$V_d$	Dropout voltage	$I_O = 1\text{A}$ , $T_J = 25^\circ\text{C}$		2		V
$R_O$	Output resistance	$f = 1\text{ KHz}$		16		m $\Omega$
$I_{sc}$	Short circuit current	$V_I = 35\text{V}$ , $T_J = 25^\circ\text{C}$		0.45		A
$I_{scp}$	Short circuit peak current	$T_J = 25^\circ\text{C}$		2.2		A

1. Load and line regulation are specified at constant junction temperature. Changes in  $V_O$  due to heating effects must be taken into account separately. Pulse testing with low duty cycle is used.

**Table 15. Electrical characteristics of L7885C** (refer to the test circuits,  $T_J = -55$  to  $150^\circ\text{C}$ ,  $V_I = 14.5\text{V}$ ,  $I_O = 500\text{ mA}$ ,  $C_I = 0.33\text{ }\mu\text{F}$ ,  $C_O = 0.1\text{ }\mu\text{F}$  unless otherwise specified)

Symbol	Parameter	Test conditions	Min.	Typ.	Max.	Unit
$V_O$	Output voltage	$T_J = 25^\circ\text{C}$	8.2	8.5	8.8	V
$V_O$	Output voltage	$I_O = 5\text{mA to }1\text{A}$ , $P_O \leq 15\text{W}$ $V_I = 11$ to $26\text{V}$	8.1	8.5	8.9	V
$\Delta V_O^{(1)}$	Line regulation	$V_I = 11$ to $27\text{V}$ , $T_J = 25^\circ\text{C}$			160	mV
		$V_I = 11.5$ to $17.5\text{V}$ , $T_J = 25^\circ\text{C}$			80	
$\Delta V_O^{(1)}$	Load regulation	$I_O = 5\text{ mA to }1.5\text{A}$ , $T_J = 25^\circ\text{C}$			160	mV
		$I_O = 250$ to $750\text{mA}$ , $T_J = 25^\circ\text{C}$			80	
$I_d$	Quiescent current	$T_J = 25^\circ\text{C}$			8	mA
$\Delta I_d$	Quiescent current change	$I_O = 5\text{mA to }1\text{A}$			0.5	mA
		$V_I = 11$ to $27\text{V}$			1	
$\Delta V_O/\Delta T$	Output voltage drift	$I_O = 5\text{mA}$		-0.8		mV/ $^\circ\text{C}$
eN	Output noise voltage	$B = 10\text{Hz to }100\text{KHz}$ , $T_J = 25^\circ\text{C}$		55		$\mu\text{V}/V_O$
SVR	Supply voltage rejection	$V_I = 12$ to $22\text{V}$ , $f = 120\text{Hz}$	56			dB
$V_d$	Dropout voltage	$I_O = 1\text{A}$ , $T_J = 25^\circ\text{C}$		2		V
$R_O$	Output resistance	$f = 1\text{ KHz}$		16		m $\Omega$
$I_{sc}$	Short circuit current	$V_I = 35\text{V}$ , $T_J = 25^\circ\text{C}$		0.45		A
$I_{scp}$	Short circuit peak current	$T_J = 25^\circ\text{C}$		2.2		A

1. Load and line regulation are specified at constant junction temperature. Changes in  $V_O$  due to heating effects must be taken into account separately. Pulse testing with low duty cycle is used.

**Table 16. Electrical characteristics of L7809C** (refer to the test circuits,  $T_J = -55$  to  $150^\circ\text{C}$ ,  $V_I = 15\text{V}$ ,  $I_O = 500\text{ mA}$ ,  $C_I = 0.33\text{ }\mu\text{F}$ ,  $C_O = 0.1\text{ }\mu\text{F}$  unless otherwise specified)

Symbol	Parameter	Test conditions	Min.	Typ.	Max.	Unit
$V_O$	Output voltage	$T_J = 25^\circ\text{C}$	8.64	9	9.36	V
$V_O$	Output voltage	$I_O = 5\text{mA to } 1\text{A}$ , $P_O \leq 15\text{W}$ $V_I = 11.5$ to $26\text{V}$	8.55	9	9.45	V
$\Delta V_O^{(1)}$	Line regulation	$V_I = 11.5$ to $26\text{V}$ , $T_J = 25^\circ\text{C}$			180	mV
		$V_I = 12$ to $18\text{V}$ , $T_J = 25^\circ\text{C}$			90	
$\Delta V_O^{(1)}$	Load regulation	$I_O = 5\text{ mA to } 1.5\text{A}$ , $T_J = 25^\circ\text{C}$			180	mV
		$I_O = 250$ to $750\text{mA}$ , $T_J = 25^\circ\text{C}$			90	
$I_d$	Quiescent current	$T_J = 25^\circ\text{C}$			8	mA
$\Delta I_d$	Quiescent current change	$I_O = 5\text{mA to } 1\text{A}$			0.5	mA
		$V_I = 11.5$ to $26\text{V}$			1	
$\Delta V_O/\Delta T$	Output voltage drift	$I_O = 5\text{mA}$		-1		mV/ $^\circ\text{C}$
eN	Output noise voltage	$B = 10\text{Hz to } 100\text{kHz}$ , $T_J = 25^\circ\text{C}$		70		$\mu\text{V}/V_O$
SVR	Supply voltage rejection	$V_I = 12$ to $23\text{V}$ , $f = 120\text{Hz}$	55			dB
$V_d$	Dropout voltage	$I_O = 1\text{A}$ , $T_J = 25^\circ\text{C}$		2		V
$R_O$	Output resistance	$f = 1\text{ KHz}$		17		m $\Omega$
$I_{sc}$	Short circuit current	$V_I = 35\text{V}$ , $T_J = 25^\circ\text{C}$		0.40		A
$I_{scp}$	Short circuit peak current	$T_J = 25^\circ\text{C}$		2.2		A

1. Load and line regulation are specified at constant junction temperature. Changes in  $V_O$  due to heating effects must be taken into account separately. Pulse testing with low duty cycle is used.

**Table 17. Electrical characteristics of L7810C** (refer to the test circuits,  $T_J = -55$  to  $150^\circ\text{C}$ ,  $V_I = 15\text{V}$ ,  $I_O = 500\text{ mA}$ ,  $C_I = 0.33\ \mu\text{F}$ ,  $C_O = 0.1\ \mu\text{F}$  unless otherwise specified)

Symbol	Parameter	Test conditions	Min.	Typ.	Max.	Unit
$V_O$	Output voltage	$T_J = 25^\circ\text{C}$	9.6	10	10.4	V
$V_O$	Output voltage	$I_O = 5\text{mA to } 1\text{A}$ , $P_O \leq 15\text{W}$ $V_I = 12.5$ to $26\text{V}$	9.5	10	10.5	V
$\Delta V_O^{(1)}$	Line regulation	$V_I = 12.5$ to $26\text{V}$ , $T_J = 25^\circ\text{C}$			200	mV
		$V_I = 13.5$ to $19\text{V}$ , $T_J = 25^\circ\text{C}$			100	
$\Delta V_O^{(1)}$	Load regulation	$I_O = 5\text{ mA to } 1.5\text{A}$ , $T_J = 25^\circ\text{C}$			200	mV
		$I_O = 250$ to $750\text{mA}$ , $T_J = 25^\circ\text{C}$			100	
$I_d$	Quiescent current	$T_J = 25^\circ\text{C}$			8	mA
$\Delta I_d$	Quiescent current change	$I_O = 5\text{mA to } 1\text{A}$			0.5	mA
		$V_I = 12.5$ to $26\text{V}$			1	
$\Delta V_O/\Delta T$	Output voltage drift	$I_O = 5\text{mA}$		-1		mV/ $^\circ\text{C}$
eN	Output noise voltage	$B = 10\text{Hz to } 100\text{KHz}$ , $T_J = 25^\circ\text{C}$		70		$\mu\text{V}/V_O$
SVR	Supply voltage rejection	$V_I = 13$ to $23\text{V}$ , $f = 120\text{Hz}$	55			dB
$V_d$	Dropout voltage	$I_O = 1\text{A}$ , $T_J = 25^\circ\text{C}$		2		V
$R_O$	Output resistance	$f = 1\text{ KHz}$		17		m $\Omega$
$I_{sc}$	Short circuit current	$V_I = 35\text{V}$ , $T_J = 25^\circ\text{C}$		0.40		A
$I_{scp}$	Short circuit peak current	$T_J = 25^\circ\text{C}$		2.2		A

1. Load and line regulation are specified at constant junction temperature. Changes in  $V_O$  due to heating effects must be taken into account separately. Pulse testing with low duty cycle is used.

**Table 18. Electrical characteristics of L7812C** (refer to the test circuits,  $T_J = -55$  to  $150^\circ\text{C}$ ,  $V_I = 19\text{V}$ ,  $I_O = 500\text{ mA}$ ,  $C_I = 0.33\text{ }\mu\text{F}$ ,  $C_O = 0.1\text{ }\mu\text{F}$  unless otherwise specified)

Symbol	Parameter	Test conditions	Min.	Typ.	Max.	Unit
$V_O$	Output voltage	$T_J = 25^\circ\text{C}$	11.5	12	12.5	V
$V_O$	Output voltage	$I_O = 5\text{mA to } 1\text{A}$ , $P_O \leq 15\text{W}$ $V_I = 14.5$ to $27\text{V}$	11.4	12	12.6	V
$\Delta V_O^{(1)}$	Line regulation	$V_I = 14.5$ to $30\text{V}$ , $T_J = 25^\circ\text{C}$			240	mV
		$V_I = 16$ to $22\text{V}$ , $T_J = 25^\circ\text{C}$			120	
$\Delta V_O^{(1)}$	Load regulation	$I_O = 5\text{ mA to } 1.5\text{A}$ , $T_J = 25^\circ\text{C}$			240	mV
		$I_O = 250$ to $750\text{mA}$ , $T_J = 25^\circ\text{C}$			120	
$I_d$	Quiescent current	$T_J = 25^\circ\text{C}$			8	mA
$\Delta I_d$	Quiescent current change	$I_O = 5\text{mA to } 1\text{A}$			0.5	mA
		$V_I = 14.5$ to $30\text{V}$			1	
$\Delta V_O/\Delta T$	Output voltage drift	$I_O = 5\text{mA}$		-1		mV/ $^\circ\text{C}$
eN	Output noise voltage	$B = 10\text{Hz to } 100\text{KHz}$ , $T_J = 25^\circ\text{C}$		75		$\mu\text{V}/V_O$
SVR	Supply voltage rejection	$V_I = 15$ to $25\text{V}$ , $f = 120\text{Hz}$	55			dB
$V_d$	Dropout voltage	$I_O = 1\text{A}$ , $T_J = 25^\circ\text{C}$		2		V
$R_O$	Output resistance	$f = 1\text{ KHz}$		18		m $\Omega$
$I_{sc}$	Short circuit current	$V_I = 35\text{V}$ , $T_J = 25^\circ\text{C}$		0.35		A
$I_{scp}$	Short circuit peak current	$T_J = 25^\circ\text{C}$		2.2		A

1. Load and line regulation are specified at constant junction temperature. Changes in  $V_O$  due to heating effects must be taken into account separately. Pulse testing with low duty cycle is used.

**Table 19. Electrical characteristics of L7815C** (refer to the test circuits,  $T_J = -55$  to  $150^\circ\text{C}$ ,  $V_I = 23\text{V}$ ,  $I_O = 500\text{ mA}$ ,  $C_I = 0.33\ \mu\text{F}$ ,  $C_O = 0.1\ \mu\text{F}$  unless otherwise specified)

Symbol	Parameter	Test conditions	Min.	Typ.	Max.	Unit
$V_O$	Output voltage	$T_J = 25^\circ\text{C}$	14.5	15	15.6	V
$V_O$	Output voltage	$I_O = 5\text{mA to } 1\text{A}$ , $P_O \leq 15\text{W}$ $V_I = 17.5$ to $30\text{V}$	14.25	15	15.75	V
$\Delta V_O^{(1)}$	Line regulation	$V_I = 17.5$ to $30\text{V}$ , $T_J = 25^\circ\text{C}$			300	mV
		$V_I = 20$ to $26\text{V}$ , $T_J = 25^\circ\text{C}$			150	
$\Delta V_O^{(1)}$	Load regulation	$I_O = 5\text{ mA to } 1.5\text{A}$ , $T_J = 25^\circ\text{C}$			300	mV
		$I_O = 250$ to $750\text{mA}$ , $T_J = 25^\circ\text{C}$			150	
$I_d$	Quiescent current	$T_J = 25^\circ\text{C}$			8	mA
$\Delta I_d$	Quiescent current change	$I_O = 5\text{mA to } 1\text{A}$			0.5	mA
		$V_I = 17.5$ to $30\text{V}$			1	
$\Delta V_O/\Delta T$	Output voltage drift	$I_O = 5\text{mA}$		-1		mV/ $^\circ\text{C}$
eN	Output noise voltage	$B = 10\text{Hz to } 100\text{KHz}$ , $T_J = 25^\circ\text{C}$		90		$\mu\text{V}/V_O$
SVR	Supply voltage rejection	$V_I = 18.5$ to $28.5\text{V}$ , $f = 120\text{Hz}$	54			dB
$V_d$	Dropout voltage	$I_O = 1\text{A}$ , $T_J = 25^\circ\text{C}$		2		V
$R_O$	Output resistance	$f = 1\text{ KHz}$		19		m $\Omega$
$I_{sc}$	Short circuit current	$V_I = 35\text{V}$ , $T_J = 25^\circ\text{C}$		0.23		A
$I_{scp}$	Short circuit peak current	$T_J = 25^\circ\text{C}$		2.2		A

1. Load and line regulation are specified at constant junction temperature. Changes in  $V_O$  due to heating effects must be taken into account separately. Pulse testing with low duty cycle is used.

**Table 20. Electrical characteristics of L7818C** (refer to the test circuits,  $T_J = -55$  to  $150^\circ\text{C}$ ,  $V_I = 26\text{V}$ ,  $I_O = 500\text{ mA}$ ,  $C_I = 0.33\text{ }\mu\text{F}$ ,  $C_O = 0.1\text{ }\mu\text{F}$  unless otherwise specified)

Symbol	Parameter	Test conditions	Min.	Typ.	Max.	Unit
$V_O$	Output voltage	$T_J = 25^\circ\text{C}$	17.3	18	18.7	V
$V_O$	Output voltage	$I_O = 5\text{mA to } 1\text{A}$ , $P_O \leq 15\text{W}$ $V_I = 21$ to $33\text{V}$	17.1	18	18.9	V
$\Delta V_O^{(1)}$	Line regulation	$V_I = 21$ to $33\text{V}$ , $T_J = 25^\circ\text{C}$			360	mV
		$V_I = 24$ to $30\text{V}$ , $T_J = 25^\circ\text{C}$			180	
$\Delta V_O^{(1)}$	Load regulation	$I_O = 5\text{ mA to } 1.5\text{A}$ , $T_J = 25^\circ\text{C}$			360	mV
		$I_O = 250$ to $750\text{mA}$ , $T_J = 25^\circ\text{C}$			180	
$I_d$	Quiescent current	$T_J = 25^\circ\text{C}$			8	mA
$\Delta I_d$	Quiescent current change	$I_O = 5\text{mA to } 1\text{A}$			0.5	mA
		$V_I = 21$ to $33\text{V}$			1	
$\Delta V_O/\Delta T$	Output voltage drift	$I_O = 5\text{mA}$		-1		mV/ $^\circ\text{C}$
eN	Output noise voltage	$B = 10\text{Hz to } 100\text{KHz}$ , $T_J = 25^\circ\text{C}$		110		$\mu\text{V}/V_O$
SVR	Supply voltage rejection	$V_I = 22$ to $32\text{V}$ , $f = 120\text{Hz}$	53			dB
$V_d$	Dropout voltage	$I_O = 1\text{A}$ , $T_J = 25^\circ\text{C}$		2		V
$R_O$	Output resistance	$f = 1\text{ KHz}$		22		m $\Omega$
$I_{sc}$	Short circuit current	$V_I = 35\text{V}$ , $T_J = 25^\circ\text{C}$		0.20		A
$I_{scp}$	Short circuit peak current	$T_J = 25^\circ\text{C}$		2.1		A

1. Load and line regulation are specified at constant junction temperature. Changes in  $V_O$  due to heating effects must be taken into account separately. Pulse testing with low duty cycle is used.

**Table 21. Electrical characteristics of L7820C** (refer to the test circuits,  $T_J = -55$  to  $150^\circ\text{C}$ ,  $V_I = 28\text{V}$ ,  $I_O = 500\text{ mA}$ ,  $C_I = 0.33\ \mu\text{F}$ ,  $C_O = 0.1\ \mu\text{F}$  unless otherwise specified)

Symbol	Parameter	Test conditions	Min.	Typ.	Max.	Unit
$V_O$	Output voltage	$T_J = 25^\circ\text{C}$	19.2	20	20.8	V
$V_O$	Output voltage	$I_O = 5\text{mA to } 1\text{A}$ , $P_O \leq 15\text{W}$ $V_I = 23$ to $35\text{V}$	19	20	21	V
$\Delta V_O^{(1)}$	Line regulation	$V_I = 22.5$ to $35\text{V}$ , $T_J = 25^\circ\text{C}$			400	mV
		$V_I = 26$ to $32\text{V}$ , $T_J = 25^\circ\text{C}$			200	
$\Delta V_O^{(1)}$	Load regulation	$I_O = 5\text{ mA to } 1.5\text{A}$ , $T_J = 25^\circ\text{C}$			400	mV
		$I_O = 250$ to $750\text{mA}$ , $T_J = 25^\circ\text{C}$			200	
$I_d$	Quiescent current	$T_J = 25^\circ\text{C}$			8	mA
$\Delta I_d$	Quiescent current change	$I_O = 5\text{mA to } 1\text{A}$			0.5	mA
		$V_I = 23$ to $35\text{V}$			1	
$\Delta V_O/\Delta T$	Output voltage drift	$I_O = 5\text{mA}$		-1		mV/ $^\circ\text{C}$
eN	Output noise voltage	$B = 10\text{Hz to } 100\text{KHz}$ , $T_J = 25^\circ\text{C}$		150		$\mu\text{V}/V_O$
SVR	Supply voltage rejection	$V_I = 24$ to $35\text{V}$ , $f = 120\text{Hz}$	52			dB
$V_d$	Dropout voltage	$I_O = 1\text{A}$ , $T_J = 25^\circ\text{C}$		2		V
$R_O$	Output resistance	$f = 1\text{ KHz}$		24		m $\Omega$
$I_{sc}$	Short circuit current	$V_I = 35\text{V}$ , $T_J = 25^\circ\text{C}$		0.18		A
$I_{scp}$	Short circuit peak current	$T_J = 25^\circ\text{C}$		2.1		A

1. Load and line regulation are specified at constant junction temperature. Changes in  $V_O$  due to heating effects must be taken into account separately. Pulse testing with low duty cycle is used.

**Table 22. Electrical characteristics of L7824C** (refer to the test circuits,  $T_J = -55$  to  $150^\circ\text{C}$ ,  $V_I = 33\text{V}$ ,  $I_O = 500\text{ mA}$ ,  $C_I = 0.33\text{ }\mu\text{F}$ ,  $C_O = 0.1\text{ }\mu\text{F}$  unless otherwise specified)

Symbol	Parameter	Test conditions	Min.	Typ.	Max.	Unit
$V_O$	Output voltage	$T_J = 25^\circ\text{C}$	23	24	25	V
$V_O$	Output voltage	$I_O = 5\text{mA to } 1\text{A}$ , $P_O \leq 15\text{W}$ $V_I = 27$ to $38\text{V}$	22.8	24	25.2	V
$\Delta V_O^{(1)}$	Line regulation	$V_I = 27$ to $38\text{V}$ , $T_J = 25^\circ\text{C}$			480	mV
		$V_I = 30$ to $36\text{V}$ , $T_J = 25^\circ\text{C}$			240	
$\Delta V_O^{(1)}$	Load regulation	$I_O = 5\text{ mA to } 1.5\text{A}$ , $T_J = 25^\circ\text{C}$			480	mV
		$I_O = 250$ to $750\text{mA}$ , $T_J = 25^\circ\text{C}$			240	
$I_d$	Quiescent current	$T_J = 25^\circ\text{C}$			8	mA
$\Delta I_d$	Quiescent current change	$I_O = 5\text{mA to } 1\text{A}$			0.5	mA
		$V_I = 27$ to $38\text{V}$			1	
$\Delta V_O/\Delta T$	Output voltage drift	$I_O = 5\text{mA}$		-1.5		mV/ $^\circ\text{C}$
eN	Output noise voltage	$B = 10\text{Hz to } 100\text{kHz}$ , $T_J = 25^\circ\text{C}$		170		$\mu\text{V}/V_O$
SVR	Supply voltage rejection	$V_I = 28$ to $38\text{V}$ , $f = 120\text{Hz}$	50			dB
$V_d$	Dropout voltage	$I_O = 1\text{A}$ , $T_J = 25^\circ\text{C}$		2		V
$R_O$	Output resistance	$f = 1\text{ KHz}$		28		m $\Omega$
$I_{sc}$	Short circuit current	$V_I = 35\text{V}$ , $T_J = 25^\circ\text{C}$		0.15		A
$I_{scp}$	Short circuit peak current	$T_J = 25^\circ\text{C}$		2.1		A

1. Load and line regulation are specified at constant junction temperature. Changes in  $V_O$  due to heating effects must be taken into account separately. Pulse testing with low duty cycle is used.

# 5 Typical performance

Figure 7. Dropout voltage vs junction temperature

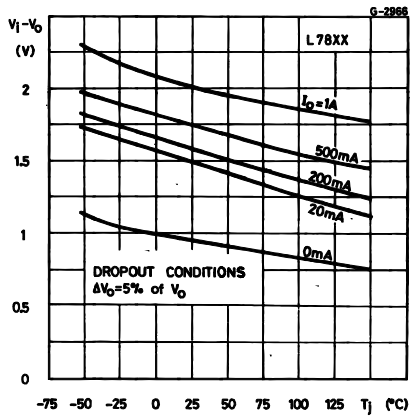

Figure 8. Peak output current vs input/output differential voltage

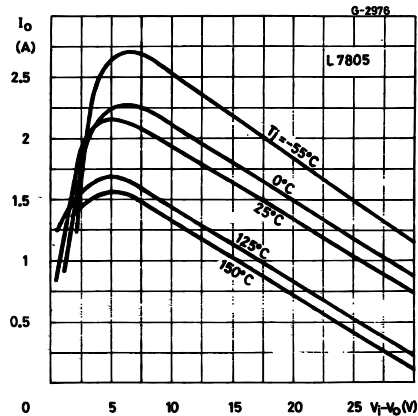

Figure 9. Supply voltage rejection vs frequency

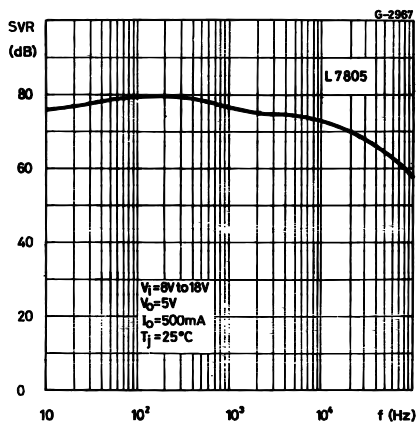

Figure 10. Output voltage vs junction temperature

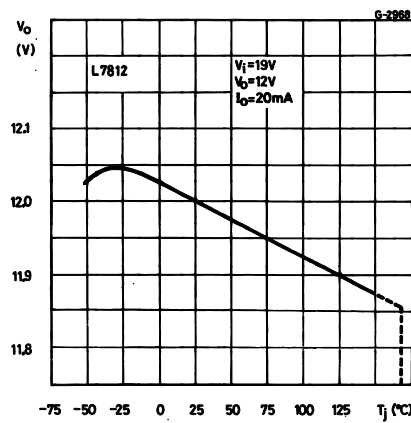

Figure 11. Output impedance vs frequency

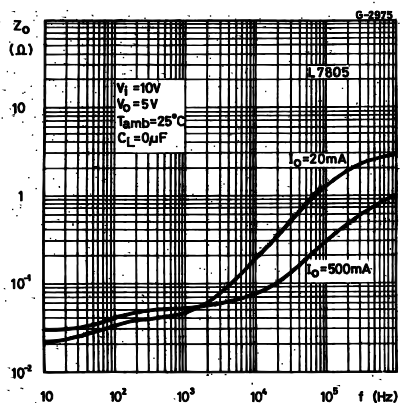

Figure 12. Quiescent current vs junction temperature

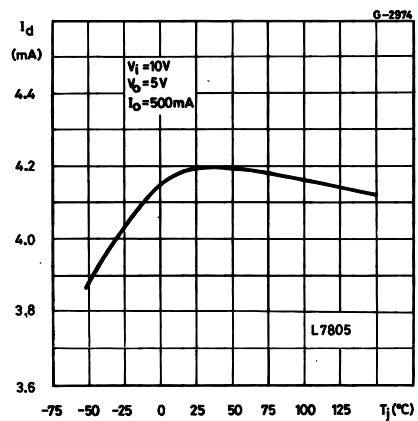

Figure 13. Load transient response

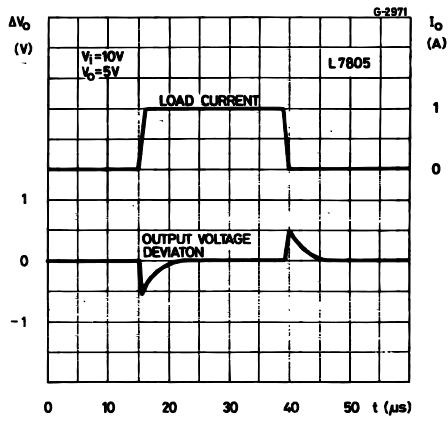

Figure 14. Line transient response

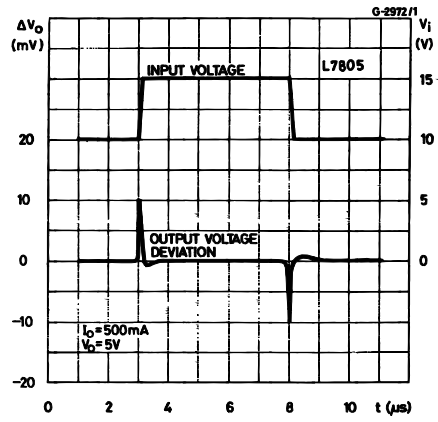

Figure 15. Quiescent current vs input voltage

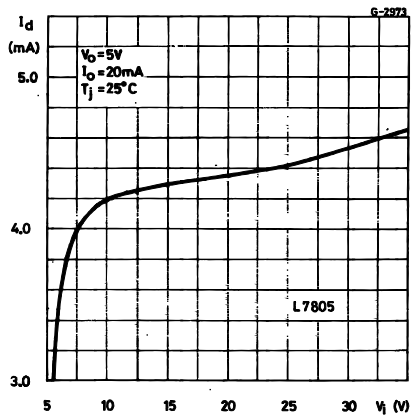
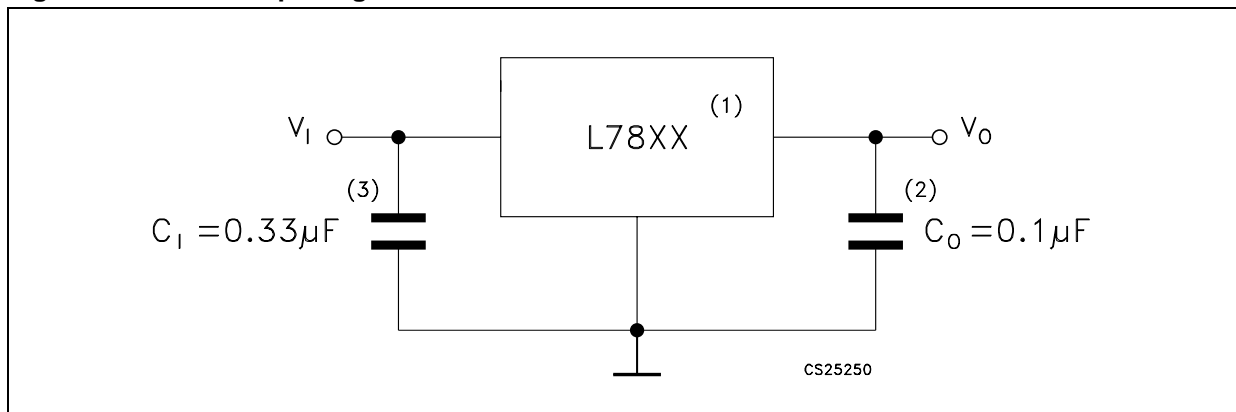

Figure 16. Fixed output regulator



1. To specify an output voltage, substitute voltage value for "XX".
2. Although no output capacitor is need for stability, it does improve transient response.
3. Required if regulator is locate an appreciable distance from power supply filter.

Figure 17. Current regulator

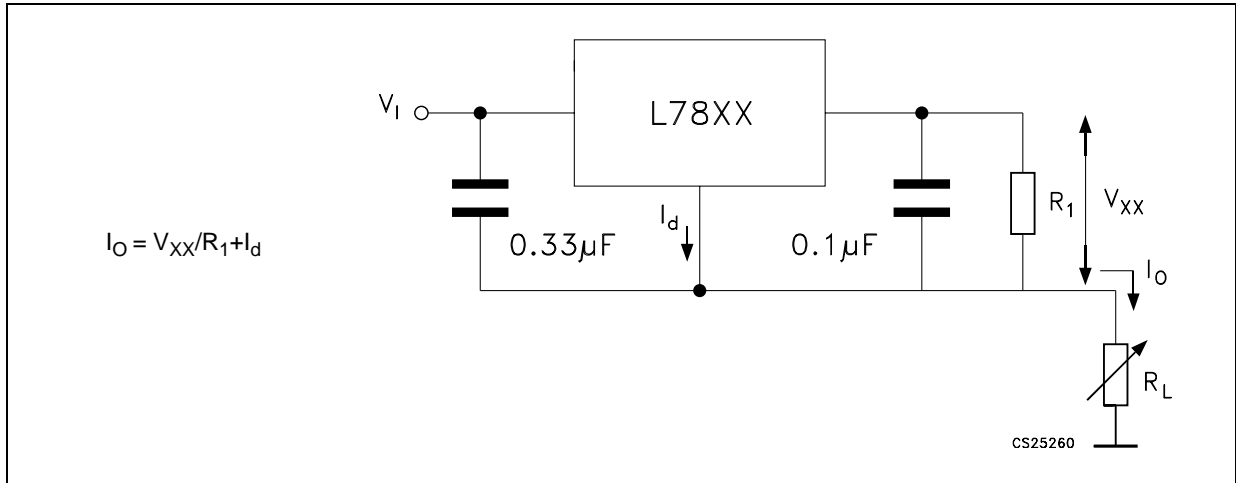

Figure 18. Circuit for increasing output voltage

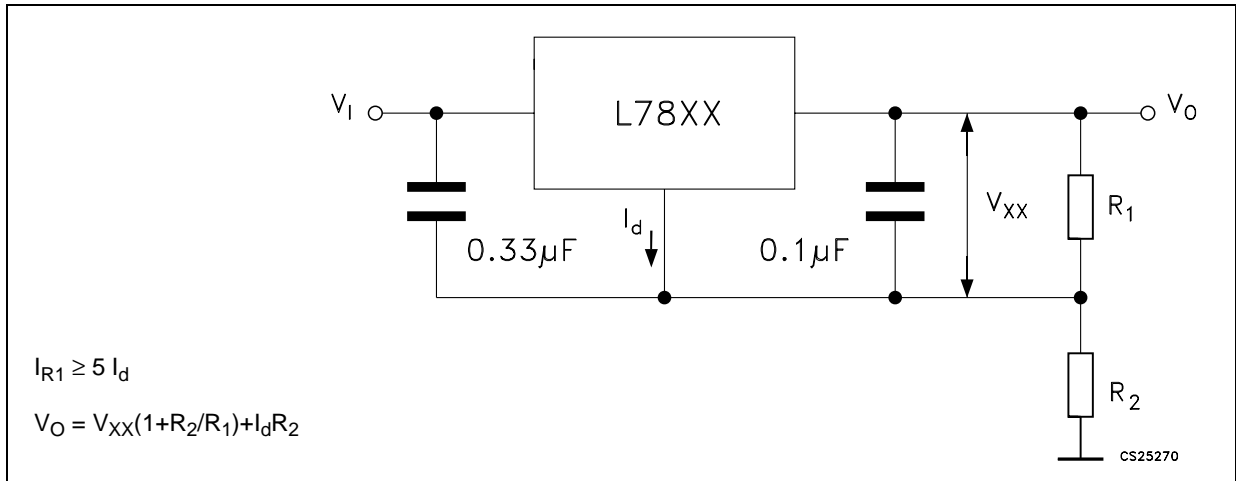

Figure 19. Adjustable output regulator (7 to 30V)

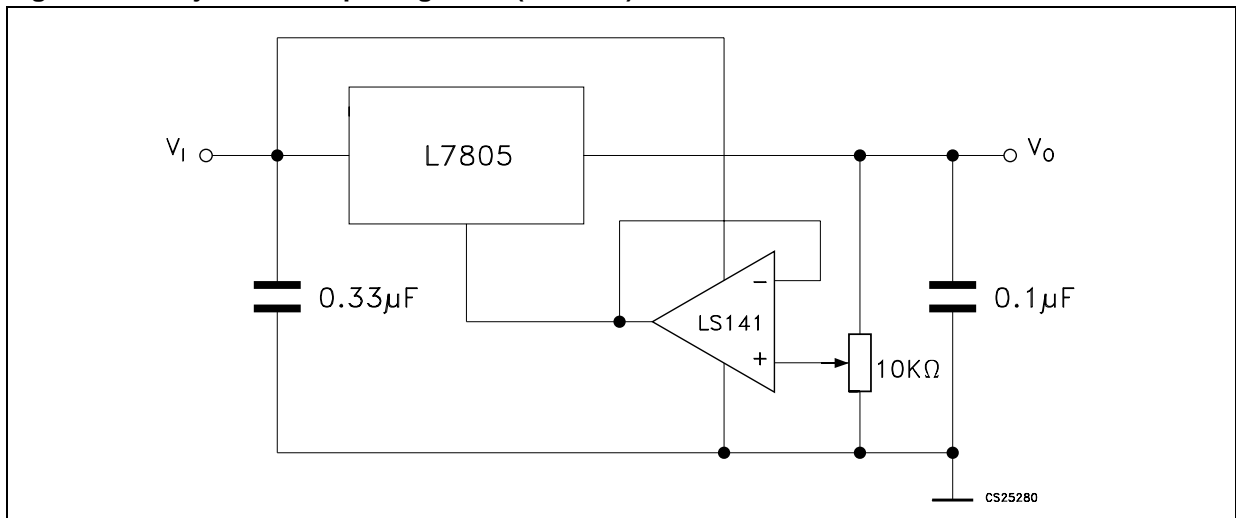

Figure 20. 0.5 to 10V Regulator

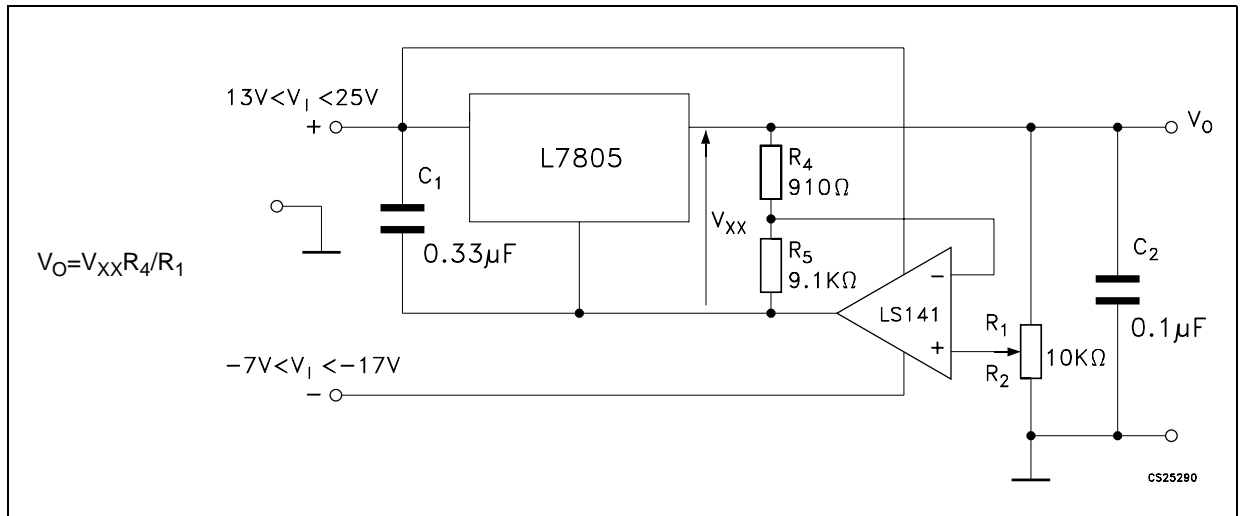

Figure 21. High current voltage regulator

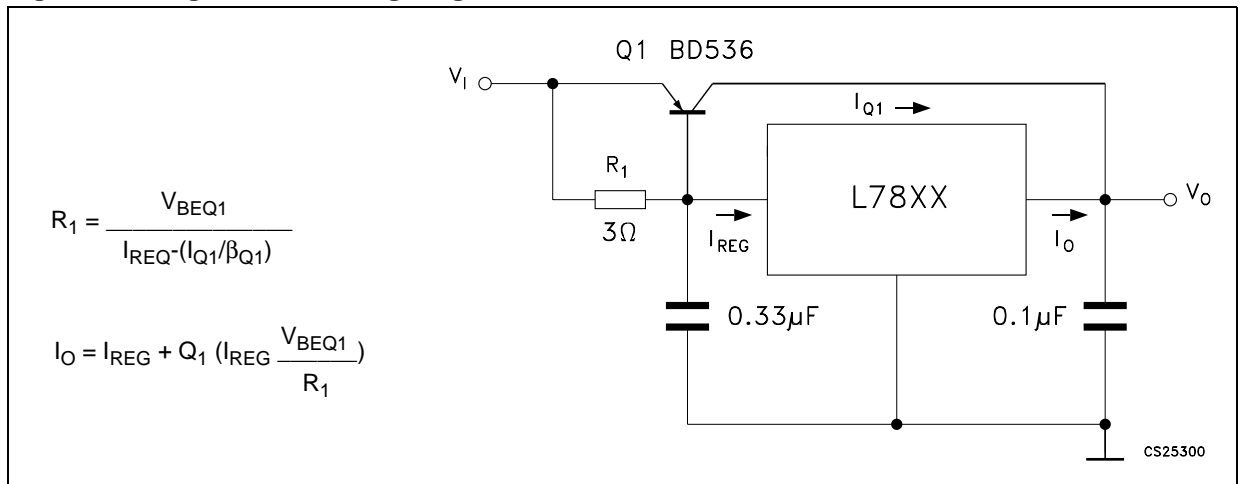

Figure 22. High output current with short circuit protection

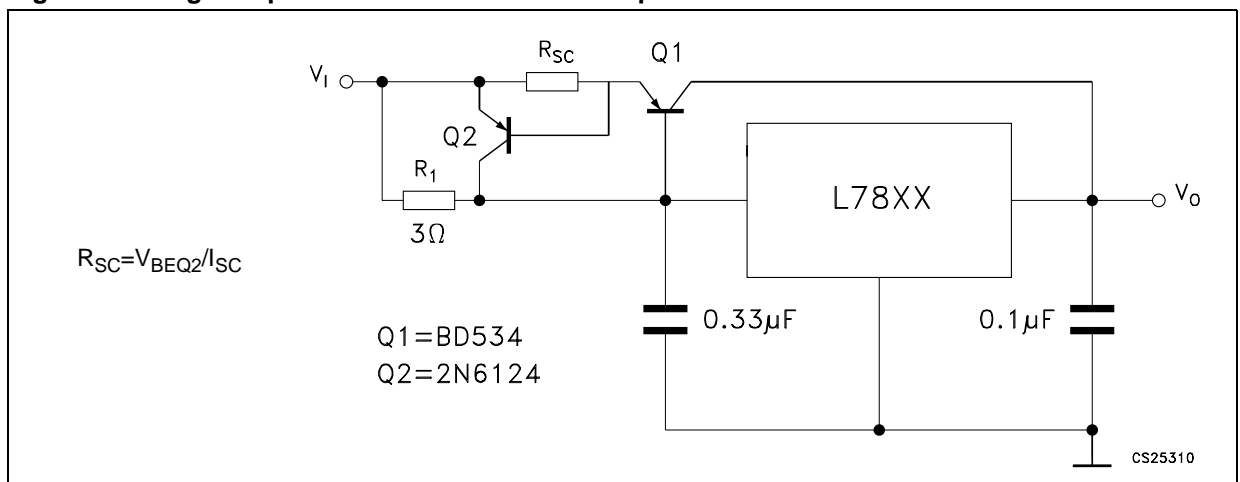

Figure 23. Tracking voltage regulator

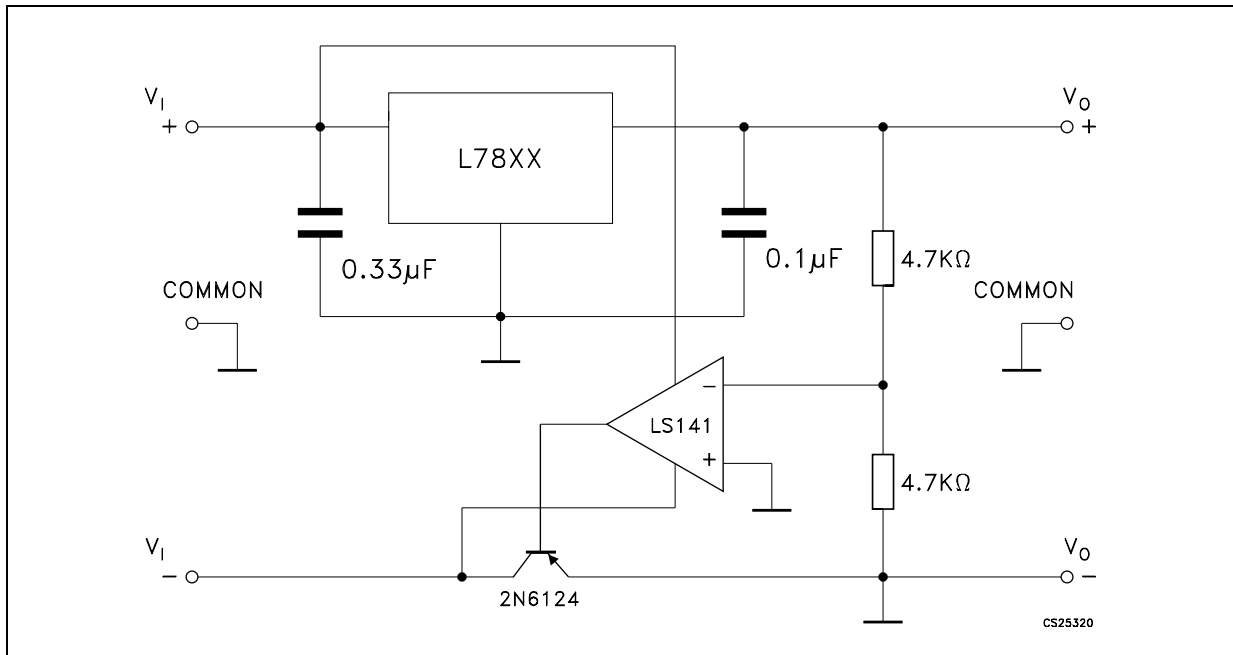
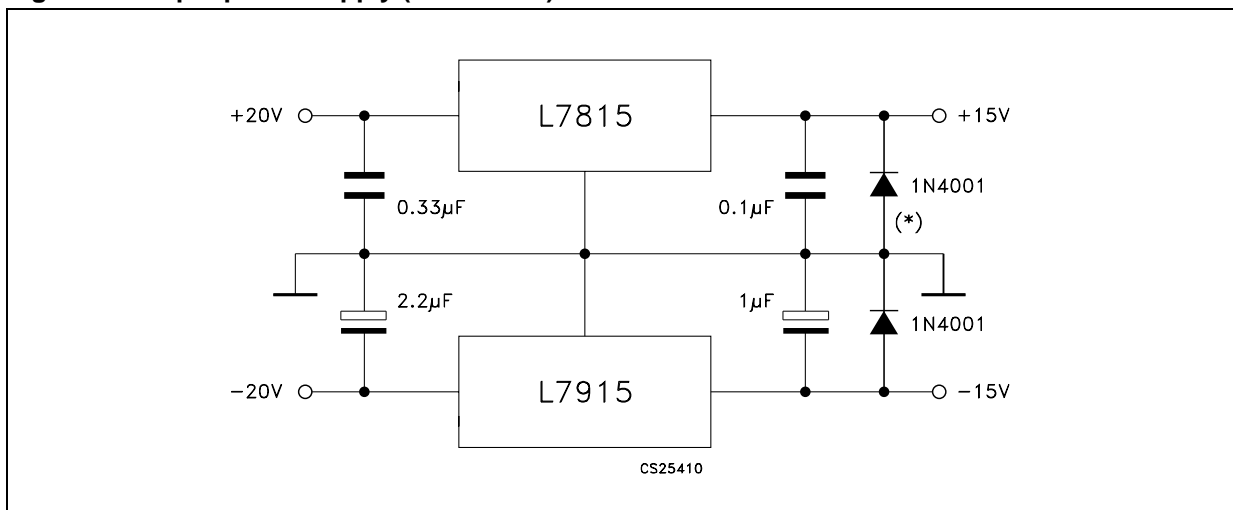

Figure 24. Split power supply ( $\pm 15\text{V} - 1\text{A}$ )



\* Against potential latch-up problems.

Figure 25. Negative output voltage circuit

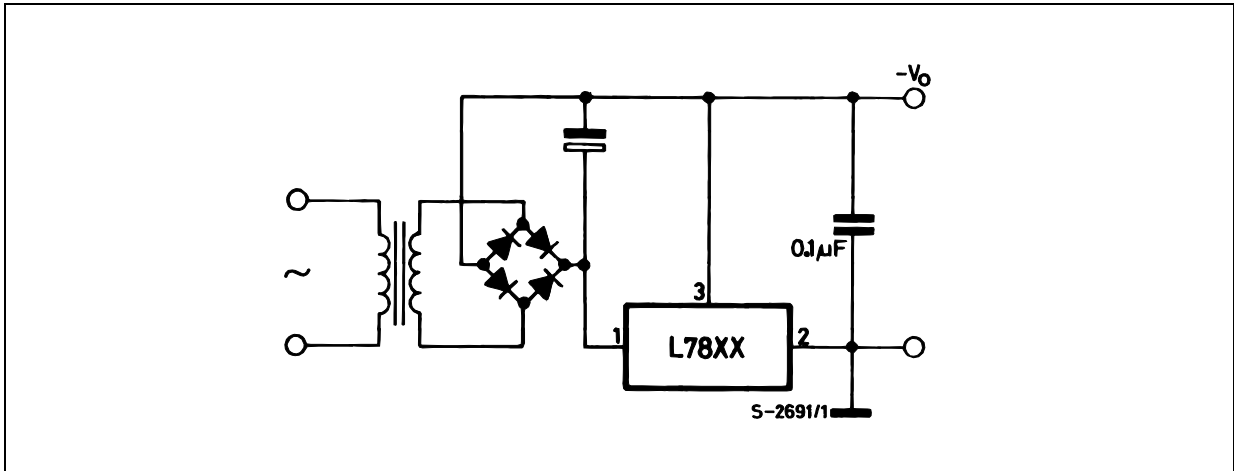

Figure 26. Switching regulator

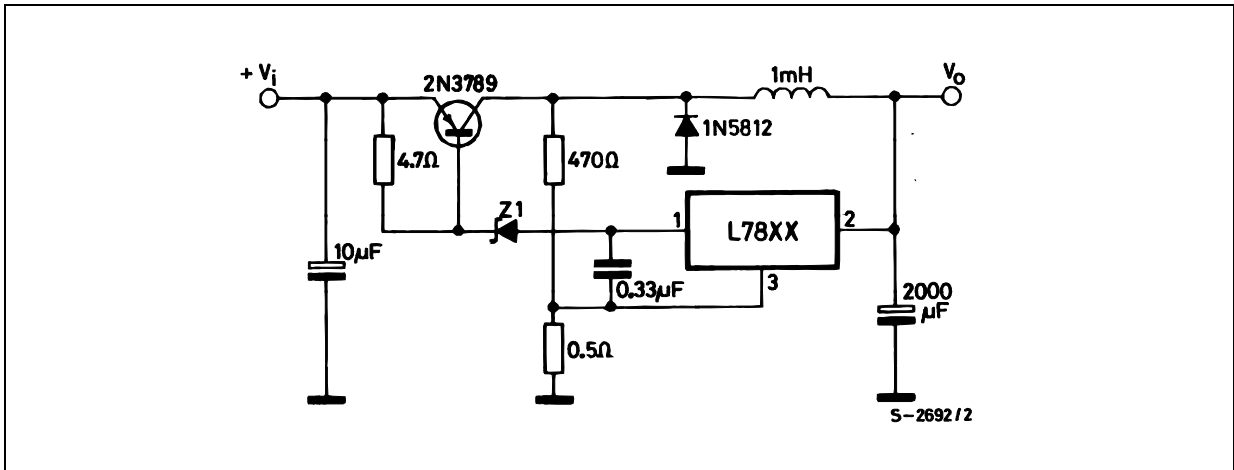

Figure 27. High input voltage circuit

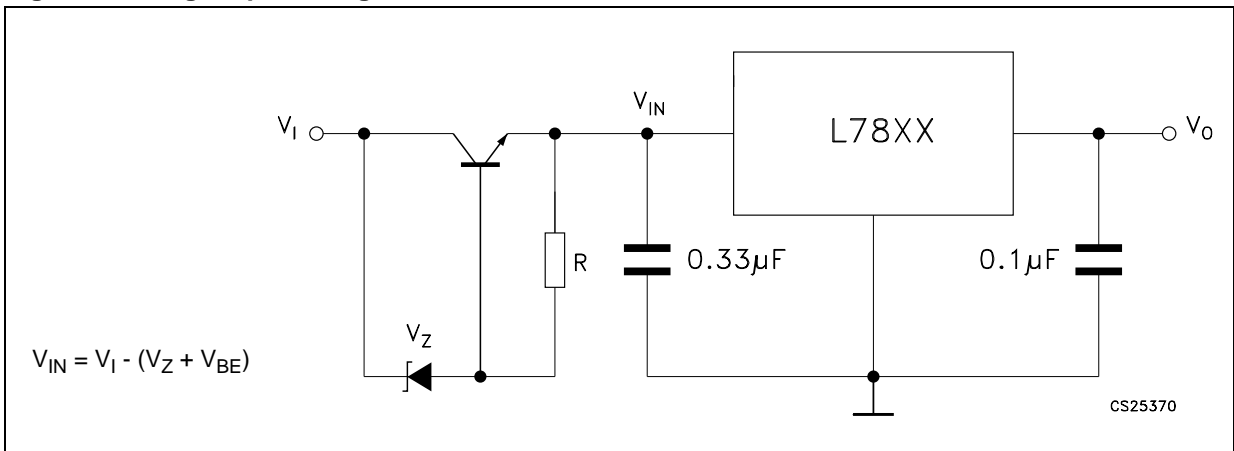

Figure 28. High input voltage circuit

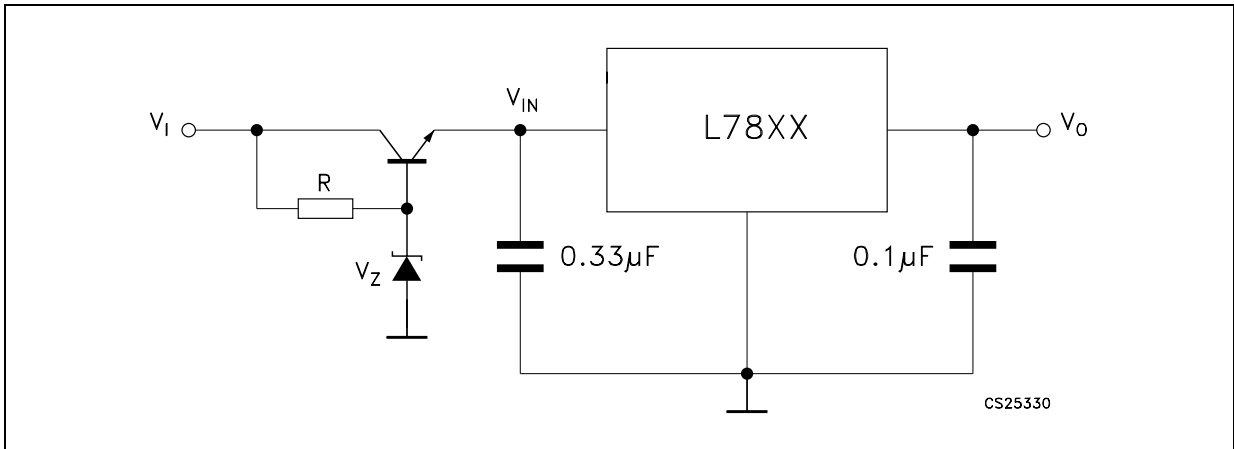

Figure 29. High output voltage regulator

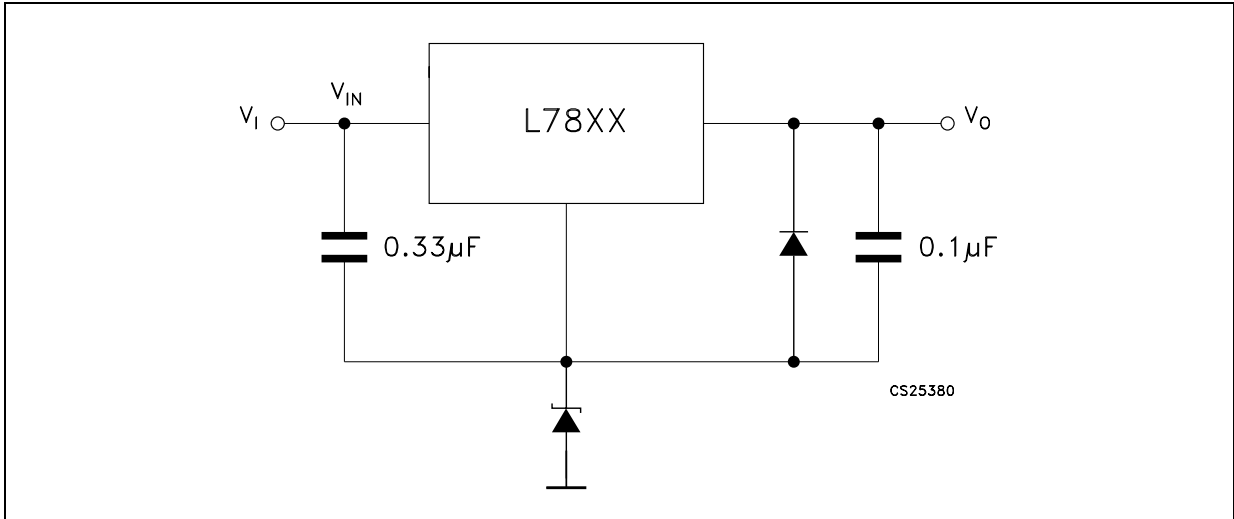

Figure 30. High input and output voltage

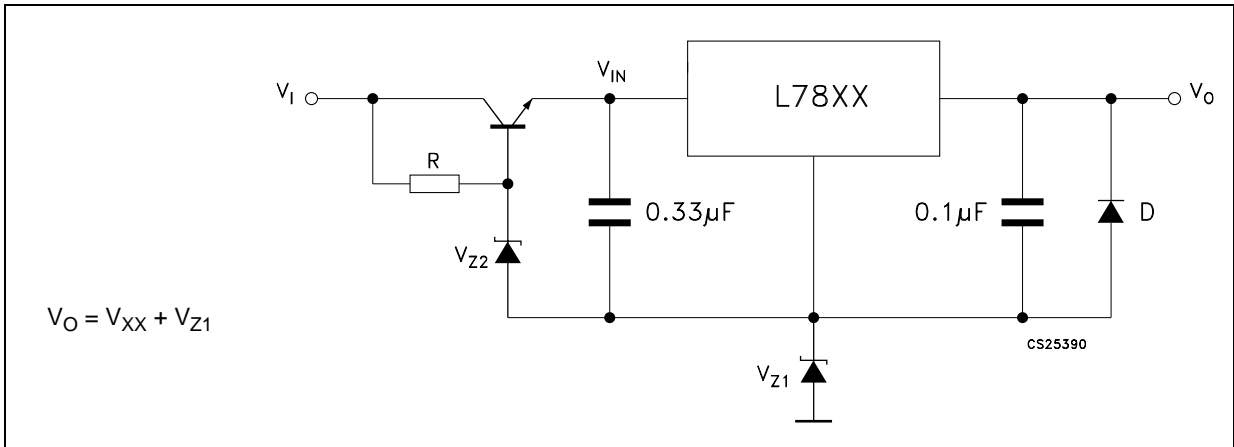

Figure 31. Reducing power dissipation with dropping resistor

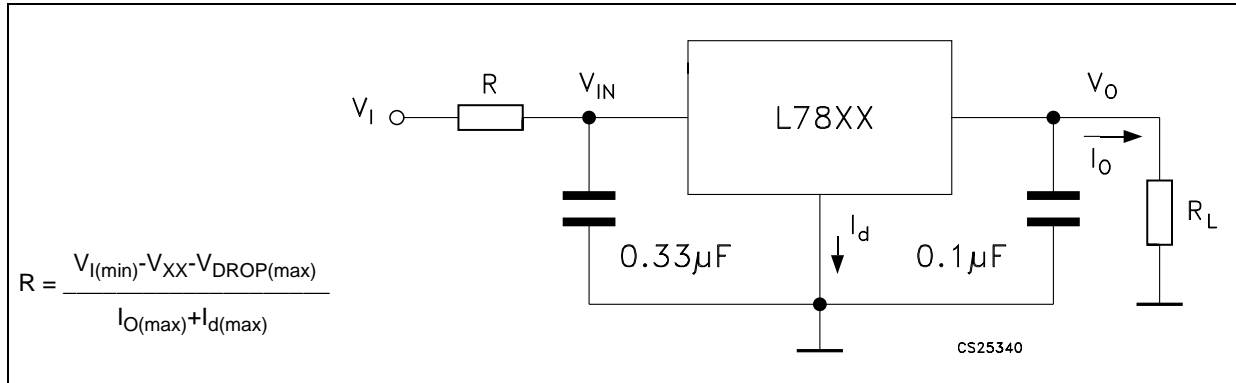

Figure 32. Remote shutdown

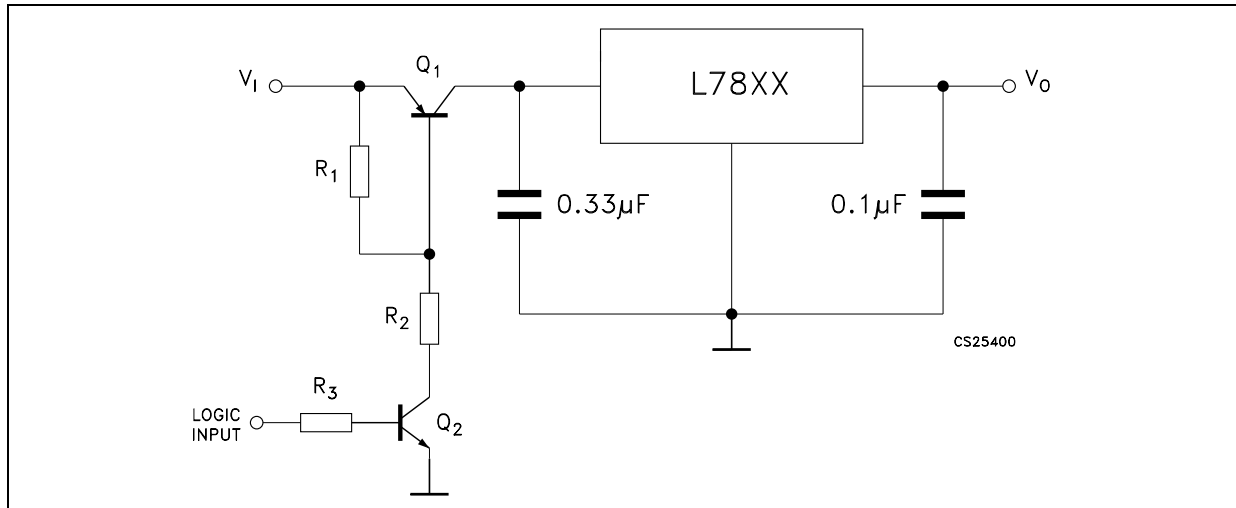
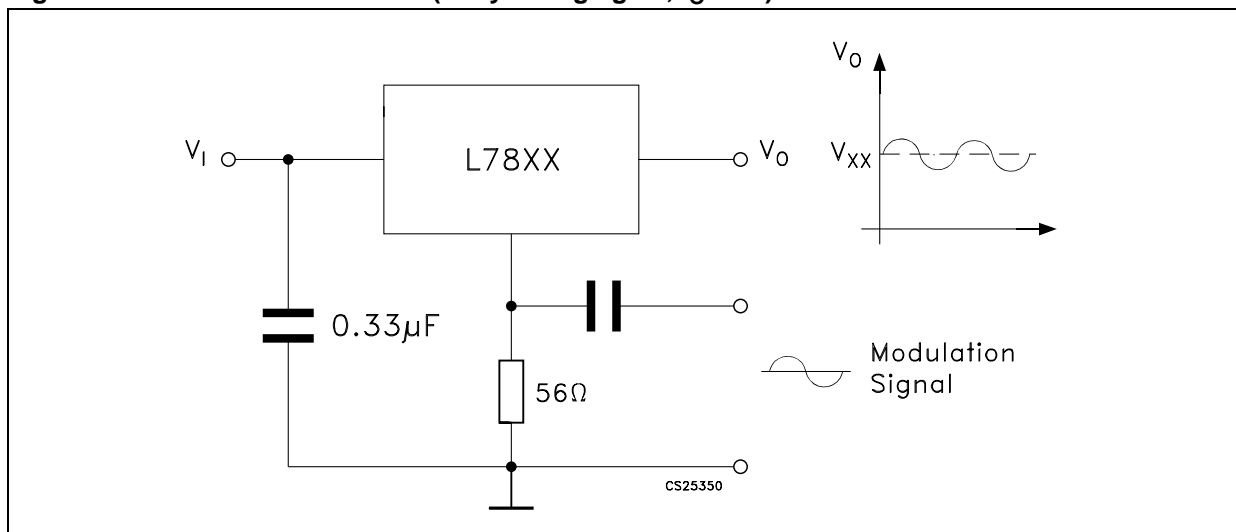
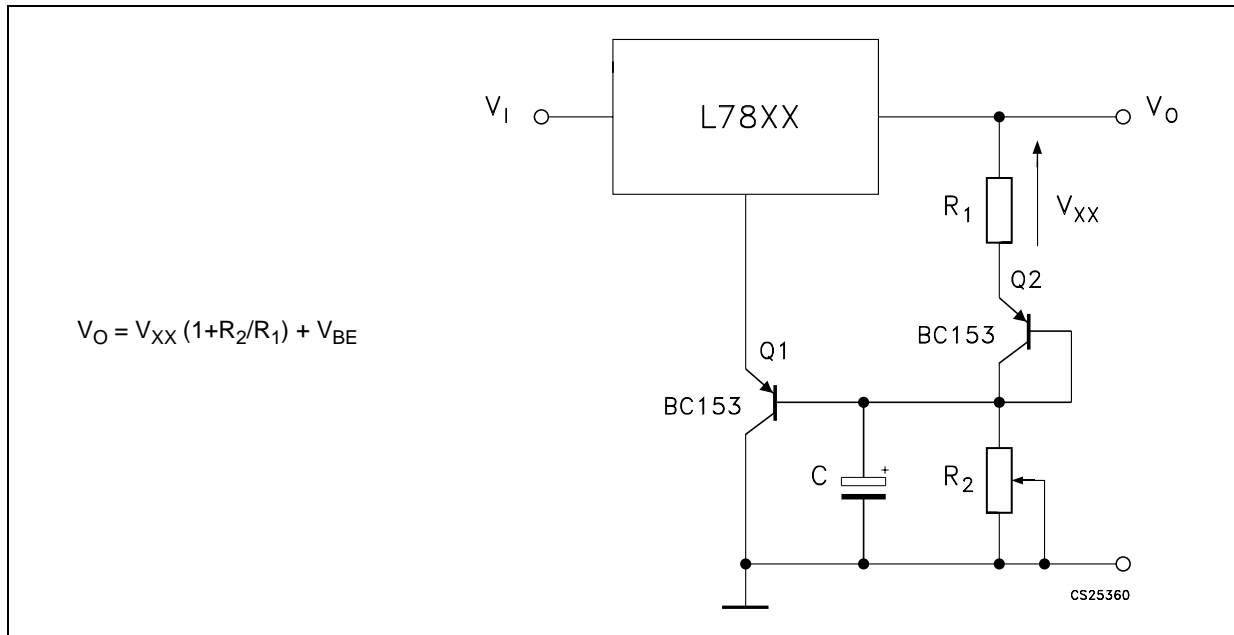

Figure 33. Power AM modulator (unity voltage gain,  $I_O \leq 0.5$ )



Note: The circuit performs well up to 100 KHz.

Figure 34. Adjustable output voltage with temperature compensation



Note:  $Q_2$  is connected as a diode in order to compensate the variation of the  $Q_1$   $V_{BE}$  with the temperature.  $C$  allows a slow rise time of the  $V_O$ .

Figure 35. Light controllers ( $V_{Omin} = V_{XX} + V_{BE}$ )

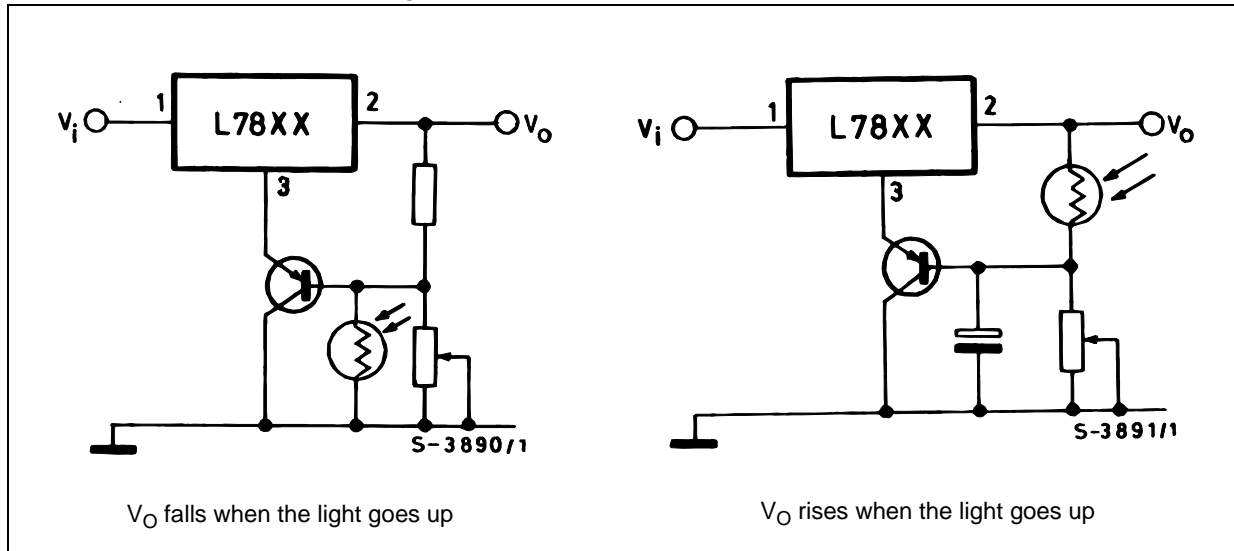

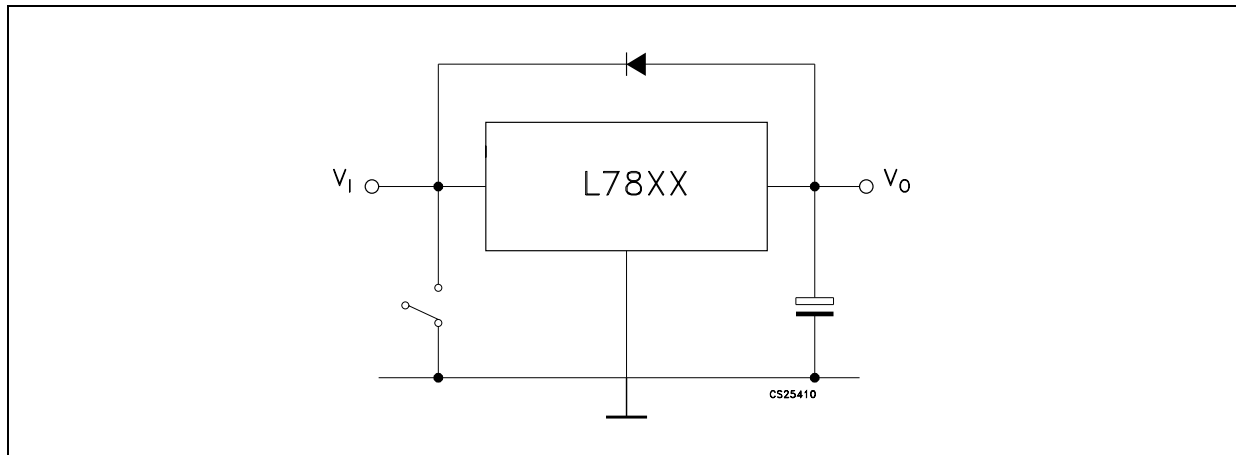
**Figure 36. Protection against input short-circuit with high capacitance loads**

1. Application with high capacitance loads and an output voltage greater than 6 volts need an external diode (see fig. 32) to protect the device against input short circuit. In this case the input voltage falls rapidly while the output voltage decrease slowly. The capacitance discharges by means of the Base-Emitter junction of the series pass transistor in the regulator. If the energy is sufficiently high, the transistor may be destroyed. The external diode by-passes the current from the IC to ground.

## 6 Package mechanical data

In order to meet environmental requirements, ST offers these devices in ECOPACK® packages. These packages have a Lead-free second level interconnect. The category of second Level Interconnect is marked on the package and on the inner box label, in compliance with JEDEC Standard JESD97. The maximum ratings related to soldering conditions are also marked on the inner box label. ECOPACK is an ST trademark. ECOPACK specifications are available at: [www.st.com](http://www.st.com).

<b>TO-3 MECHANICAL DATA</b>						
-----------------------------	--	--	--	--	--	--

DIM.	mm.			inch		
	MIN.	TYP.	MAX.	MIN.	TYP.	MAX.
A		11.85			0.466	
B	0.96	1.05	1.10	0.037	0.041	0.043
C			1.70			0.066
D			8.7			0.342
E			20.0			0.787
G		10.9			0.429	
N		16.9			0.665	
P			26.2			1.031
R	3.88		4.09	0.152		0.161
U			39.5			1.555
V		30.10			1.185	

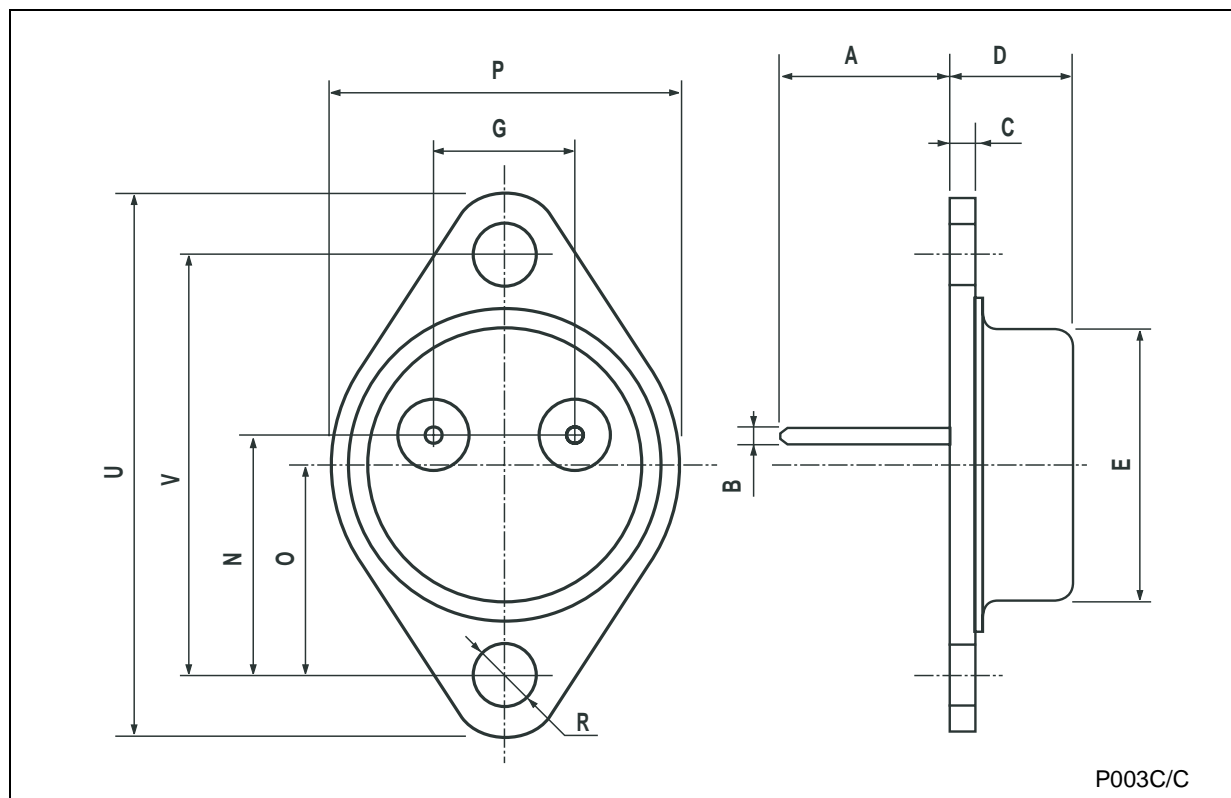

**TO-220 (A TYPE) MECHANICAL DATA**

DIM.	mm.			inch		
	MIN.	TYP	MAX.	MIN.	TYP.	MAX.
A	4.40		4.60	0.173		0.181
b	0.61		0.88	0.024		0.034
b1	1.15		1.70	0.045		0.067
c	0.49		0.70	0.019		0.027
D	15.25		15.75	0.600		0.620
E	10.0		10.40	0.393		0.409
e	2.4		2.7	0.094		0.106
e1	4.95		5.15	0.194		0.203
F	1.23		1.32	0.048		0.051
H1	6.2		6.6	0.244		0.260
J1	2.40		2.72	0.094		0.107
L	13.0		14.0	0.511		0.551
L1	3.5		3.93	0.137		0.154
L20		16.4			0.645	
L30		28.9			1.138	
φP	3.75		3.85	0.147		0.151
Q	2.65		2.95	0.104		0.116

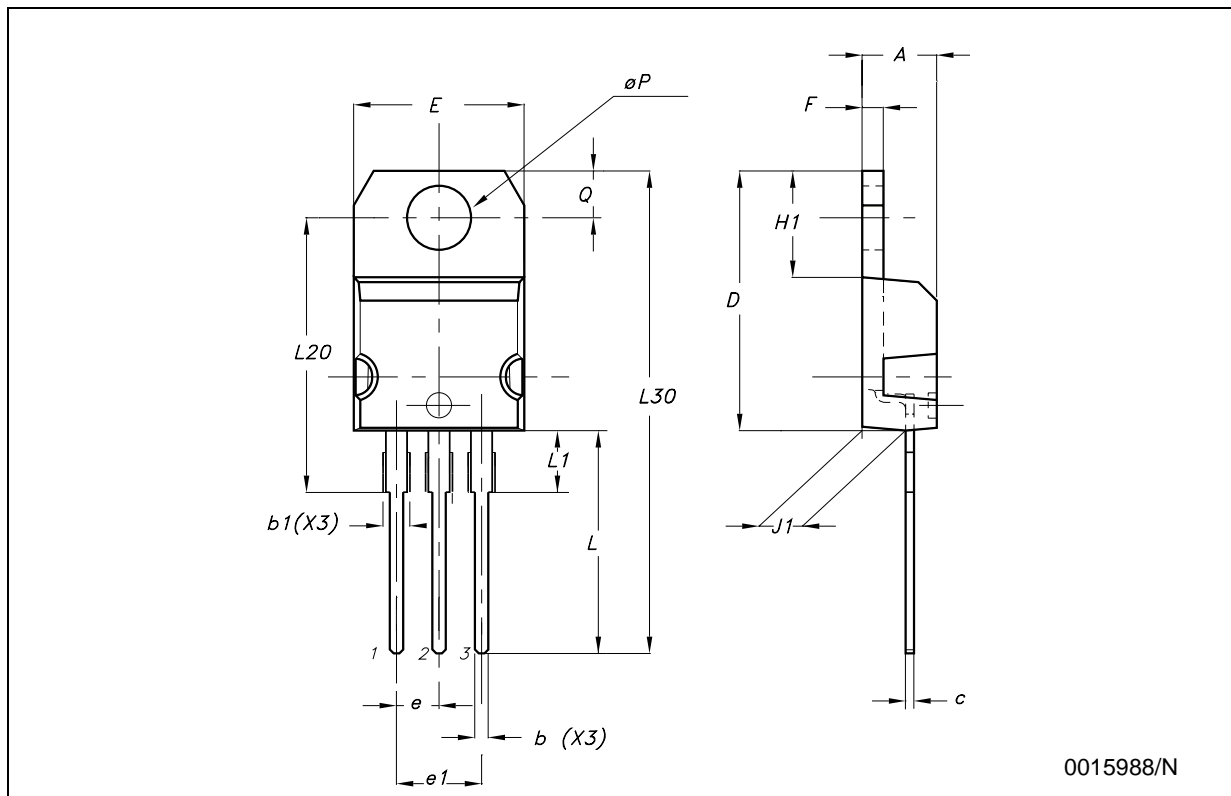

0015988/N

**TO-220 (C TYPE) MECHANICAL DATA**

DIM.	mm.			inch		
	MIN.	TYP	MAX.	MIN.	TYP.	MAX.
A	4.30		4.70	0.169		0.185
b	0.70		0.90	0.028		0.035
b1	1.42		1.62	0.056		0.064
c	0.45		0.60	0.018		0.024
D		15.70			0.618	
E	9.80		10.20	0.386		0.402
e		2.54			0.100	
e1		5.08			0.200	
F	1.25		1.39	0.049		0.055
H1		6.5			0.256	
J1	2.20		2.60	0.087		0.202
L	12.88		13.28	0.507		0.523
L1		3			0.118	
L20	15.70		16.1	0.618		0.634
L30		28.9			1.138	
φP	3.50		3.70	0.138		0.146
Q	2.70		2.90	0.106		0.114

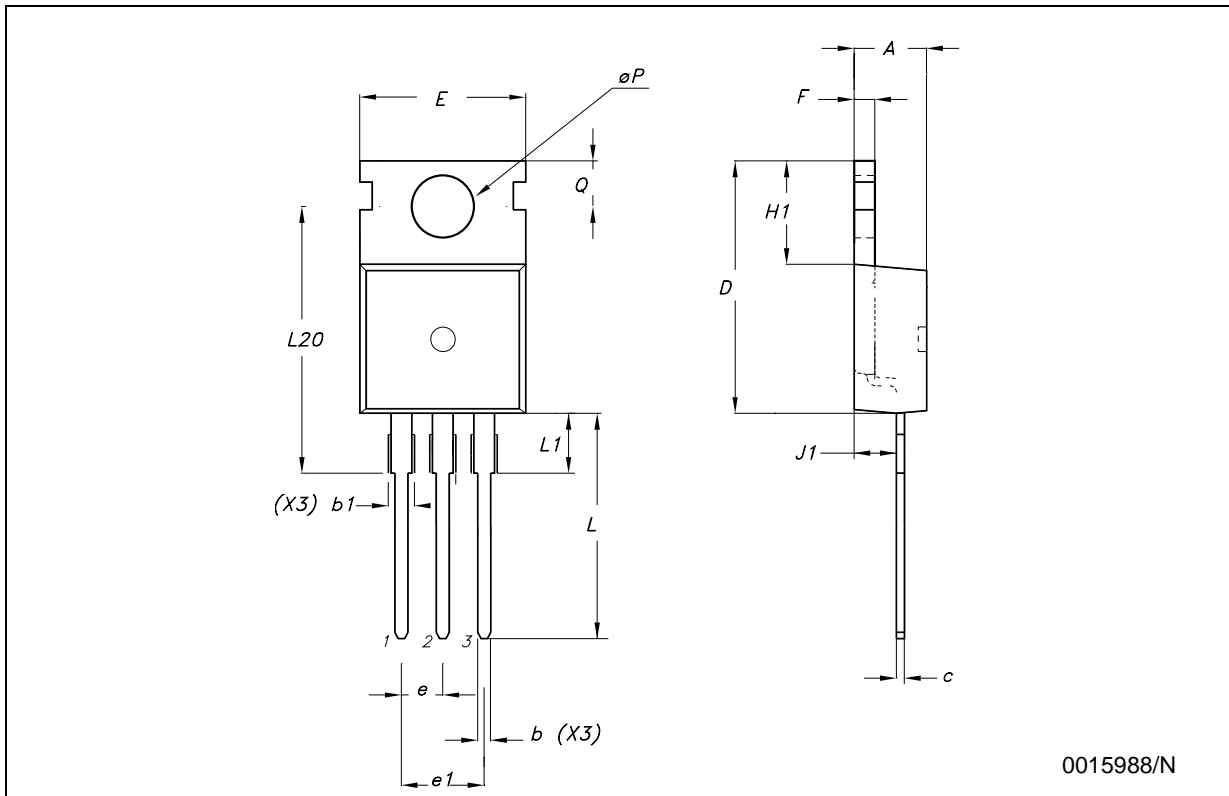

0015988/N

**TO-220 (E TYPE) MECHANICAL DATA**

DIM.	mm.			inch		
	MIN.	TYP	MAX.	MIN.	TYP.	MAX.
A	4.47		4.67	0.176		0.184
b	0.70		0.91	0.028		0.036
b1	1.17		1.37	0.046		0.054
c	0.31		0.53	0.012		0.021
D	14.60		15.70	0.575		0.618
E	9.96		10.36	0.392		0.408
e		2.54			0.100	
e1		5.08			0.200	
F	1.17		1.37	0.046		0.054
H1	6.1		6.8	0.240		0.268
J1	2.52		2.82	0.099		0.111
L	12.70		13.80	0.500		0.543
L1	3.20		3.96	0.126		0.156
L20	15.21		16.77	0.599		0.660
φP	3.73		3.94	0.147		0.155
Q	2.59		2.89	0.102		0.114

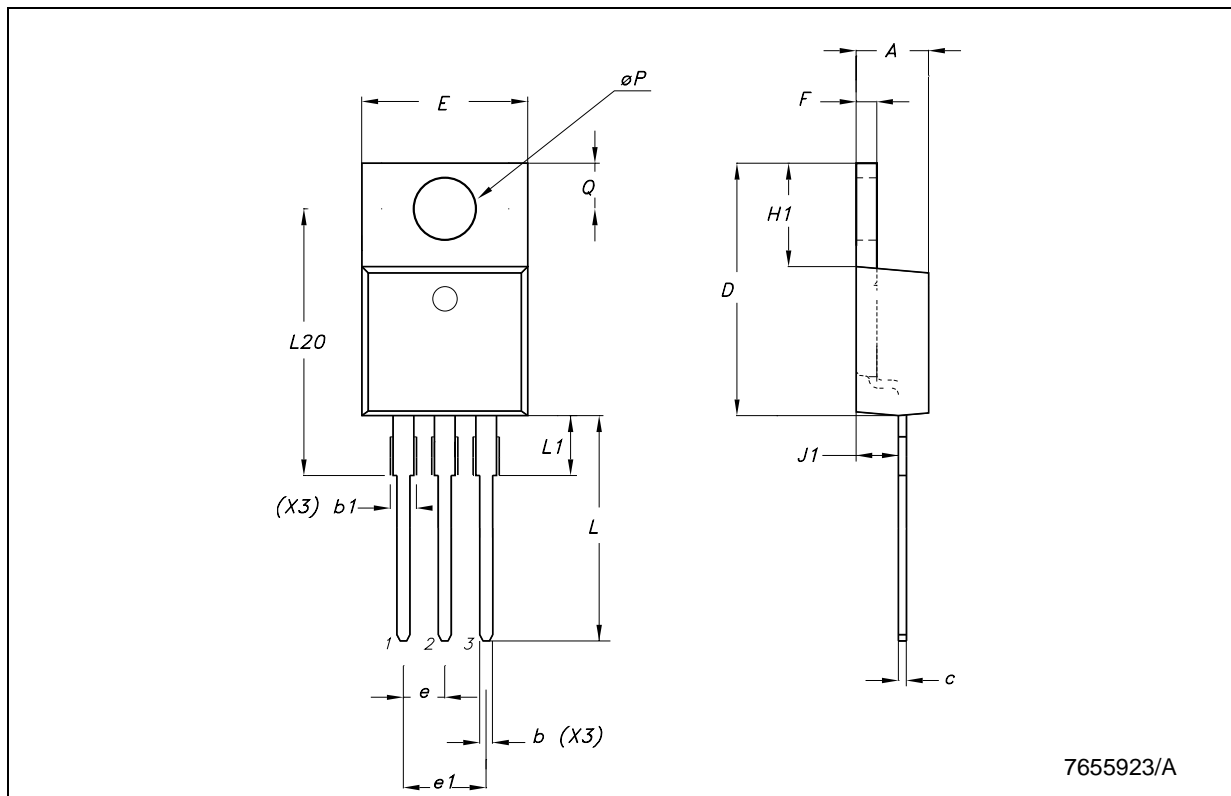

## TO-220FP MECHANICAL DATA

DIM.	mm.			inch		
	MIN.	TYP	MAX.	MIN.	TYP.	MAX.
A	4.40		4.60	0.173		0.181
B	2.5		2.7	0.098		0.106
D	2.5		2.75	0.098		0.108
E	0.45		0.70	0.017		0.027
F	0.75		1	0.030		0.039
F1	1.15		1.50	0.045		0.059
F2	1.15		1.50	0.045		0.059
G	4.95		5.2	0.194		0.204
G1	2.4		2.7	0.094		0.106
H	10.0		10.40	0.393		0.409
L2		16			0.630	
L3	28.6		30.6	1.126		1.204
L4	9.8		10.6	0.385		0.417
L5	2.9		3.6	0.114		0.142
L6	15.9		16.4	0.626		0.645
L7	9		9.3	0.354		0.366
DIA.	3		3.2	0.118		0.126

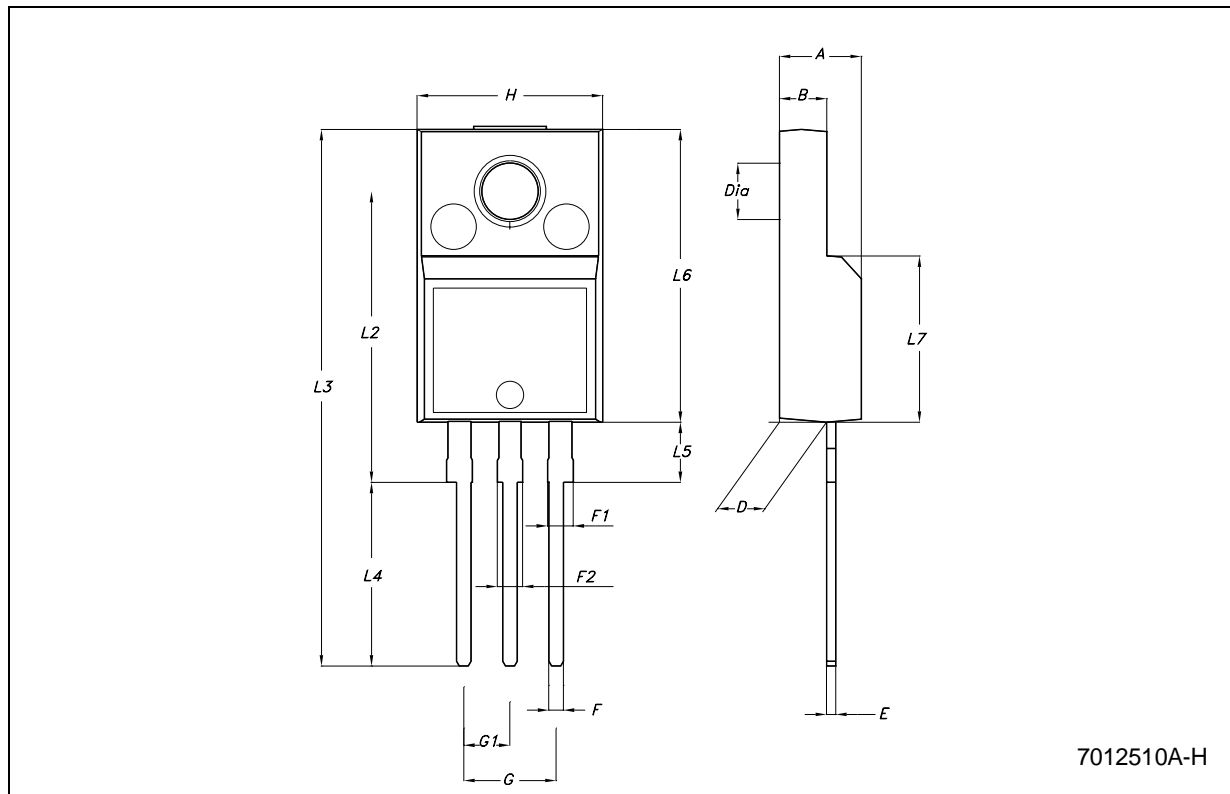

7012510A-H

### D<sup>2</sup>PAK (A TYPE) MECHANICAL DATA

DIM.	mm.			inch		
	MIN.	TYP	MAX.	MIN.	TYP.	MAX.
A	4.4		4.6	0.173		0.181
A1	0.03		0.23	0.001		0.009
b	0.7		0.93	0.027		0.036
b2	1.14		1.7	0.044		0.067
c	0.45		0.6	0.017		0.023
c2	1.23		1.36	0.048		0.053
D	8.95		9.35	0.352		0.368
D1	8			0.315		
E	10		10.4	0.393		0.409
E1	8.5			0.335		
e		2.54			0.100	
e1	4.88		5.28	0.192		0.208
H	15		15.85	0.590		0.624
J1	2.49		2.69	0.098		0.106
L	2.29		2.79	0.090		0.110
L1	1.27		1.4	0.050		0.055
L2	1.3		1.75	0.051		0.069
R		0.4			0.016	
V2	0°		8°	0°		8°

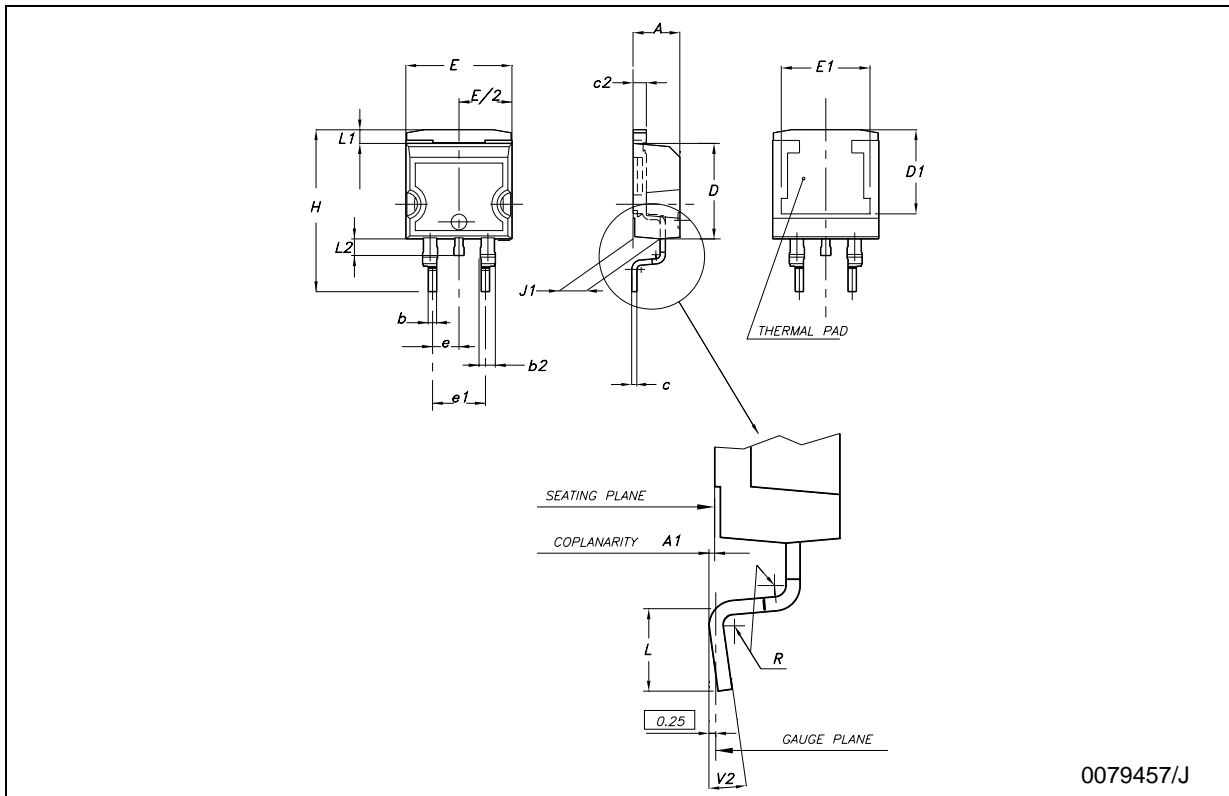

**D<sup>2</sup>PAK (C TYPE) MECHANICAL DATA**

DIM.	mm.			inch		
	MIN.	TYP	MAX.	MIN.	TYP.	MAX.
A	4.3		4.7	0.169		0.185
A1	0		0.20	0.000		0.008
b	0.70		0.90	0.028		0.035
b2	1.17		1.37	0.046		0.054
c	0.45	0.50	0.6	0.018	0.020	0.024
c2	1.25	1.30	1.40	0.049	0.051	0.055
D	9.0	9.2	9.4	0.354	0.362	0.370
D1	7.5			0.295		
E	9.8		10.2	0.386		0.402
E1	7.5			0.295		
e		2.54			0.100	
e1		5.08			0.200	
H	15	15.30	15.60	0.591	0.602	0.614
J1	2.20		2.60	0.087		0.102
L	1.79		2.79	0.070		0.110
L1	1.0		1.4	0.039		0.055
L2	1.2		1.6	0.047		0.063
R		0.3			0.012	
V2	0°		3°	0°		3°

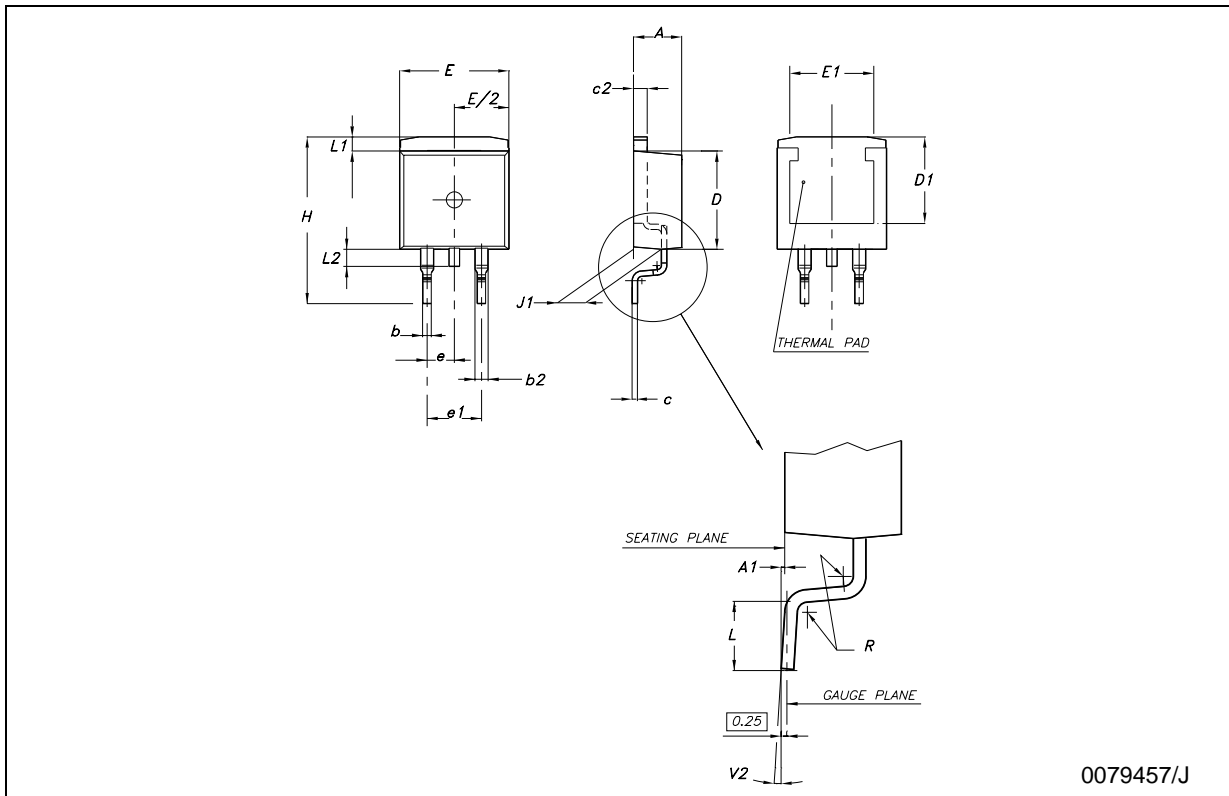

0079457/J

**Tape & Reel D<sup>2</sup>PAK-P<sup>2</sup>PAK-D<sup>2</sup>PAK/A-P<sup>2</sup>PAK/A MECHANICAL DATA**

DIM.	mm.			inch		
	MIN.	TYP	MAX.	MIN.	TYP.	MAX.
A			180			7.086
C	12.8	13.0	13.2	0.504	0.512	0.519
D	20.2			0.795		
N	60			2.362		
T			14.4			0.567
Ao	10.50	10.6	10.70	0.413	0.417	0.421
Bo	15.70	15.80	15.90	0.618	0.622	0.626
Ko	4.80	4.90	5.00	0.189	0.193	0.197
Po	3.9	4.0	4.1	0.153	0.157	0.161
P	11.9	12.0	12.1	0.468	0.472	0.476

