

Single 8-channel analog multiplexer/demultiplexer

Datasheet - production data

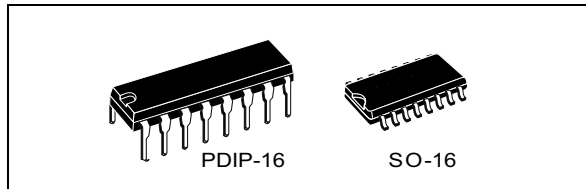

Features

- Low “ON” resistance: 125 Ω (typ.)
- Over 15 V p.p signal-input range for $V_{DD} - V_{EE} = 15$ V
- High “OFF” resistance, channel leakage: ± 100 pA (typ.) at $V_{DD} - V_{EE} = 18$ V
- Binary address decoding on chip
- High degree of linearity: < 0.5 % distortion typ. at $f_{IS} = 1$ KHz, $V_{IS} = 5$ V_{pp}, $V_{DD} - V_{SS} \geq 10$ V, $R_L = 10$ k Ω
- Very low quiescent power dissipation under all digital control input and supply conditions: 0.2 μ W (typ.) $V_{DD} - V_{SS} = V_{DD} - V_{EE} = 10$ V
- Matched switch characteristics: $R_{ON} = 5$ Ω (typ.) for $V_{DD} - V_{EE} = 15$ V
- Wide range of digital and analog signal levels: digital 3 to 20, analog to 20 V p.p.
- Quiescent current specified up to 20 V
- 5 V, 10 V and 15 V parametric ratings
- ESD performance
 - HBM: 2 kV
 - MM: 200 V
 - CDM: 750 V

- Input leakage current $I_I = 100$ nA (max.) at $V_{DD} = 18$ V, $T_A = 25$ °C
- 100 % tested for quiescent current

Applications

- Automotive
- Industrial
- Computer
- Consumer

Description

The HCF4051 device is a monolithic integrated circuit fabricated in MOS (metal oxide semiconductor) technology available in SO-16 and PDIP-16 packages.

The HCF4051 analog multiplexer/demultiplexer is a digitally controlled analog switch having low ON impedance and very low OFF leakage current. This multiplexer circuit dissipates extremely low quiescent power over the full $V_{DD} - V_{SS}$ and $V_{DD} - V_{EE}$ supply voltage range, independent of the logic state of the control signals.

This device is a single 8-channel multiplexer having three binary control inputs, A, B, and C, and an inhibit input. The three binary signals select 1 of 8 channels to be turned on, and connect one of the 8 inputs to the output. When a logic “1” is present at the inhibit input terminal all channels are off.

Table 1. Device summary

Order code	Temperature range	Package	Packaging	Marking
HCF4051M013TR	-55/+125 °C	SO-16	Tape and reel	HCF4051
HCF4051YM013TR ⁽¹⁾	-40/+125 °C	SO16 (automotive version)		HCF4051Y
HCF4051BEY	-55/+125 °C	PDIP-16	Tube	HCF4051BE

1. Qualification and characterization according to AEC Q100 and Q003 or equivalent, advanced screening according to AEC Q001 and Q002 or equivalent.

Contents

1	Pin information	3
2	Functional description	4
3	Electrical characteristics	6
4	Package information	11
	4.1 PDIP-16 (0.25) package information	12
	4.2 SO-16 package information	13
5	Ordering information	14
6	Revision history	14

1 Pin information

Figure 1. Pin connections (top view)

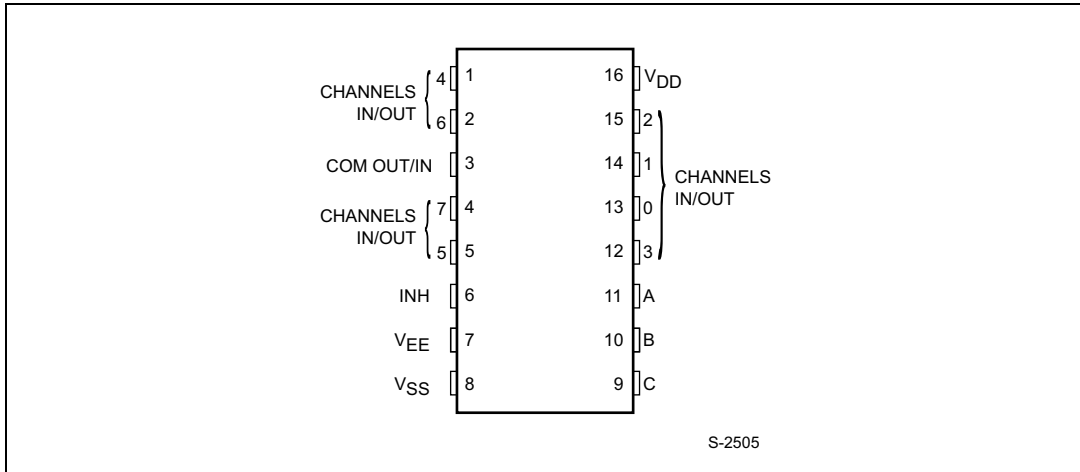

Table 2. Pin description

Pin no.	Symbol	Name and function
11, 10, 9	A, B, C	Binary control inputs
6	INH	Inhibit inputs
13, 14, 15, 12, 1, 5, 2, 4	0 to 7 channel IN/OUT	Independent inputs/outputs
3	COM OUT/IN	Common output/input
7	V _{EE}	Supply voltage
8	V _{SS}	Negative supply voltage
16	V _{DD}	Positive supply voltage

2 Functional description

Table 3. Truth table

Input states				"ON" channel (S)
Inhibit	C	B	A	
0	0	0	0	0
0	0	0	1	1
0	0	1	0	2
0	0	1	1	3
0	1	0	0	4
0	1	0	1	5
0	1	1	0	6
0	1	1	1	7
1	X	X	X	None

Figure 2. Functional diagram

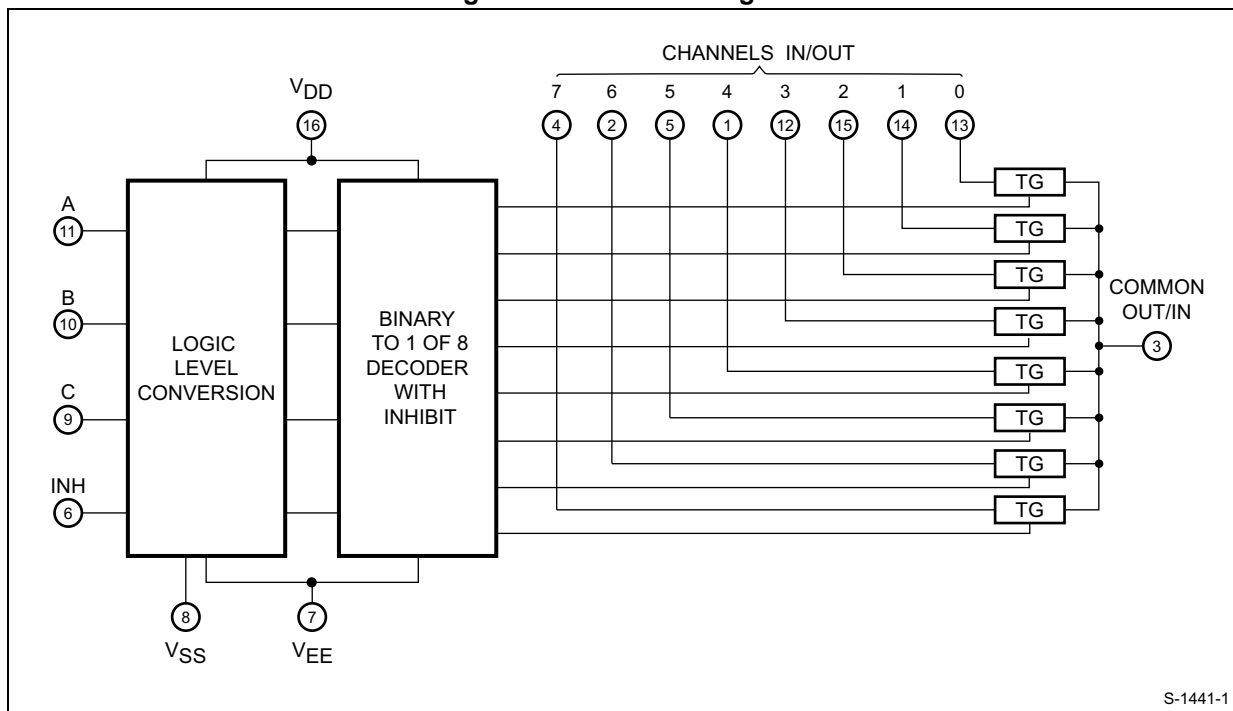
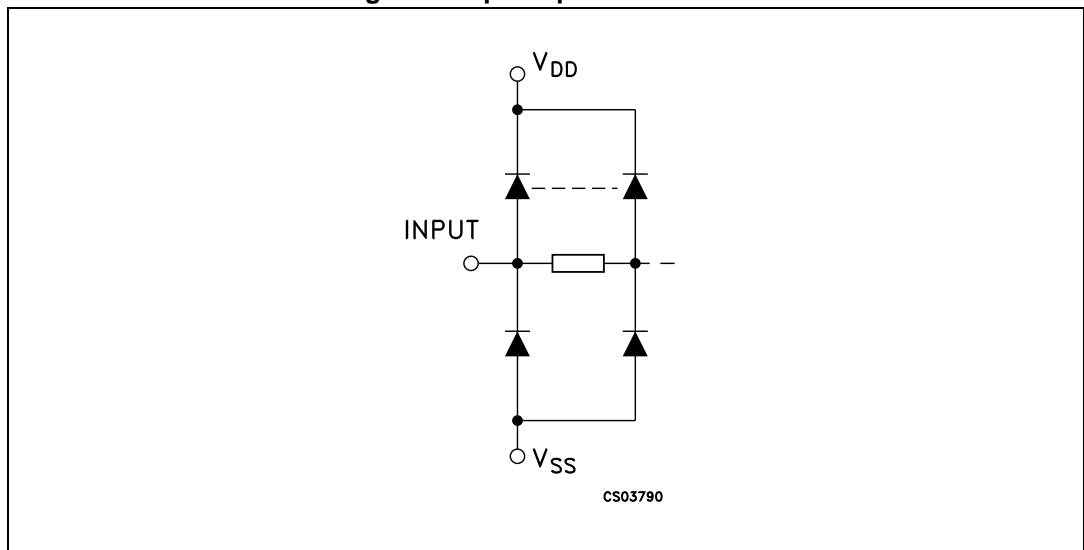

Figure 3. Input equivalent circuit



3 Electrical characteristics

Absolute maximum ratings are those values beyond which damage to the device may occur. Functional operation under these conditions is not implied. All voltage values are referred to V_{SS} pin voltage.

Table 4. Absolute maximum ratings

Symbol	Parameter	Value	Unit
V_{DD}	Supply voltage	-0.5 to +22	V
V_I	DC input voltage	-0.5 to $V_{DD} + 0.5$	
I_I	DC input current	± 10	mA
P_D	Power dissipation per package	500 ⁽¹⁾	mW
	Power dissipation per output transistor	100	
T_{op}	Operating temperature	-55 to +125	°C
T_{stg}	Storage temperature	-65 to +150	

1. 500 mW at 65 °C; derate to 300 mW by 10 mW/°C from 65 °C to 85 °C.

Table 5. Recommended operating conditions

Symbol	Parameter	Value	Unit
V_{DD}	Supply voltage	3 to 20	V
V_I	Input voltage	0 to V_{DD}	
T_{op}	Operating temperature	-55 to 125	°C

Table 6. DC specifications

Symbol	Parameter	Test condition				Value					Unit
		V_{IS} (V)	V_{EE} (V)	V_{SS} (V)	V_{DD} (V)	$T_A = 25\text{ }^\circ\text{C}$			$-55\text{ to }125\text{ }^\circ\text{C}$		
						Min.	Typ.	Max.	Min.	Max.	
I_L	Quiescent device current (all switches ON or all switches OFF)				5		0.04	5		150	μA
					10		0.04	10		300	
					15		0.04	20		600	
					20		0.08	100		3000	
Switch											
R_{ON}	Resistance	$0 \leq V_I \leq V_{DD}$	0	0	5		470	1050		1200	Ω
					10		180	400		520	
					15		125	280		360	
D_{ON}	Resistance ΔR_{ON} (between any 2 of 4 switches)	$0 \leq V_I \leq V_{DD}$	0	0	5		10				Ω
					10		10				
					15		5				
OFF ⁽¹⁾	Channel leakage current (all channels OFF) (COMMON O/I)		0	0	18		± 0.1	100		1000	nA
OFF ⁽¹⁾	Channel leakage current (any channel OFF)		0	0	18		± 0.1	100		1000	
C_I	Input capacitance						5				pF
C_O	Output capacitance		-5	-5	5		30				
C_{IO}	Feedthrough						0.2				
Control (address or inhibit)											
V_{IL}	Input low voltage	$= V_{DD}$ through 1 K Ω		$V_{EE} = V_{SS}$ $R_L = 1\text{K}\Omega$ to V_{SS} $I_{IS} < 2\mu\text{A}$ (on all OFF channels)	5			1.5		1.5	V
					10			3		3	
					15			4		4	
V_{IH}	Input high voltage				5	3.5			3.5		V
					10	7			7		
					15	11			11		
I_{IH}, I_{IL}	Input leakage current		$V_I = 0/18\text{ V}$		18		$\pm 10^{-3}$	± 0.1		± 1	μA
C_I	Input capacitance						5	7.5			pF

1. Determined by minimum feasible leakage measurement for automating testing.

Table 7. Dynamic electrical characteristics
 (T_{amb} = 25 °C, C_L = 50 pF, all input square wave rise and fall time = 20 ns)⁽¹⁾

Parameter	Test condition							Value			Unit
	V _{EE} (V)	R _L (KΩ)	f _i (KHz)	V _I (V)	V _{SS} (V)	V _{DD} (V)	Min.	Typ.	Max.		
Propagation delay time (signal input to output)		200		V _{DD} 		5			30	60	ns
						10			15	30	
						15			11	20	
Frequency response channel "ON" (sine wave input) at 20 log V _O /V _I = -3 dB	=V _{SS}	1		5 ⁽²⁾		10	V _O at common OUT/IN		20		MHz
							V _O at any channel		60		
Feedthrough (all channels OFF) at 20 log V _O /V _I = -40 dB	=V _{SS}	1		5 ⁽²⁾		10	V _O at common OUT/IN		12		MHz
							V _O at any channel		8		
Frequency signal crosstalk at 20 log V _O /V _I = -40 dB	=V _{SS}	1		5 ⁽²⁾		10	Between any 2 channels		3		
Sine wave distortion f _{IS} = 1 KHz sine wave	=V _{SS}	10	1	2 ⁽²⁾		5			0.3		%
				3 ⁽²⁾		10			0.2		
				5 ⁽²⁾		15			0.12		
Control (address or inhibit)											
Propagation delay: address to signal OUT (channels ON or OFF)	0					0	5		360	720	ns
	0					0	10		160	320	
	0					0	15		120	240	
	-5					0	5		225	450	
Propagation delay: inhibit to signal OUT (channel turning ON)	0	1				0	5		360	720	ns
	0					0	10		160	320	
	0					0	15		120	240	
	-10					0	5		200	400	
Propagation delay: inhibit to signal OUT (channel turning OFF)	0	10					5		200	450	ns
	0						10		90	210	
	0						15		70	160	
	-10						5		130	300	
Address or inhibit to signal crosstalk	0	10 ⁽¹⁾			0	10	V _C = V _{DD} - V _{SS} (square wave)		65		mV peak

1. Both ends of channel.
 2. Peak-to-peak voltage symmetrical about (V_{DD} - V_{EE}) / 2.

Figure 4. Typical bias voltages

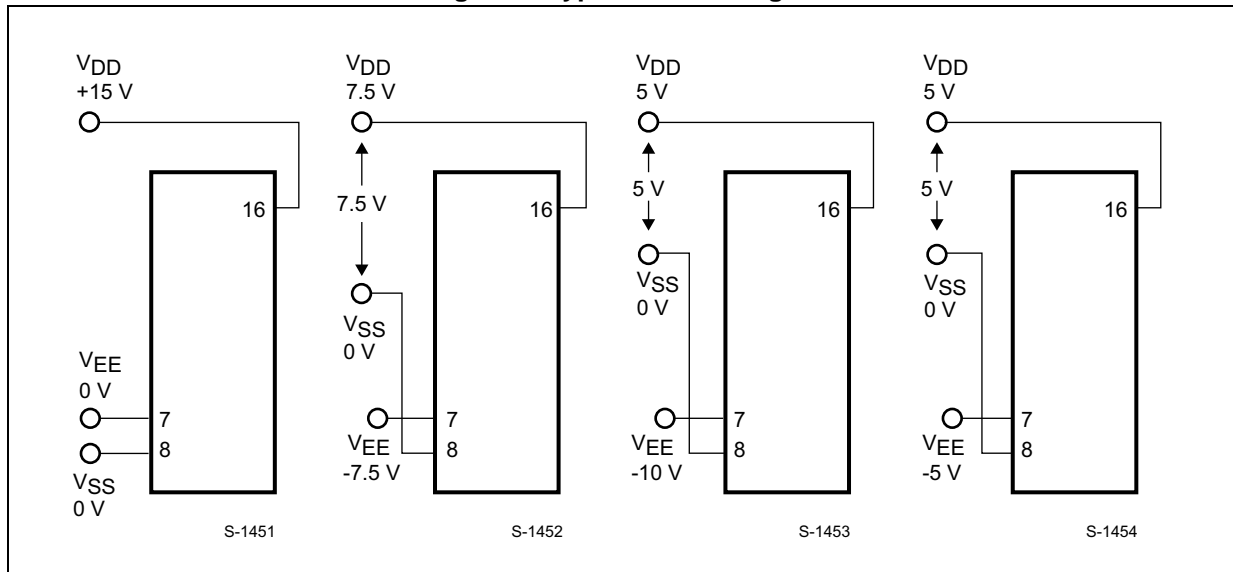

- The ADDRESS (digital-control inputs) and INHIBIT logic levels are : "0" = V_{SS} and "1" = V_{DD} . The analog signal (through the TG) may swing from V_{EE} to V_{DD} .

Special considerations

Control of analog signals up to 20 V peak-to-peak can be achieved by digital signal amplitudes of 4.5 to 20 V (if $V_{DD} - V_{SS} = 3$ V, a $V_{DD} - V_{EE}$ of up to 13 V can be controlled; for $V_{DD} - V_{EE}$ level differences above 13 V, a $V_{DD} - V_{SS}$ of at least 4.5 V is required).

For example, if $V_{DD} = +5$, $V_{SS} = 0$, and $V_{EE} = -13.5$, analog signals from -13.5 V to 4.5 V can be controlled by digital inputs of 0 to 4.5 V. In certain applications, the external load resistor current may include both V_{DD} and signal-line components. To avoid drawing V_{DD} current when switch current flows into the transmission gate inputs, the voltage drop across the bidirectional switch must not exceed 0.8 V (calculated from R_{ON} values shown in [Table 6: DC specifications](#)). No V_{DD} current flows through R_L if the switch current flows into lead 3.

Figure 5. Test circuit

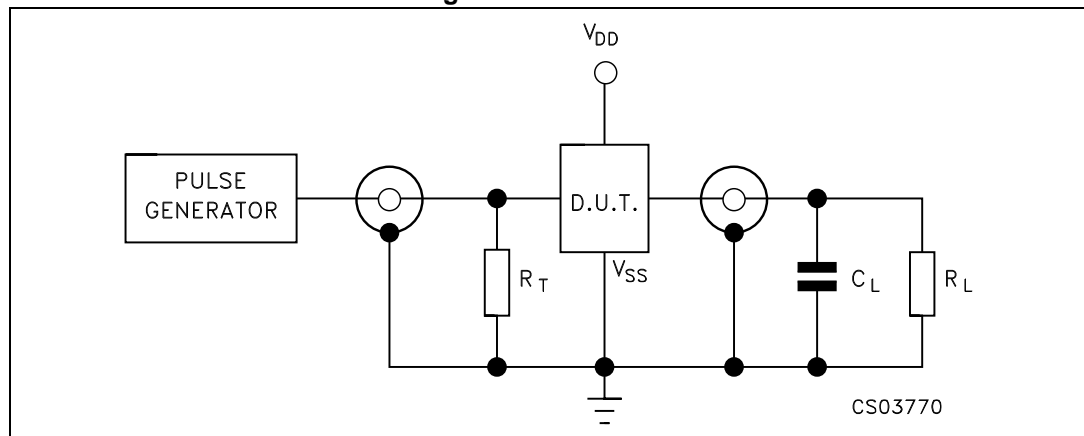

- $C_L = 50$ pF or equivalent (includes jig and probe capacitance)
 $R_L = 200$ K Ω
 $R_T = Z_{OUT}$ of pulse generator (typically 50 Ω).

Figure 6. Waveform 1: channel turned ON
($R_L = 1\text{ K}\Omega$, $f = 1\text{ MHz}$; 50 % duty cycle)

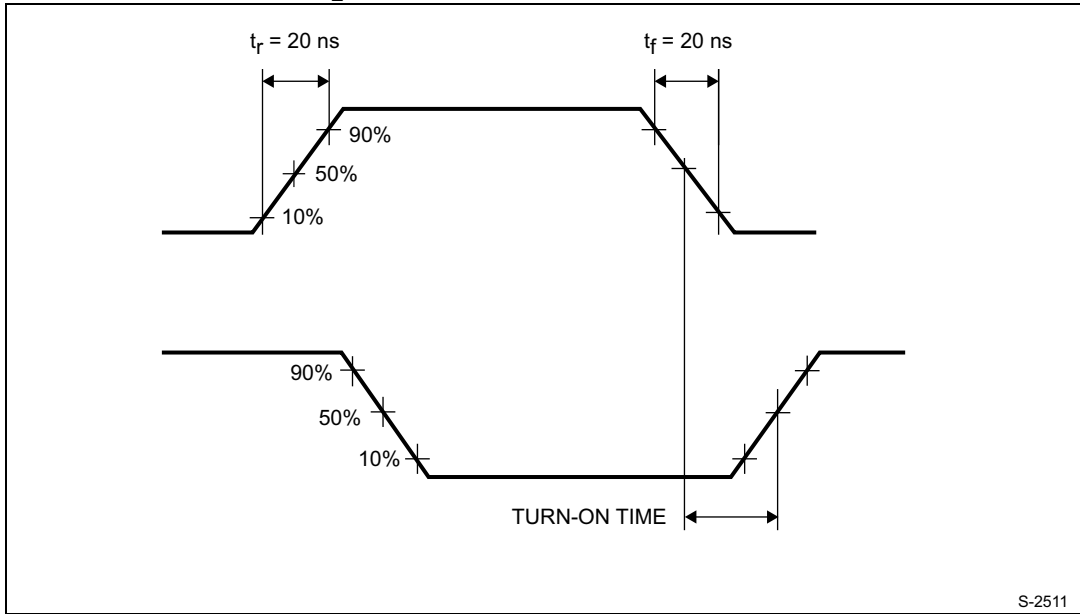
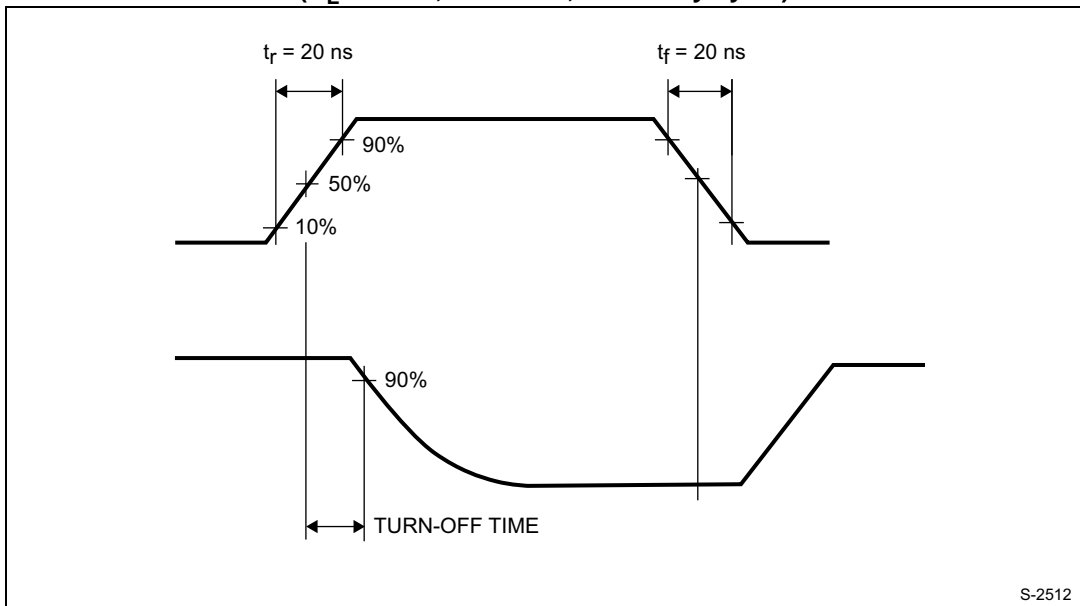

Figure 7. Waveform 2: channel turned OFF
($R_L = 1\text{ KW}$, $f = 1\text{ MHz}$; 50 % duty cycle)



4 Package information

In order to meet environmental requirements, ST offers these devices in different grades of ECOPACK[®] packages, depending on their level of environmental compliance. ECOPACK specifications, grade definitions and product status are available at: www.st.com. ECOPACK is an ST trademark.

4.1 PDIP-16 (0.25) package information

Figure 8. PDIP-16 (0.25) package mechanical drawing

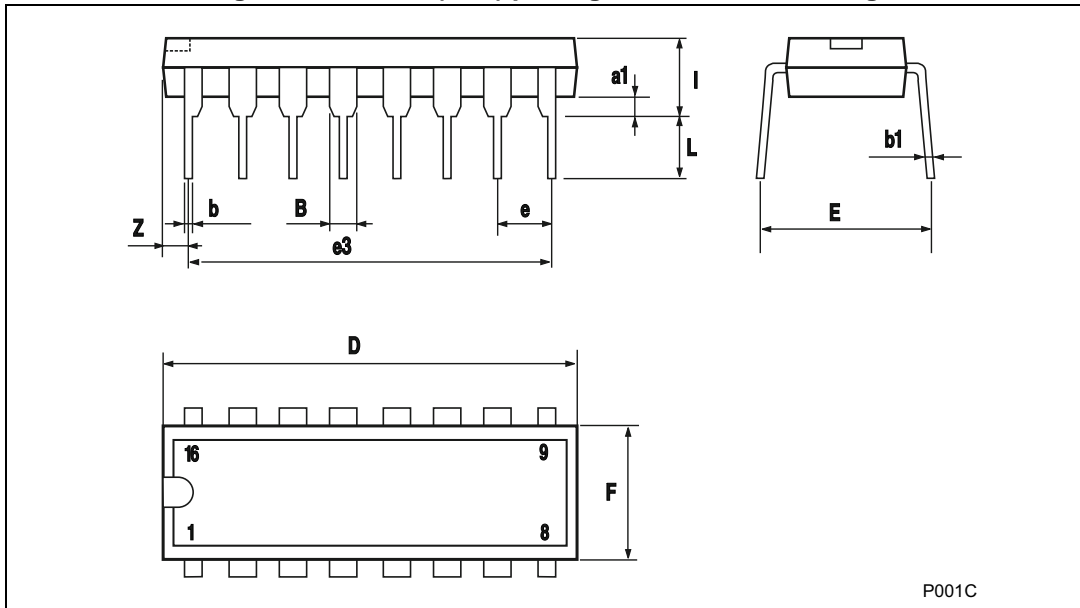

P001C

Table 8. PDIP-16 (0.25) package mechanical data

Symbol	Dimensions					
	mm			inch		
	Min.	Typ.	Max.	Min.	Typ.	Max.
a1	0.51			0.020		
B	0.77		1.65	0.030		0.065
b		0.5			0.020	
b1		0.25			0.010	
D			20			0.787
E		8.5			0.335	
e		2.54			0.100	
e3		17.78			0.700	
F			7.1			0.280
I			5.1			0.201
L		3.3			0.130	
Z			1.27			0.050

4.2 SO-16 package information

Figure 9. SO-16 package mechanical drawing

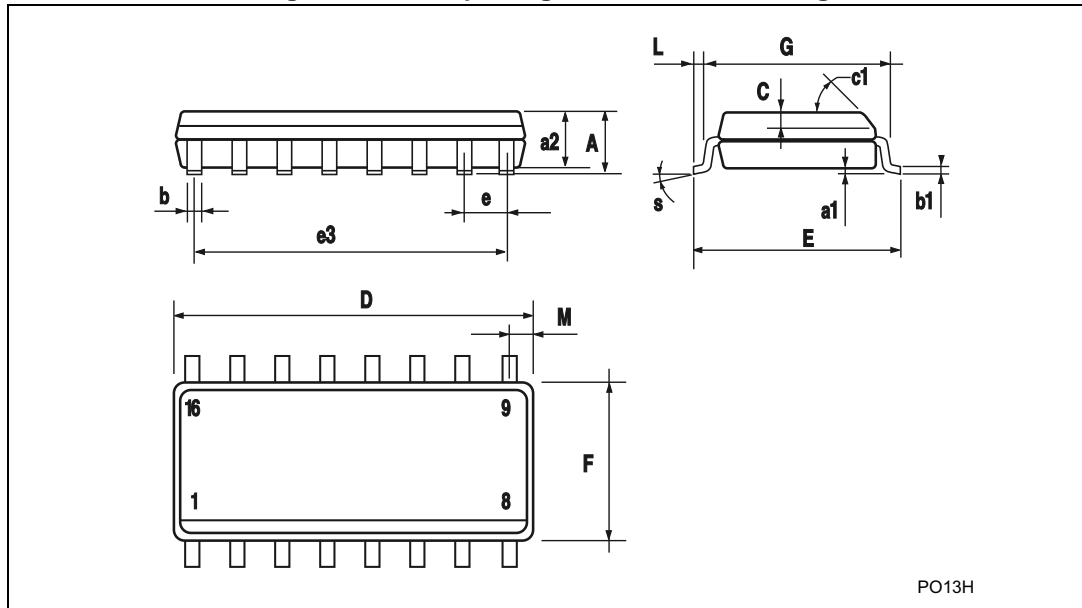

Table 9. SO-16 package mechanical data

Symbol	Dimensions					
	mm			inch		
	Min.	Typ.	Max.	Min.	Typ.	Max.
A			1.75			0.068
a1	0.1		0.2	0.003		0.007
a2			1.65			0.064
b	0.35		0.46	0.013		0.018
b1	0.19		0.25	0.007		0.010
C		0.5			0.019	
c1	45° (typ.)					
D	9.8		10	0.385		0.393
E	5.8		6.2	0.228		0.244
e		1.27			0.050	
e3		8.89			0.350	
F	3.8		4.0	0.149		0.157
G	4.6		5.3	0.181		0.208
L	0.5		1.27	0.019		0.050
M			0.62			0.024
S	8° (max.)					

5 Ordering information

Table 10. Order codes

Order code	Temperature range	Package	Packaging	Marking
HCF4051M013TR	-55/+125 °C	SO-16	Tape and reel	HCF4051
HCF4051YM013TR ⁽¹⁾	-40/+125 °C	SO16 (automotive version)		HCF4051Y
HCF4051BEY	-55/+125 °C	PDIP-16	Tube	HCF4051BE

1. Qualification and characterization according to AEC Q100 and Q003 or equivalent, advanced screening according to AEC Q001 and Q002 or equivalent.

6 Revision history

Table 11. Document revision history

Date	Revision	Changes
26-Oct-2012	2	Updated Features (added ESD values), added Applications . Updated Table 1 (reformatted table, added order codes, temperature range, marking, updated package and packaging). Updated Description (unified part numbers, moved to page 2). Updated Section 2 to Section 4 (added titles and numbering). Updated Table 6 (removed -40/+85° temperature range). Reformatted Section 4 (added ECOPACK text, Figure 8 , Figure 9 , Table 8 , and Table 9). Minor corrections throughout document.
30-Apr-2013	3	Updated Features (ESD values) Added Section 5: Ordering information