



Is Now Part of



**ON Semiconductor®**

To learn more about ON Semiconductor, please visit our website at  
[www.onsemi.com](http://www.onsemi.com)

ON Semiconductor and the ON Semiconductor logo are trademarks of Semiconductor Components Industries, LLC dba ON Semiconductor or its subsidiaries in the United States and/or other countries. ON Semiconductor owns the rights to a number of patents, trademarks, copyrights, trade secrets, and other intellectual property. A listing of ON Semiconductor's product/patent coverage may be accessed at [www.onsemi.com/site/pdf/Patent-Marking.pdf](http://www.onsemi.com/site/pdf/Patent-Marking.pdf). ON Semiconductor reserves the right to make changes without further notice to any products herein. ON Semiconductor makes no warranty, representation or guarantee regarding the suitability of its products for any particular purpose, nor does ON Semiconductor assume any liability arising out of the application or use of any product or circuit, and specifically disclaims any and all liability, including without limitation special, consequential or incidental damages. Buyer is responsible for its products and applications using ON Semiconductor products, including compliance with all laws, regulations and safety requirements or standards, regardless of any support or applications information provided by ON Semiconductor. "Typical" parameters which may be provided in ON Semiconductor data sheets and/or specifications can and do vary in different applications and actual performance may vary over time. All operating parameters, including "Typicals" must be validated for each customer application by customer's technical experts. ON Semiconductor does not convey any license under its patent rights nor the rights of others. ON Semiconductor products are not designed, intended, or authorized for use as a critical component in life support systems or any FDA Class 3 medical devices or medical devices with a same or similar classification in a foreign jurisdiction or any devices intended for implantation in the human body. Should Buyer purchase or use ON Semiconductor products for any such unintended or unauthorized application, Buyer shall indemnify and hold ON Semiconductor and its officers, employees, subsidiaries, affiliates, and distributors harmless against all claims, costs, damages, and expenses, and reasonable attorney fees arising out of, directly or indirectly, any claim of personal injury or death associated with such unintended or unauthorized use, even if such claim alleges that ON Semiconductor was negligent regarding the design or manufacture of the part. ON Semiconductor is an Equal Opportunity/Affirmative Action Employer. This literature is subject to all applicable copyright laws and is not for resale in any manner.

## FSCQ-Series: FSCQ0565RT / FSCQ0765RT / FSCQ0965RT / FSCQ1265RT / FSCQ1565RT Green Mode Fairchild Power Switch (FPS™)

### Features

- Optimized for Quasi-Resonant Converter (QRC)
- Advanced Burst-Mode Operation for under 1 W Standby Power Consumption
- Pulse-by-Pulse Current Limit
- Overload Protection (OLP) – Auto Restart
- Over-Voltage Protection (OVP) – Auto Restart
- Abnormal Over-Current Protection (AOCP) – Latch
- Internal Thermal Shutdown (TSD) – Latch
- Under-Voltage Lockout (UVLO) with Hysteresis
- Low Startup Current (Typical: 25  $\mu$ A)
- Internal High Voltage SenseFET
- Built-in Soft-Start (20 ms)
- Extended Quasi-Resonant Switching

### Applications

- CTV
- Audio Amplifier

### Related Resources

- [AN-4146 — Design Guidelines for Quasi-Resonant Converters Using FSCQ-Series Fairchild Power Switch](#)
- [AN-4140 — Transformer Design Consideration for Offline Flyback Converters Using Fairchild Power Switch](#)

### Description

A Quasi-Resonant Converter (QRC) typically shows lower EMI and higher power conversion efficiency compared to a conventional hard-switched converter with a fixed switching frequency. Therefore, a QRC is well suited for noise-sensitive applications, such as color TV and audio. Each product in the FSCQ series contains an integrated Pulse Width Modulation (PWM) controller and a SenseFET. This series is specifically designed for quasi-resonant off-line Switch Mode Power Supplies (SMPS) with minimal external components. The PWM controller includes an integrated fixed frequency oscillator, under-voltage lockout, leading-edge blanking (LEB), optimized gate driver, internal soft-start, temperature-compensated precise current sources for loop compensation, and self-protection circuitry. Compared with a discrete MOSFET and PWM controller solution, the FSCQ series can reduce total cost, component count, size, and weight; while increasing efficiency, productivity, and system reliability. These devices provide a basic platform for cost-effective designs of quasi-resonant switching flyback converters.

### Ordering Information

Part Number	Package	Marking Code	BV <sub>DSS</sub> (V)	R <sub>DS(on)</sub> Max. ( $\Omega$ )
FSCQ0565RTYDTU	TO-220F-5L (Forming)	CQ0565RT	650	2.2
FSCQ0765RTYDTU	TO-220F-5L (Forming)	CQ0765RT	650	1.6
FSCQ0965RTYDTU	TO-220F-5L (Forming)	CQ0965RT	650	1.2
FSCQ1265RTYDTU	TO-220F-5L (Forming)	CQ1265RT	650	0.9
FSCQ1565RTYDTU	TO-220F-5L (Forming)	CQ1565RT	650	0.7

**Typical Circuit**

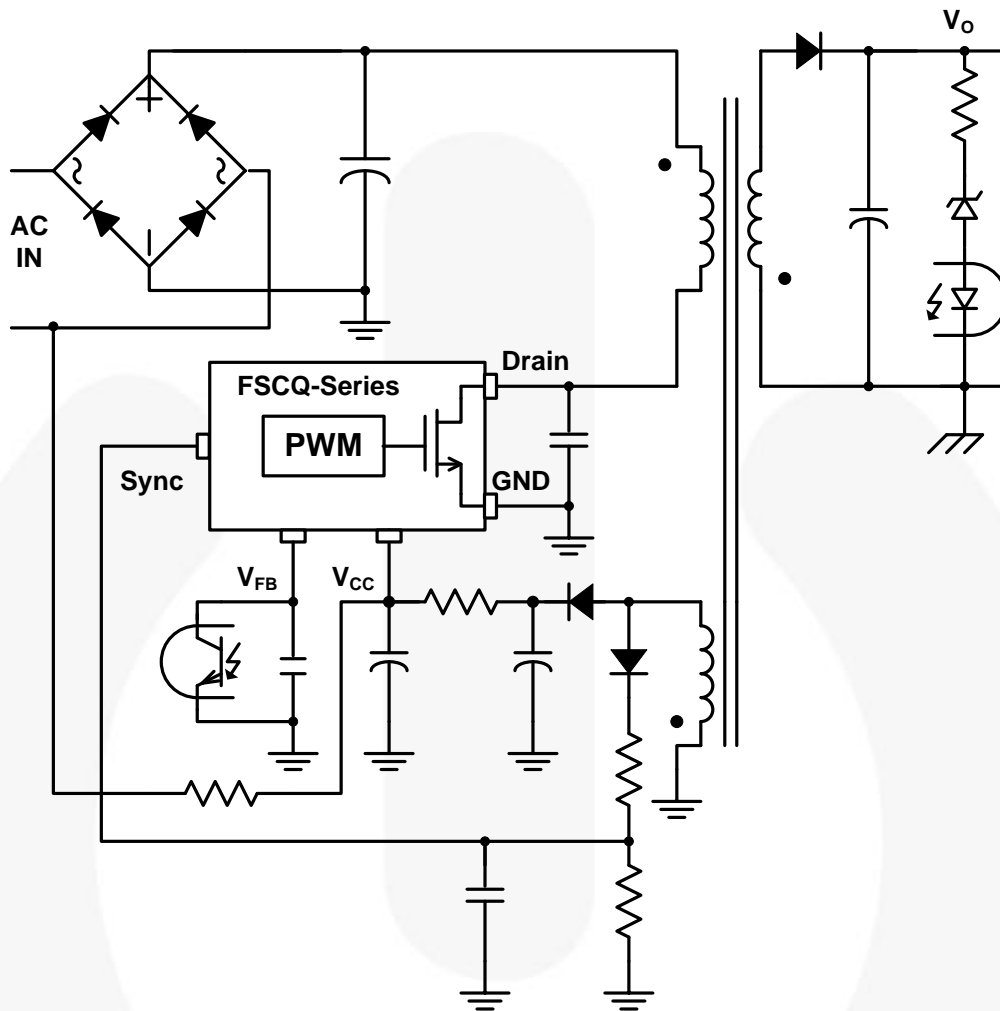

**Figure 1. Typical Flyback Application**

**Table 1. Maximum Output Power<sup>(1)</sup>**

Product	230 V <sub>AC</sub> ±15% <sup>(2)</sup>	85–265 V <sub>AC</sub>
	Open Frame <sup>(3)</sup>	Open Frame <sup>(3)</sup>
FSCQ0565RT	70 W	60 W
FSCQ0765RT	100 W	85 W
FSCQ0965RT	130 W	110 W
FSCQ1265RT	170 W	140 W
FSCQ1565RT	210 W	170 W

**Notes:**

1. The junction temperature can limit the maximum output power.
2. 230 V<sub>AC</sub> or 100/115 V<sub>AC</sub> with doubler.
3. Maximum practical continuous power in an open frame design at 50°C ambient.

Internal Block Diagram

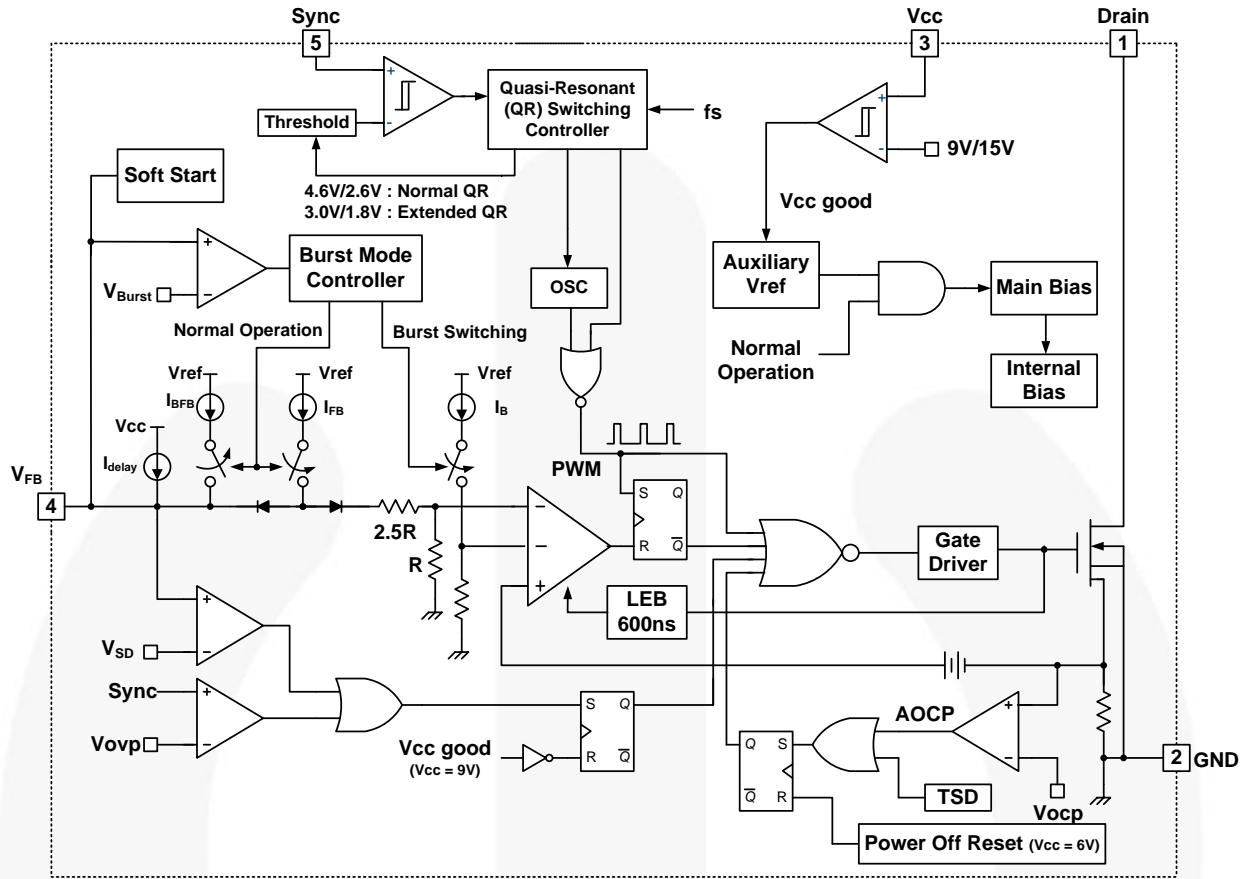

Figure 2. Functional Block Diagram

## Pin Configuration

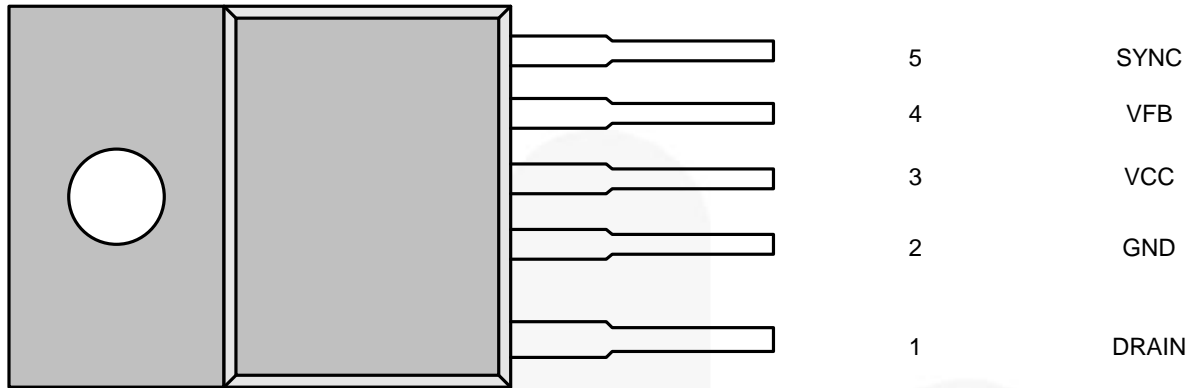

Figure 3. Pin Assignments (Top View)

## Pin Descriptions

Pin	Name	Description
1	DRAIN	This pin is the high-voltage power SenseFET drain connection.
2	GND	This pin is the control ground and the SenseFET source.
3	VCC	This pin is the positive supply input. This pin provides internal operating current for both startup and steady-state operation.
4	VFB	This pin is internally connected to the inverting input of the PWM comparator. The collector of an opto-coupler is typically tied to this pin. For stable operation, a capacitor should be placed between this pin and GND. If the voltage of this pin reaches 7.5 V, the overload protection triggers, which results in the FPS™ shutting down.
5	SYNC	This pin is internally connected to the sync detect comparator for quasi-resonant switching. In normal quasi-resonant operation, the threshold of the sync comparator is 4.6 V / 2.6 V. Whereas, the sync threshold is changed to 3.0 V / 1.8 V in an extended quasi-resonant operation.

## Absolute Maximum Ratings

Stresses exceeding the absolute maximum ratings may damage the device. The device may not function or be operable above the recommended operating conditions and stressing the parts to these levels is not recommended. In addition, extended exposure to stresses above the recommended operating conditions may affect device reliability. The absolute maximum ratings are stress ratings only.  $T_A = 25^\circ\text{C}$ , unless otherwise specified.

Symbol	Parameter	Value	Unit	
$V_{DS}$	Drain Pin Voltage	650	V	
$V_{CC}$	Supply Voltage	20	V	
$V_{sync}$	Analog Input Voltage Range	-0.3 to 13	V	
$V_{FB}$		-0.3 to $V_{CC}$		
$I_{DM}$	Drain Current Pulsed <sup>(4)</sup>	FSCQ0565RT	11.2	A
		FSCQ0765RT	15.2	
		FSCQ0965RT	16.4	
		FSCQ1265RT	21.2	
		FSCQ1565RT	26.4	
$I_D$	Continuous Drain Current ( $T_C = 25^\circ\text{C}$ ) ( $T_C$ : Case Back Surface Temperature)	FSCQ0565RT	2.8	$A_{(rms)}$
		FSCQ0765RT	3.8	
		FSCQ0965RT	4.1	
		FSCQ1265RT	5.3	
		FSCQ1565RT	6.6	
$I_{D^*}$	Continuous Drain Current* ( $T_{DL} = 25^\circ\text{C}$ ) ( $T_{DL}$ : Drain Lead Temperature)	FSCQ0565RT	5.0	$A_{(rms)}$
		FSCQ0765RT	7.0	
		FSCQ0965RT	7.6	
		FSCQ1265RT	11.0	
		FSCQ1565RT	13.3	
$I_D$	Continuous Drain Current ( $T_C = 100^\circ\text{C}$ )	FSCQ0565RT	1.7	$A_{(rms)}$
		FSCQ0765RT	2.4	
		FSCQ0965RT	2.6	
		FSCQ1265RT	3.4	
		FSCQ1565RT	4.4	
$E_{AS}$	Single-Pulsed Avalanche Energy <sup>(5)</sup>	FSCQ0565RT	400	mJ
		FSCQ0765RT	570	
		FSCQ0965RT	630	
		FSCQ1265RT	950	
		FSCQ1565RT	1050	
$P_D$	Total Power Dissipation ( $T_C = 25^\circ\text{C}$ with Infinite Heat Sink)	FSCQ0565RT	38	W
		FSCQ0765RT	45	
		FSCQ0965RT	49	
		FSCQ1265RT	50	
		FSCQ1565RT	75	
$T_J$	Operating Junction Temperature	150	$^\circ\text{C}$	
$T_A$	Operating Ambient Temperature	-25 to +85	$^\circ\text{C}$	
$T_{STG}$	Storage Temperature Range	-55 to +150	$^\circ\text{C}$	

Continued on the following page...

## Absolute Maximum Ratings

Stresses exceeding the absolute maximum ratings may damage the device. The device may not function or be operable above the recommended operating conditions and stressing the parts to these levels is not recommended. In addition, extended exposure to stresses above the recommended operating conditions may affect device reliability. The absolute maximum ratings are stress ratings only.  $T_A = 25^\circ\text{C}$ , unless otherwise specified.

Symbol	Parameter		Value	Unit
ESD	Human Body Model (All Pins Except $V_{FB}$ )	( $\text{GND} - V_{FB} = 1.7 \text{ kV}$ )	2.0	kV
	Machine Model (All Pins Except $V_{FB}$ )	( $\text{GND} - V_{FB} = 170 \text{ V}$ )	300	V

### Notes:

4. Repetitive rating: pulse width limited by maximum junction temperature.
5.  $L = 15 \text{ mH}$ , starting  $T_J = 25^\circ\text{C}$ . These parameters, although guaranteed by design, are not tested in production.

## Thermal Impedance

$T_A = 25^\circ\text{C}$  unless otherwise specified.

Symbol	Parameter		Value	Unit
$J_C$	Junction-to-Case Thermal Impedance	FSCQ0565RT	3.29	$^\circ\text{C/W}$
		FSCQ0765RT	2.60	
		FSCQ0965RT	2.55	
		FSCQ1265RT	2.50	
		FSCQ1565RT	2.00	

## Electrical Characteristics

T<sub>A</sub> = 25°C unless otherwise specified.

Symbol	Parameter	Condition	Min.	Typ.	Max.	Unit	
<b>SenseFET Part</b>							
BV <sub>DSS</sub>	Drain-Source Breakdown Voltage	V <sub>GS</sub> = 0 V, I <sub>D</sub> = 250 μA	650			V	
I <sub>DSS</sub>	Zero Gate Voltage Drain Current	V <sub>DS</sub> = 650 V, V <sub>GS</sub> = 0 V			250	μA	
R <sub>DS(ON)</sub>	Drain-Source On-State Resistance	FSCQ0565RT	V <sub>GS</sub> = 10 V, I <sub>D</sub> = 1 A		1.76	2.20	Ω
		FSCQ0765RT	V <sub>GS</sub> = 10 V, I <sub>D</sub> = 1 A		1.40	1.60	
		FSCQ0965RT	V <sub>GS</sub> = 10 V, I <sub>D</sub> = 1 A		1.00	1.20	
		FSCQ1265RT	V <sub>GS</sub> = 10 V, I <sub>D</sub> = 1 A		0.75	0.90	
		FSCQ1565RT	V <sub>GS</sub> = 10 V, I <sub>D</sub> = 1 A		0.53	0.70	
C <sub>ISS</sub>	Input Capacitance	FSCQ0565RT	V <sub>GS</sub> = 0 V, V <sub>DS</sub> = 25 V, f = 1 MHz		1080		pF
		FSCQ0765RT			1415		
		FSCQ0965RT			1750		
		FSCQ1265RT			2400		
		FSCQ1565RT			3050		
C <sub>OSS</sub>	Output Capacitance	FSCQ0565RT	V <sub>GS</sub> = 0 V, V <sub>DS</sub> = 25 V, f = 1 MHz		90		pF
		FSCQ0765RT			100		
		FSCQ0965RT			130		
		FSCQ1265RT			175		
		FSCQ1565RT			220		
<b>Control Section</b>							
f <sub>OSC</sub>	Switching Frequency	V <sub>FB</sub> = 5 V, V <sub>CC</sub> = 18 V	18	20	22	kHz	
Δf <sub>OSC</sub>	Switching Frequency Variation <sup>(7)</sup>	-25°C ≤ T <sub>A</sub> ≤ 85°C	0	±5	±10	%	
I <sub>FB</sub>	Feedback Source Current	V <sub>FB</sub> = 0.8 V, V <sub>CC</sub> = 18 V	0.50	0.65	0.80	mA	
D <sub>MAX</sub>	Maximum Duty Cycle	V <sub>FB</sub> = 5 V, V <sub>CC</sub> = 18 V	92	95	98	%	
D <sub>MIN</sub>	Minimum Duty Cycle	V <sub>FB</sub> = 0 V, V <sub>CC</sub> = 18 V		0		%	
V <sub>START</sub>	UVLO Threshold Voltage	V <sub>FB</sub> = 1 V	14	15	16	V	
V <sub>STOP</sub>			8	9	10		
t <sub>SS</sub>	Soft-Start Time <sup>(6)</sup>		18	20	22	ms	
<b>Burst Mode Section</b>							
V <sub>BEN</sub>	Burst Mode Enable Feedback Voltage		0.25	0.40	0.55	V	
I <sub>BFB</sub>	Burst Mode Feedback Source Current	V <sub>FB</sub> = 0 V	60	100	140	μA	
t <sub>BS</sub>	Burst Mode Switching Time	V <sub>FB</sub> = 0.9 V, Duty = 50%	1.2	1.4	1.6	ms	
t <sub>BH</sub>	Burst Mode Hold Time	V <sub>FB</sub> = 0.9 V → 0 V	1.2	1.4	1.6	ms	
<b>Protection Section</b>							
V <sub>SD</sub>	Shutdown Feedback Voltage	V <sub>CC</sub> = 18 V	7.0	7.5	8.0	V	
I <sub>DELAY</sub>	Shutdown Delay Current	V <sub>FB</sub> = 5 V, V <sub>CC</sub> = 18 V	4	5	6	μA	
V <sub>OVP</sub>	Over-Voltage Protection	V <sub>FB</sub> = 3 V	11	12	13	V	
V <sub>OCL</sub>	Over-Current Latch Voltage <sup>(6)</sup>	V <sub>CC</sub> = 18 V	0.9	1.0	1.1	V	
TSD	Thermal Shutdown Temperature <sup>(7)</sup>		140			°C	

Continued on the following page...

## Electrical Characteristics

$T_A = 25^\circ\text{C}$  unless otherwise specified.

Symbol	Parameter	Condition	Min.	Typ.	Max.	Unit	
<b>Sync Section</b>							
$V_{SH1}$	Sync Threshold in Normal QR (H)	$V_{CC} = 18\text{ V}, V_{FB} = 5\text{ V}$	4.2	4.6	5.0	V	
$V_{SL1}$	Sync Threshold in Normal QR (L)		2.3	2.6	2.9	V	
$V_{SH2}$	Sync Threshold in Extended QR (H)		2.7	3.0	3.3	V	
$V_{SL2}$	Sync Threshold in Extended QR (L)		1.6	1.8	2.0	V	
$f_{SYH}$	Extended QR Enable Frequency			90		kHz	
$f_{SYL}$	Extended QR Disable Frequency			45		kHz	
<b>Total Device Section</b>							
$I_{OP}$	Operating Supply Current in Normal Operation <sup>(8)</sup>	FSCQ0565RT	$V_{FB} = 5\text{ V}$		4	6	mA
		FSCQ0765RT			4	6	
		FSCQ0965RT			6	8	
		FSCQ1265RT			6	8	
		FSCQ1565RT			7	9	
$I_{OB}$	Operating Supply Current in Burst Mode (Non-Switching) <sup>(8)</sup>	$V_{FB} = \text{GND}$		0.25	0.50	mA	
$I_{START}$	Startup Current	$V_{CC} = V_{START} - 0.1\text{ V}$		25	50	$\mu\text{A}$	
$I_{SN}$	Sustain Latch Current <sup>(6)</sup>	$V_{CC} = V_{STOP} - 0.1\text{ V}$		50	100	$\mu\text{A}$	
<b>Current Sense Section</b>							
$I_{LIM}$	Maximum Current Limit <sup>(9)</sup>	FSCQ0565RT	$V_{CC} = 18\text{ V}, V_{FB} = 5\text{ V}$	3.08	3.50	3.92	A
		FSCQ0765RT		4.40	5.00	5.60	
		FSCQ0965RT		5.28	6.00	6.72	
		FSCQ1265RT		6.16	7.00	7.84	
		FSCQ1565RT		7.04	8.00	8.96	
$I_{BUR(pk)}$	Burst Peak Current	FSCQ0565RT	$V_{CC} = 18\text{ V}, V_{FB} = \text{Pulse}$	0.45	0.65	0.85	A
		FSCQ0765RT		0.65	0.90	1.15	
		FSCQ0965RT		0.60	0.90	1.20	
		FSCQ1265RT		0.80	1.20	1.60	
		FSCQ1565RT			1.00		

### Notes:

6. These parameters, although guaranteed, are tested only in wafer test process.
7. These parameters, although guaranteed by design, are not tested in production.
8. This parameter is the current flowing in the control IC.
9. These parameters indicate inductor current.
10. These parameters, although guaranteed, are tested only in wafer test process.

## Typical Performance Characteristics

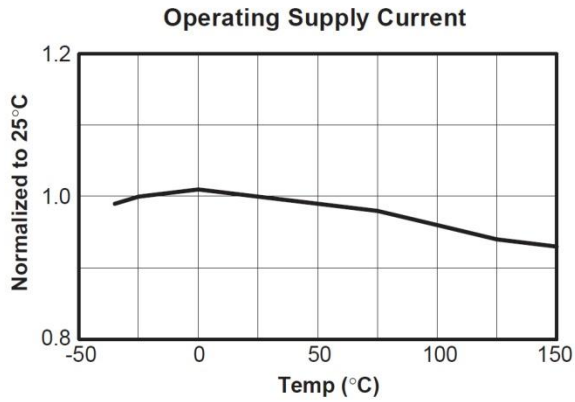

**Figure 4. Operating Supply Current**

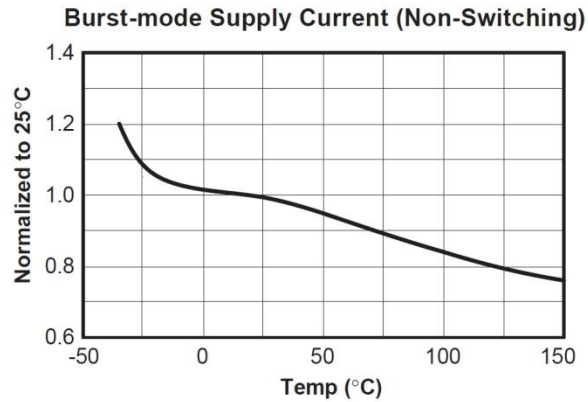

**Figure 5. Burst Mode Supply Current (Non-Switching)**

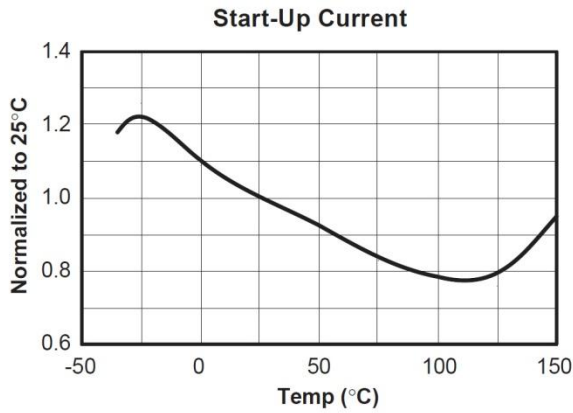

**Figure 6. Startup Current**

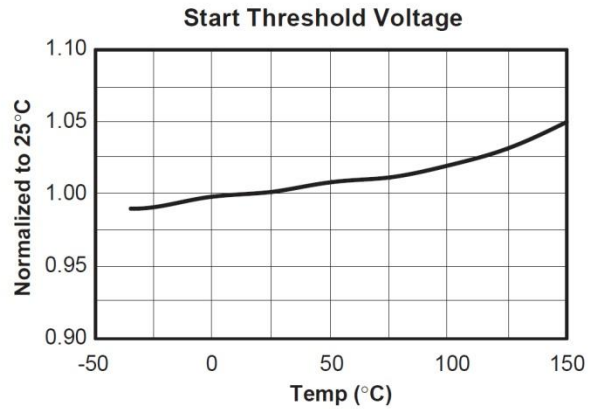

**Figure 7. Start Threshold Voltage**

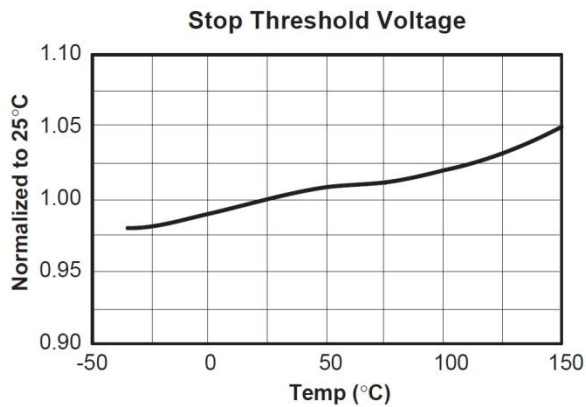

**Figure 8. Stop Threshold Voltage**

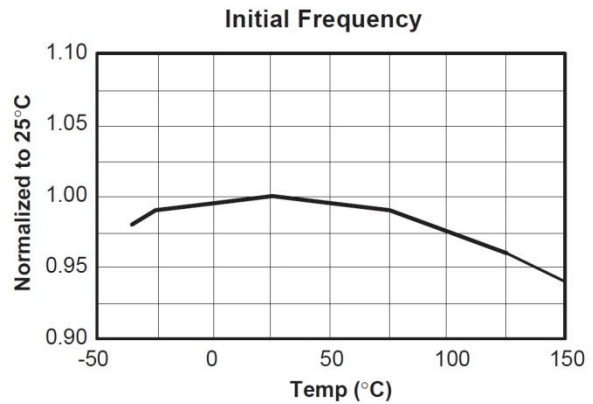

**Figure 9. Initial Frequency**

## Typical Performance Characteristics

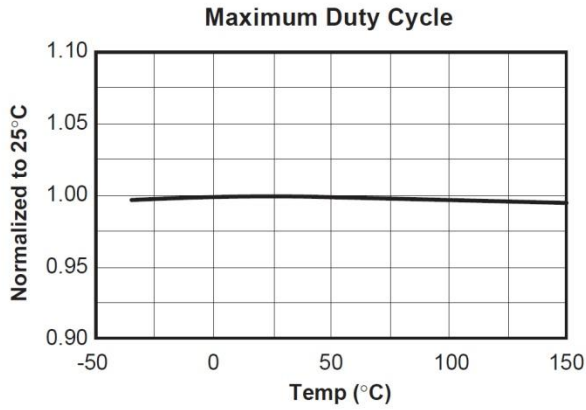

Figure 10. Maximum Duty Cycle

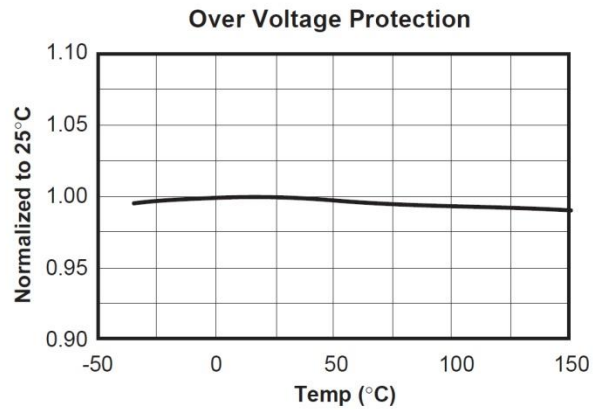

Figure 11. Over-Voltage Protection

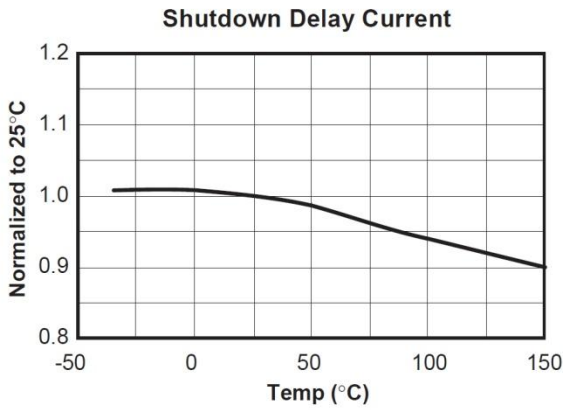

Figure 12. Shutdown Delay Current

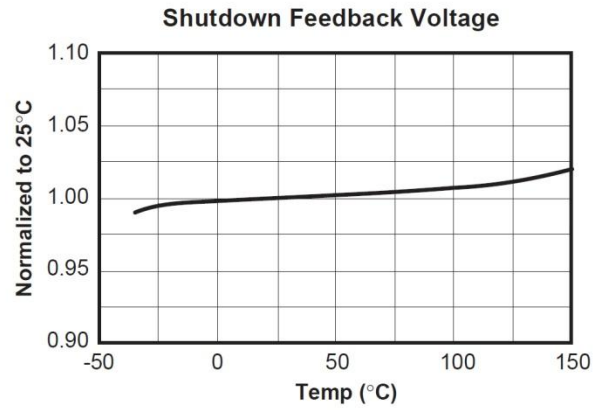

Figure 13. Shutdown Feedback Voltage

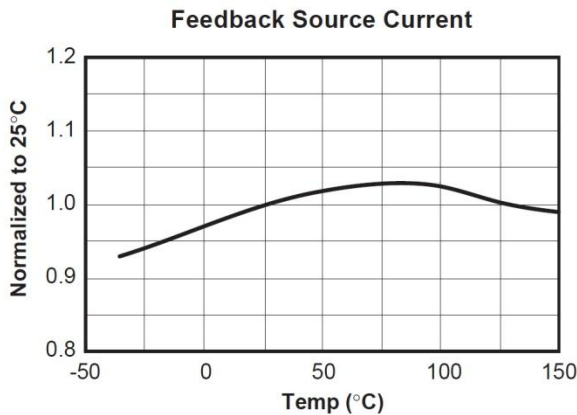

Figure 14. Feedback Source Current

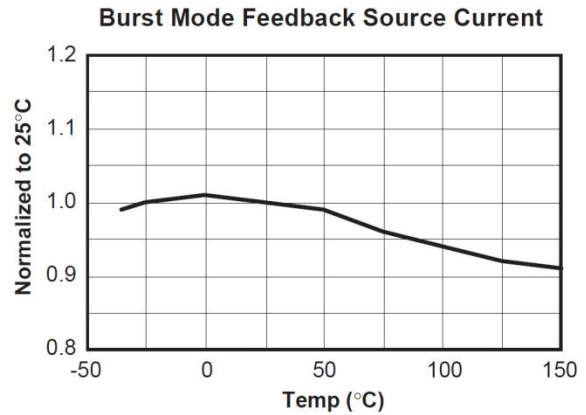

Figure 15. Burst Mode Feedback Source Current

## Typical Performance Characteristics

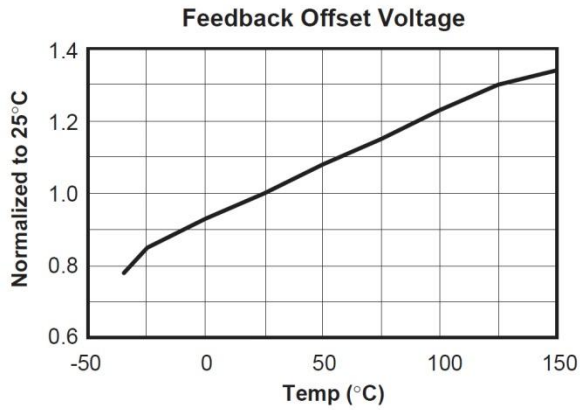

Figure 16. Feedback Offset Voltage

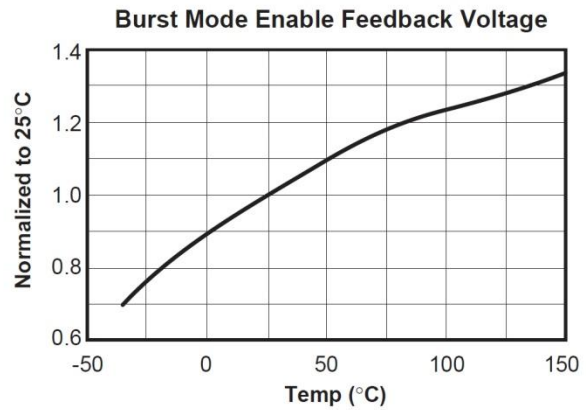

Figure 17. Burst Mode Enable Feedback Voltage

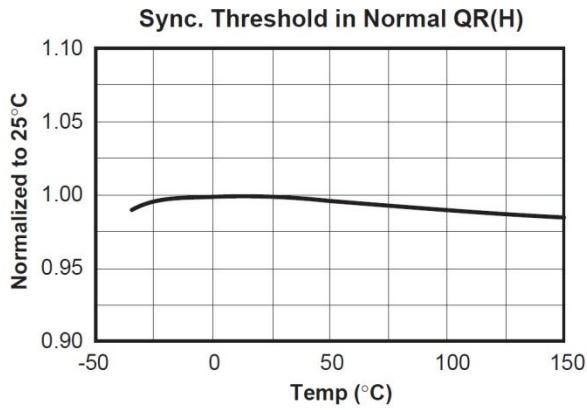

Figure 18. Sync. Threshold in Normal QR(H)

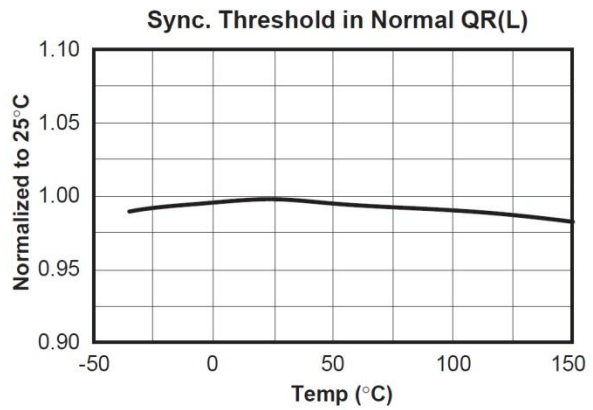

Figure 19. Sync. Threshold in Normal QR(L)

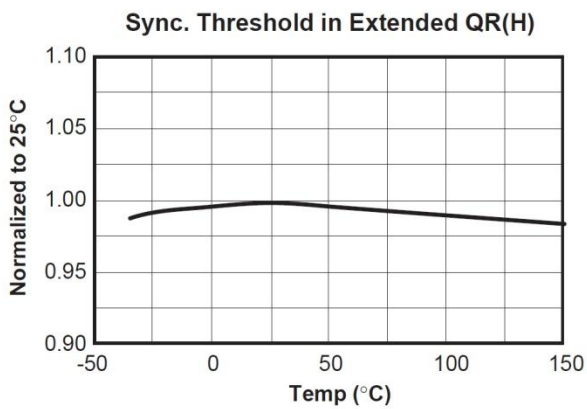

Figure 20. Sync. Threshold in Extended QR(H)

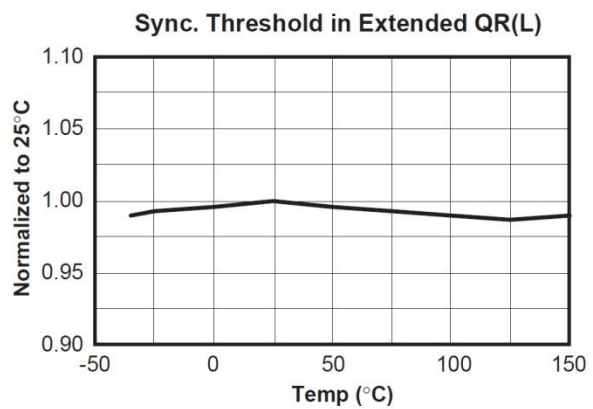

Figure 21. Sync. Threshold in Extended QR(L)

## Typical Performance Characteristics

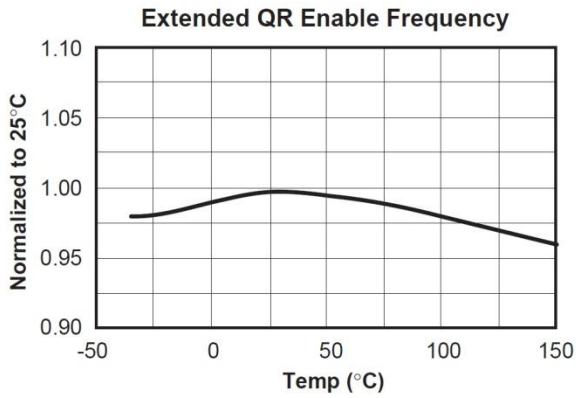

Figure 22. Extended QR Enable Frequency

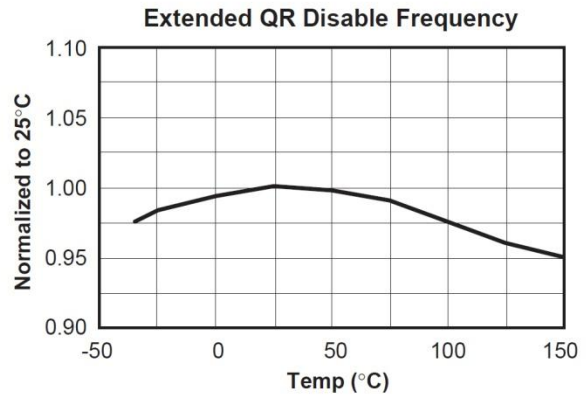

Figure 23. Extended QR Disable Frequency

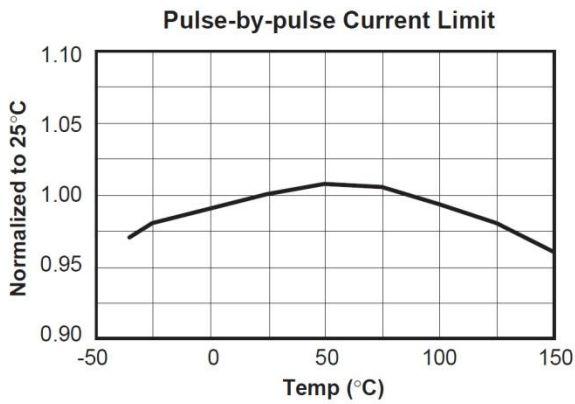
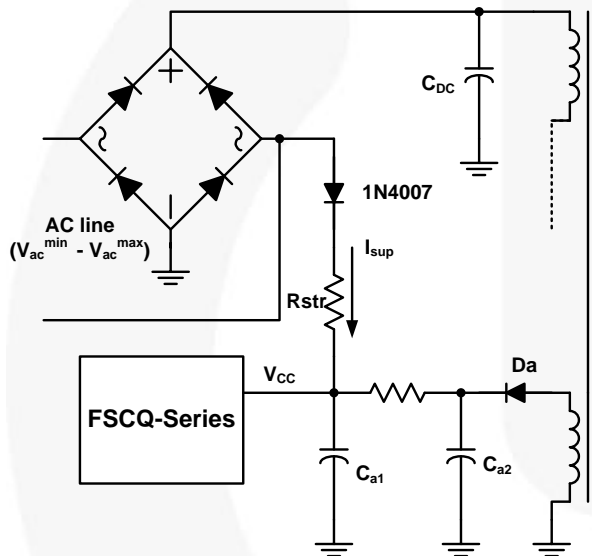

Figure 24. Pulse-by-Pulse Current Limit

## Functional Description

**1. Startup:** Figure 25 shows the typical startup circuit and the transformer auxiliary winding for the FSCQ series. Before the FSCQ series begins switching, it consumes only startup current (typically 25  $\mu$ A). The current supplied from the AC line charges the external capacitor ( $C_{a1}$ ) that is connected to the  $V_{CC}$  pin. When  $V_{CC}$  reaches the start voltage of 15 V ( $V_{START}$ ), the FSCQ series begins switching and its current consumption increases to  $I_{OP}$ . Then, the FSCQ series continues normal switching operation and the power required is supplied from the transformer auxiliary winding, unless  $V_{CC}$  drops below the stop voltage of 9 V ( $V_{STOP}$ ). To guarantee stable operation of the control IC,  $V_{CC}$  has under-voltage lockout (UVLO) with 6 V hysteresis. Figure 26 shows the relationship between the operating supply current of the FSCQ series and the supply voltage ( $V_{CC}$ ).



**Figure 25. Startup Circuit**

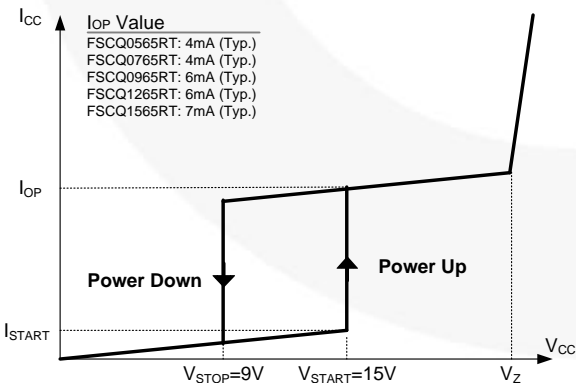

**Figure 26. Relationship between Operating Supply Current and  $V_{CC}$  Voltage**

The minimum average of the current supplied from the AC is given by:

$$I_{SUP}^{AVG} = \left( \frac{\sqrt{2 \cdot V_{AC}^{MIN}}}{\pi} - \frac{V_{START}}{2} \right) \cdot \frac{1}{R_{STR}} \quad (1)$$

where  $V_{ac}^{min}$  is the minimum input voltage,  $V_{START}$  is the FSCQ series' start voltage (15 V), and  $R_{str}$  is the startup resistor. The startup resistor should be chosen so that  $I_{sup}^{avg}$  is larger than the maximum startup current (50  $\mu$ A).

Once the resistor value is determined, the maximum loss in the startup resistor is obtained as:

$$Loss = \frac{1}{R_{STR}} \cdot \left( \frac{(V_{AC}^{MAX})^2}{2} + V_{START}^2 - \frac{2\sqrt{2} \cdot V_{START} \cdot V_{AC}^{MAX}}{\pi} \right) \quad (2)$$

where  $V_{ac}^{max}$  is the maximum input voltage.

The startup resistor should have properly rated dissipation wattage.

**2. Synchronization:** The FSCQ series employs a quasi-resonant switching technique to minimize the switching noise and loss. In this technique, a capacitor ( $C_r$ ) is added between the MOSFET drain and the source, as shown in Figure 27. The basic waveforms of the quasi-resonant converter are shown in Figure 28. The external capacitor lowers the rising slope of the drain voltage to reduce the EMI caused when the MOSFET turns off. To minimize the MOSFET's switching loss, the MOSFET should be turned on when the drain voltage reaches its minimum value, as shown in Figure 28.

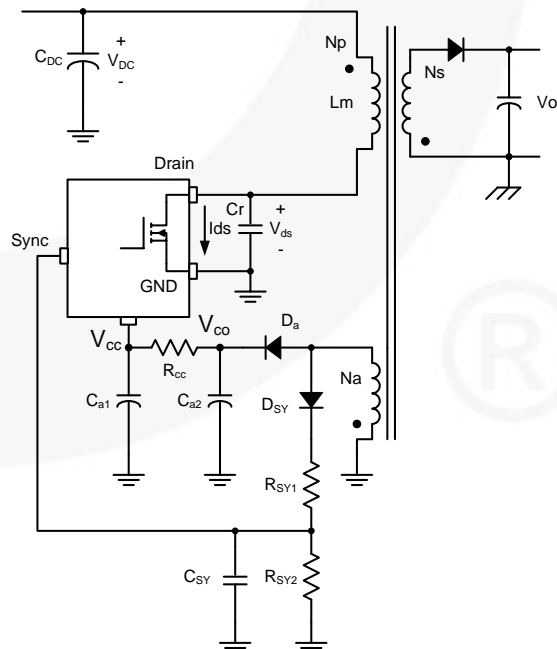

**Figure 27. Synchronization Circuit**

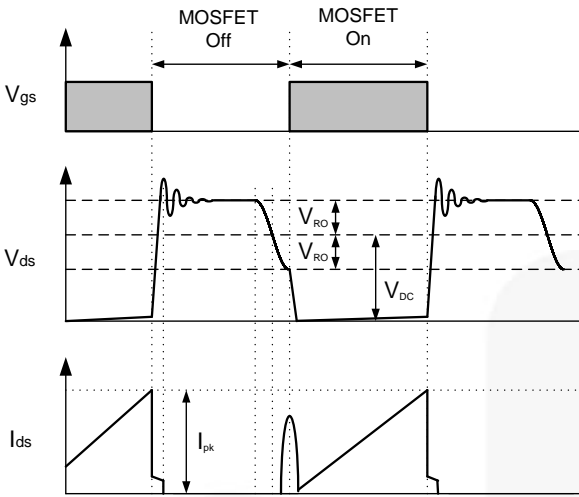

**Figure 28. Quasi-Resonant Operation Waveforms**

The minimum drain voltage is indirectly detected by monitoring the  $V_{CC}$  winding voltage, as shown in Figure 27 and Figure 29. Choose voltage dividers,  $R_{SY1}$  and  $R_{SY2}$ , so that the peak voltage of the sync signal ( $V_{syPk}$ ) is lower than the OVP voltage (12 V) to avoid triggering OVP in normal operation. It is typical to set  $V_{syPk}$  to be lower than OVP voltage by 3–4 V. To detect the optimum time to turn on MOSFET, the sync capacitor ( $C_{SY}$ ) should be determined so that  $t_R$  is the same with  $t_Q$ , as shown in Figure 29. The  $t_R$  and  $t_Q$  are given as:

$$t_R = R_{SY2} \cdot C_{SY} \cdot \ln \left( \frac{V_{CO}}{2.6} \cdot \frac{R_{SY2}}{R_{SY1} + R_{SY2}} \right) \quad (3)$$

$$t_Q = \pi \cdot \sqrt{L_m \cdot C_{eo}} \quad (4)$$

$$V_{CO} = \frac{N_a \cdot (V_o + V_{FO})}{N_s} - V_{Fa} \quad (5)$$

where:

$L_m$  is the primary side inductance of the transformer;

$N_s$  is the number of turns for the output winding;

$N_a$  is the number of turns for the  $V_{CC}$  winding;

$V_{FO}$  is the diode forward-voltage drop of the output winding;

$V_{Fa}$  is the diode forward-voltage drop of the  $V_{CC}$  winding; and

$C_{eo}$  is the sum of the output capacitance of the MOSFET and the external capacitor,  $C_r$ .

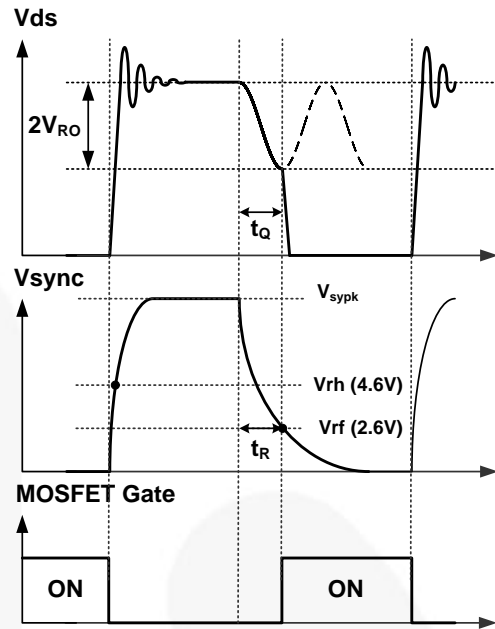

**Figure 29. Normal QR Operation Waveforms**

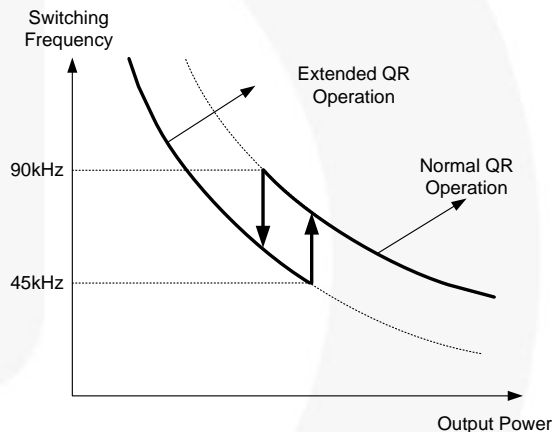

**Figure 30. Extended Quasi-Resonant Operation**

In general, the QRC has a limitation in a wide load range application, since the switching frequency increases as the output load decreases, resulting in a severe switching loss in the light load condition. To overcome this limitation, the FSCQ series employs an extended quasi-resonant switching operation. Figure 30 shows the mode change between normal and extended quasi-resonant operations. In the normal quasi-resonant operation, the FSCQ series enters into the extended quasi-resonant operation when the switching frequency exceeds 90 kHz as the load reduces. To reduce the switching frequency, the MOSFET is turned on when the drain voltage reaches the second minimum level, as shown in Figure 31. Once the FSCQ series enters into the extended quasi-resonant operation, the first sync signal is ignored. After the first sync signal is applied, the sync threshold levels are changed from 4.6 V and 2.6 V to 3 V and 1.8 V, respectively, and the MOSFET turn-on time is synchronized to the second sync signal. The FSCQ series returns to its normal quasi-resonant operation when the switching frequency reaches 45 kHz as the load increases.

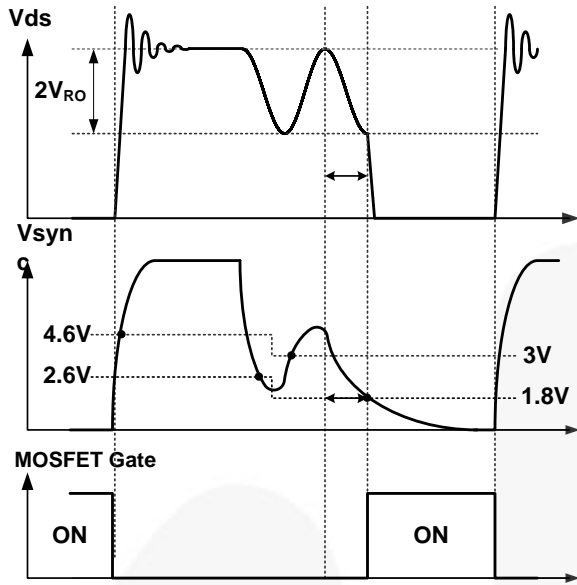

Figure 31. Extended QR Operation Waveforms

**3. Feedback Control:** The FSCQ series employs current mode control, as shown in Figure 32. An optocoupler (such as Fairchild's H11A817A) and shunt regulator (such as Fairchild's KA431) are typically used to implement the feedback network. Comparing the feedback voltage with the voltage across the  $R_{sense}$  resistor, plus an offset voltage, makes it possible to control the switching duty cycle. When the reference pin voltage of the shunt regulator exceeds the internal reference voltage of 2.5 V, the opto-coupler LED current increases, pulling down the feedback voltage and reducing the duty cycle. This typically occurs when input voltage is increased or output load is decreased.

**3.1 Pulse-by-Pulse Current Limit:** Because current mode control is employed, the peak current through the SenseFET is limited by the inverting input of the PWM comparator ( $V_{fb}^*$ ) as shown in Figure 32. The feedback current ( $I_{FB}$ ) and internal resistors are designed so that the maximum cathode voltage of diode  $D_2$  is about 2.8 V, which occurs when all IFB flows through the internal resistors. Since  $D_1$  is blocked when the feedback voltage ( $V_{fb}$ ) exceeds 2.8 V, the maximum voltage of the cathode of  $D_2$  is clamped at this voltage, thus clamping  $V_{fb}^*$ . Therefore, the peak value of the current through the SenseFET is limited.

**3.2 Leading Edge Blanking (LEB):** At the instant the internal SenseFET is turned on, there is usually a high current spike through the SenseFET, caused by the external resonant capacitor across the MOSFET and secondary-side rectifier reverse recovery. Excessive voltage across the  $R_{sense}$  resistor can lead to incorrect feedback operation in the current mode PWM control. To counter this effect, the FSCQ series employs a leading edge blanking (LEB) circuit. This circuit inhibits the PWM comparator for a short time ( $t_{LEB}$ ) after the Sense FET is turned on.

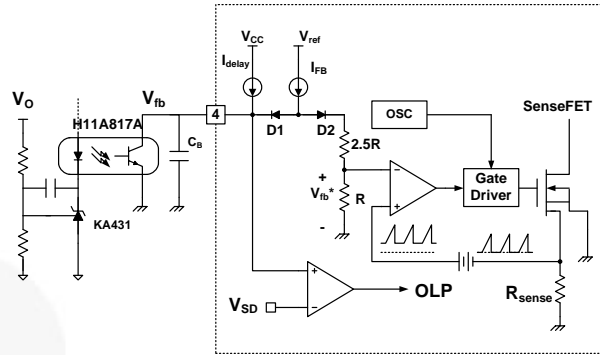
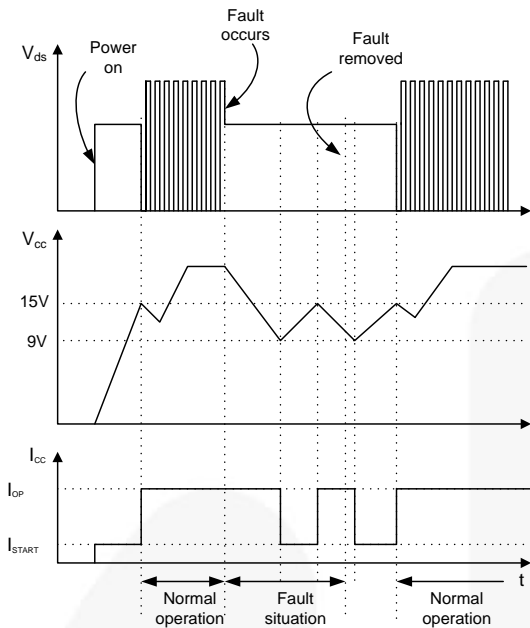

Figure 32. Pulse Width Modulation (PWM) Circuit

**4. Protection Circuits:** The FSCQ series has several self-protective functions such as overload protection (OLP), abnormal over-current protection (AOCP), over-voltage protection (OVP), and thermal shutdown (TSD). OLP and OVP are auto-restart mode protections, while TSD and AOCP are latch mode protections. Because these protection circuits are fully integrated into the IC without external components, the reliability can be improved without increasing cost.

- **Auto-Restart Mode Protection:** Once the fault condition is detected, switching is terminated and the SenseFET remains off. This causes  $V_{CC}$  to fall. When  $V_{CC}$  falls to the under voltage lockout (UVLO) stop voltage of 9 V, the protection is reset and the FSCQ series consumes only startup current (25  $\mu$ A). Then, the  $V_{CC}$  capacitor is charged up, since the current supplied through the startup resistor is larger than the current that the FPS consumes. When  $V_{CC}$  reaches the start voltage of 15 V, the FSCQ series resumes its normal operation. If the fault condition is not removed, the SenseFET remains off and  $V_{CC}$  drops to stop voltage again. In this manner, the auto-restart can alternately enable and disable the switching of the power SenseFET until the fault condition is eliminated (see Figure 33).
- **Latch Mode Protection:** Once this protection is triggered, switching is terminated and the SenseFET remains off until the AC power line is unplugged. Then,  $V_{CC}$  continues charging and discharging between 9 V and 15 V. The latch is reset only when  $V_{CC}$  is discharged to 6 V by unplugging the AC power line.



**Figure 33. Auto Restart Mode Protection**

**4.1 Overload Protection (OLP):** Overload is defined as the load current exceeding its normal level due to an unexpected abnormal event. In this situation, the protection circuit should trigger to protect the SMPS. However, even when the SMPS is in the normal operation, the over load protection circuit can be triggered during the load transition. To avoid this undesired operation, the overload protection circuit is designed to trigger after a specified time to determine whether it is a transient situation or an overload situation. Because of the pulse-by-pulse current limit capability, the maximum peak current through the SenseFET is limited, and therefore the maximum input power is restricted with a given input voltage. If the output consumes more than this maximum power, the output voltage ( $V_o$ ) decreases below the set voltage. This reduces the current through the opto-coupler LED, which also reduces the opto-coupler transistor current, thus increasing the feedback voltage ( $V_{fb}$ ). If  $V_{fb}$  exceeds 2.8 V,  $D_1$  is blocked, and the 5  $\mu$ A current source starts to charge  $C_B$  slowly up to  $V_{CC}$ . In this condition,  $V_{fb}$  continues increasing until it reaches 7.5 V, then the switching operation is terminated as shown in Figure 34. The delay for shutdown is the time required to charge  $C_B$  from 2.8 V to 7.5 V with 5  $\mu$ A. In general, a 20–50 ms delay is typical for most applications. OLP is implemented in auto restart mode.

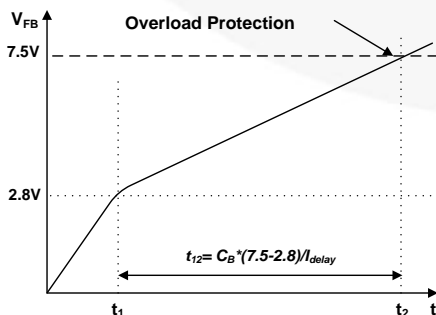

**Figure 34. Overload Protection**

**4.2 Abnormal Over Current Protection (AOCP):** When the secondary rectifier diodes or the transformer pins are shorted, a steep current with extremely high di/dt can flow through the SenseFET during the LEB time. Even though the FSCQ series has OLP (Overload Protection), it is not enough to protect the FSCQ series in that abnormal case, since severe current stress will be imposed on the SenseFET until the OLP triggers. The FSCQ series has an internal AOCP (Abnormal Over-Current Protection) circuit as shown in Figure 35. When the gate turn-on signal is applied to the power SenseFET, the AOCP block is enabled and monitors the current through the sensing resistor. The voltage across the resistor is then compared with a preset AOCP level. If the sensing resistor voltage is greater than the AOCP level, the set signal is applied to the latch, resulting in the shutdown of SMPS. This protection is implemented in the latch mode.

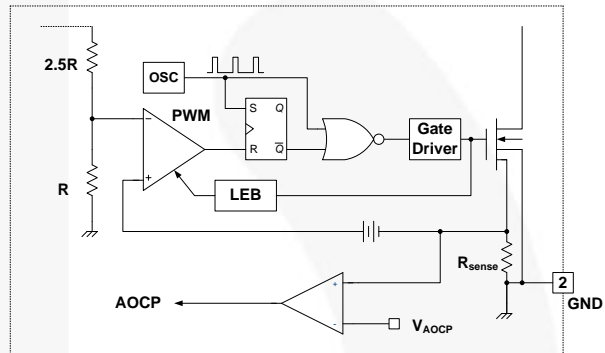

**Figure 35. AOCP Block**

**4.3 Over-Voltage Protection (OVP):** If the secondary side feedback circuit malfunctions or a solder defect causes an open in the feedback path, the current through the opto-coupler transistor becomes almost zero. Then,  $V_{fb}$  climbs up in a similar manner to the over load situation, forcing the preset maximum current to be supplied to the SMPS until the over load protection triggers. Because more energy than required is provided to the output, the output voltage may exceed the rated voltage before the overload protection triggers, resulting in the breakdown of the devices in the secondary side. In order to prevent this situation, an over voltage protection (OVP) circuit is employed. In general, the peak voltage of the sync signal is proportional to the output voltage and the FSCQ series uses a sync signal instead of directly monitoring the output voltage. If the sync signal exceeds 12 V, an OVP is triggered resulting in a shutdown of SMPS. In order to avoid undesired triggering of OVP during normal operation, the peak voltage of the sync signal should be designed to be below 12 V. This protection is implemented in the auto restart mode.

**4.4 Thermal Shutdown (TSD):** The SenseFET and the control IC are built in one package. This makes it easy for the control IC to detect abnormal over temperature of the SenseFET. When the temperature exceeds approximately 150°C, the thermal shutdown triggers. This protection is implemented in the latch mode.

**5. Soft Start:** The FSCQ series has an internal soft-start circuit that increases PWM comparator's inverting input voltage together with the SenseFET current slowly after it starts up. The typical soft start time is 20 ms. The pulse width to the power switching device is progressively increased to establish the correct working conditions for transformers, inductors, and capacitors. Increasing the pulse width to the power switching device also helps prevent transformer saturation and reduces the stress on the secondary diode during startup. For a fast build up of the output voltage, an offset is introduced in the soft-start reference current.

**6. Burst Operation:** To minimize the power consumption in the standby mode, the FSCQ series employs burst operation. Once FSCQ series enters burst mode, FSCQ series allows all output voltages and effective switching frequency to be reduced. Figure 36 shows the typical feedback circuit for C-TV applications. In normal operation, the picture on signal is applied and the transistor Q<sub>1</sub> is turned on, which decouples R<sub>3</sub>, D<sub>Z</sub> and D<sub>1</sub> from the feedback network. Therefore, only V<sub>O1</sub> is regulated by the feedback circuit in normal operation and determined by R<sub>1</sub> and R<sub>2</sub> as:

$$V_{O1}^{NORM} = 2.5 \cdot \left( \frac{R_1 + R_2}{R_2} \right) \quad (6)$$

In standby mode, the picture ON signal is disabled and the transistor Q<sub>1</sub> is turned off, which couples R<sub>3</sub>, D<sub>Z</sub>, and D<sub>1</sub> to the reference pin of KA431. Then, V<sub>O2</sub> is determined by the Zener diode breakdown voltage. Assuming that the forward voltage drop of D<sub>1</sub> is 0.7V, V<sub>O2</sub> in standby mode is approximately given by:

$$V_{O2}^{STBY} = V_Z + 0.7 + 2.5 \quad (7)$$

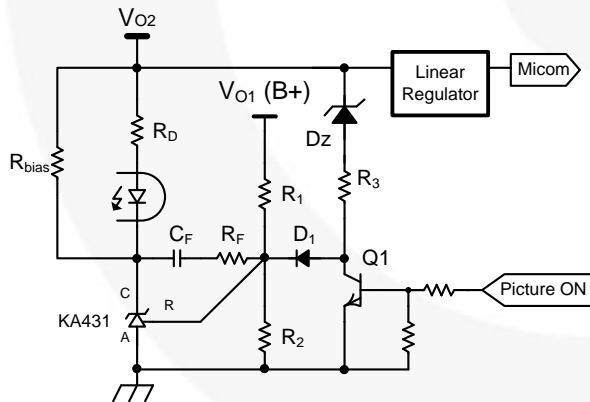

**Figure 36. Typical Feedback Circuit to Drop Output Voltage in Standby Mode**

Figure 38 shows the burst mode operation waveforms. When the picture ON signal is disabled, Q<sub>1</sub> is turned off and R<sub>3</sub> and D<sub>Z</sub> are connected to the reference pin of KA431 through D<sub>1</sub>. Before V<sub>O2</sub> drops to V<sub>O2</sub><sup>stby</sup>, the voltage on the reference pin of KA431 is higher than 2.5 V, which increases the current through the opto LED. This pulls down the feedback voltage (V<sub>FB</sub>) of FSCQ series and forces FSCQ series to stop switching. If the switching is disabled longer than 1.4 ms, FSCQ series enters into burst operation and the operating current is reduced from I<sub>OP</sub> to 0.25 mA (I<sub>OB</sub>). Since there is no switching, V<sub>O2</sub> decreases until it reaches V<sub>O2</sub><sup>stby</sup>. As V<sub>O2</sub> reaches V<sub>O2</sub><sup>stby</sup>, the current through the opto LED decreases allowing the feedback voltage to rise. When the feedback voltage reaches 0.4 V, FSCQ series resumes switching with a predetermined peak drain current of 0.9 A. After burst switching for 1.4 ms, FSCQ series stops switching and checks the feedback voltage. If the feedback voltage is below 0.4 V, FSCQ series stops switching until the feedback voltage increases to 0.4 V. If the feedback voltage is above 0.4 V, FSCQ series goes back to the normal operation. The output voltage drop circuit can be implemented alternatively, as shown in Figure 37. In the circuit, the FSCQ series goes into burst mode, when picture off signal is applied to Q<sub>1</sub>. Then, V<sub>O2</sub> is determined by the Zener diode breakdown voltage. Assuming that the forward voltage drop of opto LED is 1 V, the approximate value of V<sub>O2</sub> in standby mode is given by:

$$V_{O2}^{STBY} = V_Z + 1 \quad (8)$$

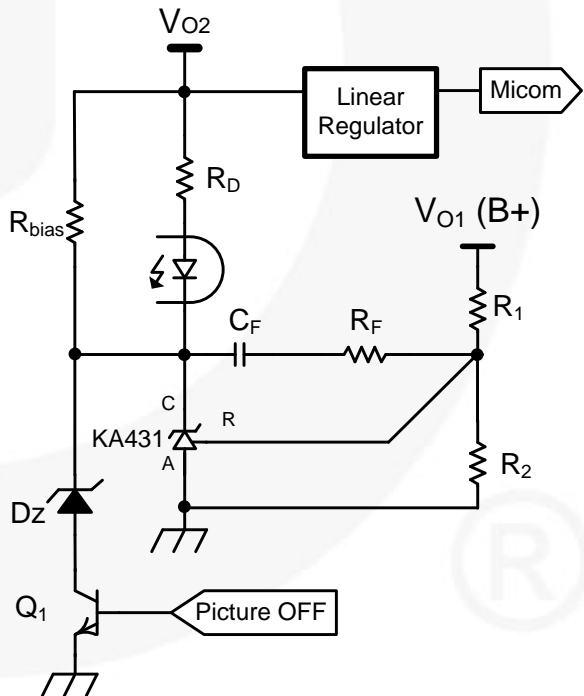

**Figure 37. Feedback Circuit to Drop Output Voltage in Standby Mode**

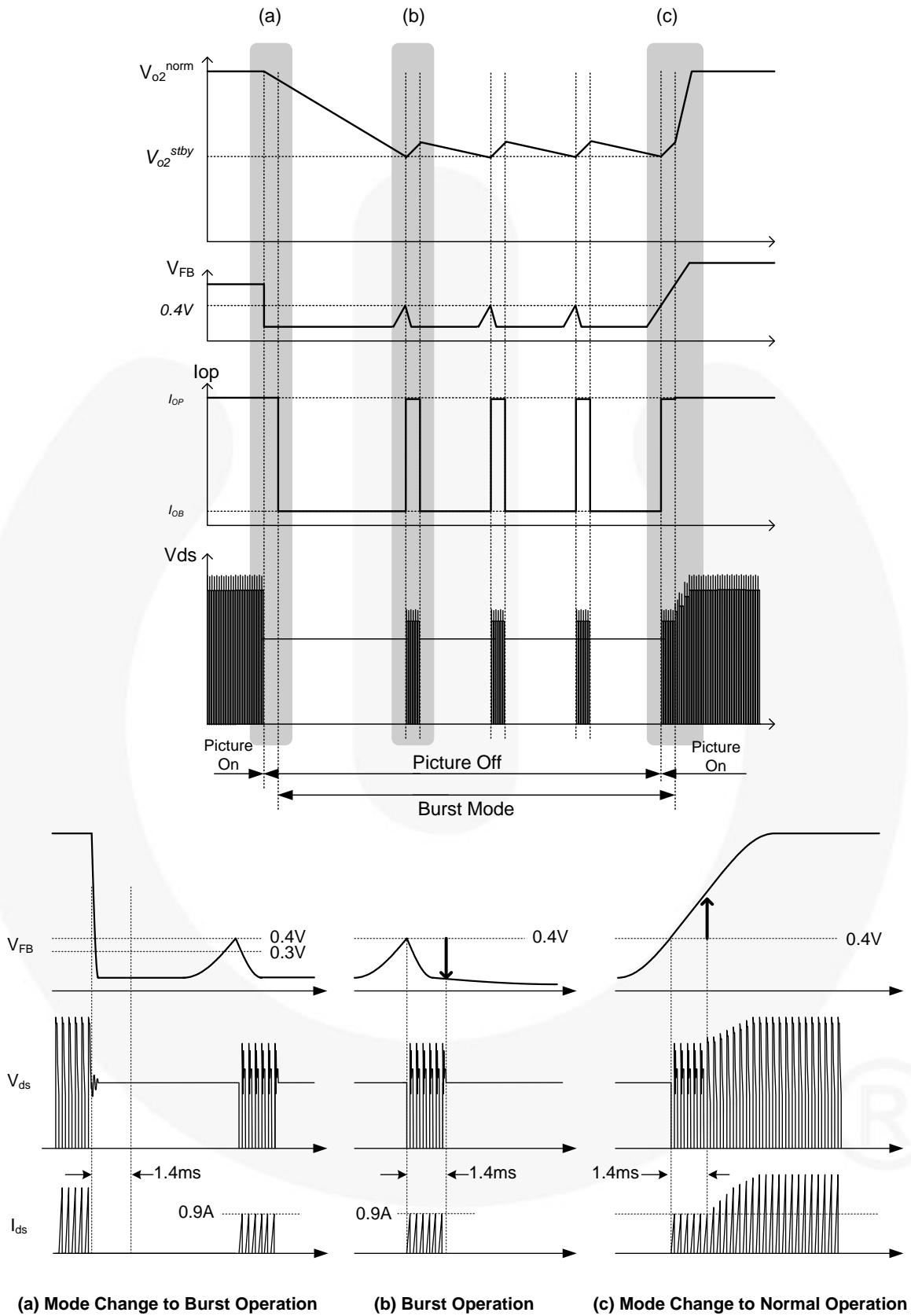

Figure 38. Burst Operation Waveforms

## FSCQ0565RT Typical Application Circuit

Application	Output Power	Input Voltage	Output Voltage (Max. Current)
C-TV	59 W	Universal Input (90–270 V <sub>ac</sub> )	12 V (0.5 A)
			18 V (0.3 A)
			125 V (0.3 A)
			24 V (0.4 A)

### Features

- High Efficiency (>83% at 90 V<sub>ac</sub> Input)
- Wider Load Range through the Extended Quasi-Resonant Operation
- Low Standby Mode Power Consumption (<1 W)
- Low Component Count
- Enhanced System Reliability Through Various Protection Functions
- Internal Soft-Start (20 ms)

### Key Design Notes

- 24 V Output Designed to Drop to 8 V in Standby Mode

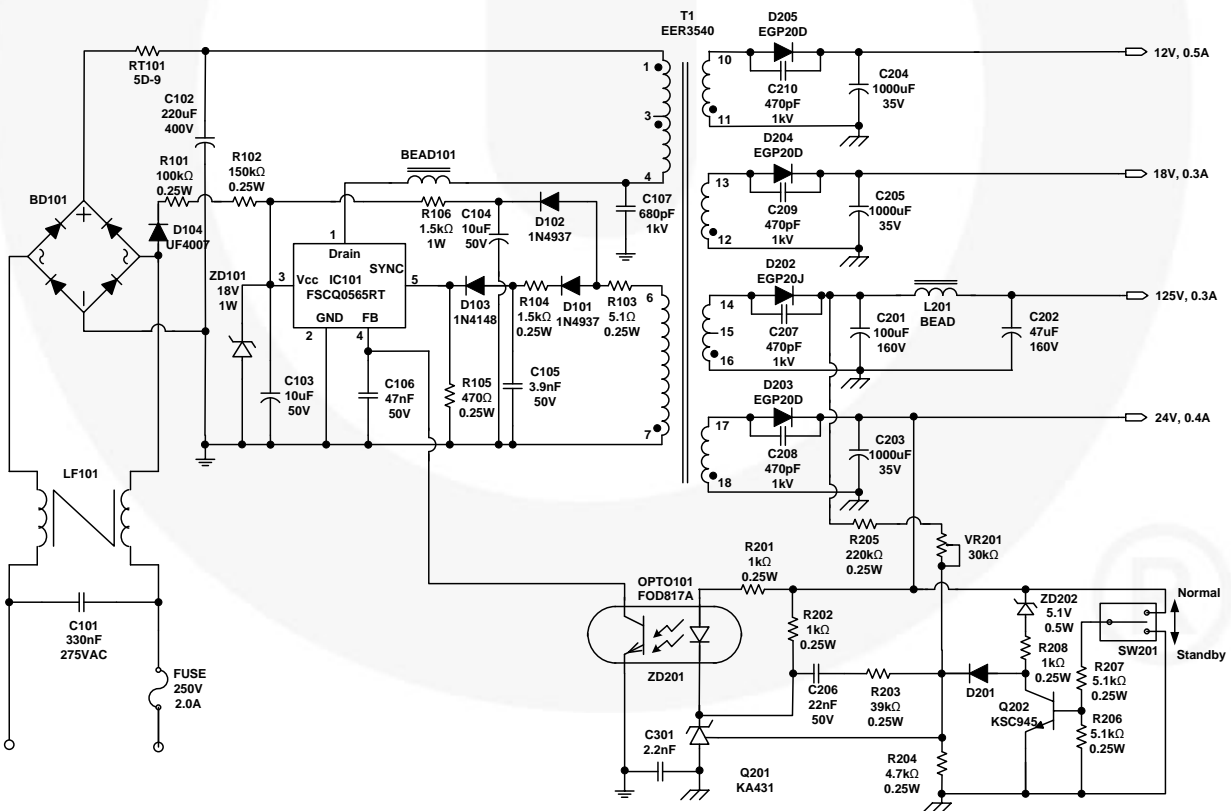

Figure 39. FSCQ0565RT Typical Application Circuit Schematic

### FSCQ0565RT Typical Application Circuit (Continued)



Figure 40. Transformer Schematic Diagram

### Winding Specification

No	Pin (s→f)	Wire	Turns	Winding Method
N <sub>p1</sub>	1–3	0.5φ × 1	32	Center Winding
N <sub>125V/2</sub>	16–15	0.5φ × 1	32	Center Winding
N <sub>24V</sub>	18–17	0.4φ × 2	13	Center Winding
N <sub>12V</sub>	12–13	0.5φ × 2	7	Center Winding
N <sub>p2</sub>	3–4	0.5φ × 1	32	Center Winding
N <sub>125V/2</sub>	15–14	0.5φ × 1	32	Center Winding
N <sub>18V</sub>	11–10	0.4φ × 2	10	Center Winding
N <sub>a</sub>	7–6	0.3φ × 1	20	Center Winding

### Electrical Characteristics

	Pin	Specification	Remarks
Inductance	1–3	740 μH ±5%	1 kHz, 1 V
Leakage Inductance	1–3	10 μH Max.	2nd all short

### Core & Bobbin

- Core: EER3540
- Bobbin: EER3540
- Ae: 107 mm<sup>2</sup>

## Bill of Materials

Part	Value	Note
<b>Fuse</b>		
FUSE	250 V / 2 A	
<b>NTC</b>		
RT101	5D-9	
<b>Resistor</b>		
R101	100 k $\Omega$	0.25 W
R102	150 k $\Omega$	0.25 W
R103	5.1 $\Omega$	0.25 W
R104	1.5 k $\Omega$	0.25 W
R105	470 $\Omega$	0.25 W
R106	1.5 k $\Omega$	1 W
R107	Open	
R201	1 k $\Omega$	0.25 W
R202	1 k $\Omega$	0.25 W
R203	39 k $\Omega$	0.25 W
R204	4.7 k $\Omega$	0.25 W, 1%
R205	220 k $\Omega$	0.25 W, 1%
R206	5.1 k $\Omega$	0.25 W
R207	5.1 k $\Omega$	0.25 W
R208	1 k $\Omega$	0.25 W
VR201	30 k $\Omega$	
<b>Capacitor</b>		
C101	330 nF / 275 V <sub>AC</sub>	
C102	220 $\mu$ F / 400 V	Box Capacitor
C103	10 $\mu$ F / 50 V	Electrolytic
C104	10 $\mu$ F / 50 V	Electrolytic
C105	3.9 nF / 50 V	Electrolytic
C106	47 nF / 50 V	Film Capacitor
C107	680 pF / 1 kV	Film Capacitor
C108	Open	
C201	100 $\mu$ F / 160 V	Electrolytic
C202	47 $\mu$ F / 160 V	Electrolytic
C203	1000 $\mu$ F / 35 V	Electrolytic
C204	1000 $\mu$ F / 35 V	Electrolytic
C205	1000 $\mu$ F / 35 V	Electrolytic
C206	22 nF / 50 V	Film Capacitor
C207	470 pF / 1 kV	Ceramic Capacitor
C208	470 pF / 1 kV	Ceramic Capacitor
C209	470 pF / 1 kV	Ceramic Capacitor
C210	470 pF / 1 kV	Ceramic Capacitor
C301	2.2 nF / 1 kV	AC Ceramic Capacitor

Part	Value	Note
<b>Inductor</b>		
BEAD101	BEAD	
BEAD201	5 $\mu$ H	3 A
<b>Diode</b>		
D101	1N4937	1 A, 600 V
D102	1N4937	1 A, 600 V
D103	1N4148	0.15 A, 50 V
D104	Short	
D105	Open	
ZD101	1N4746	18 V, 1 W
ZD102	Open	
ZD201	1N5231	5.1 V, 0.5 W
D201	1N4148	0.15 A, 50 V
D202	EGP20J	2 A, 600 V
D203	EGP20D	2 A, 200 V
D204	EGP20D	2 A, 200 V
D205	EGP20D	2 A, 200 V
<b>Bridge Diode</b>		
BD101	GSIB660	6 A, 600 V
<b>Line Filter</b>		
LF101		14 mH
<b>Transformer</b>		
T101	EER3540	
<b>Switch</b>		
SW201	ON/OFF	For MCU Signal
<b>IC</b>		
IC101	FSCQ0565RT	TO-220F-5L
OPT101	FOD817A	
Q201	KA431LZ	TO-92
Q202	KSC945	



## FSCQ0765RT Typical Application Circuit (Continued)



Figure 42. Transformer Schematic Diagram

### Winding Specification

No	Pin (s→f)	Wire	Turns	Winding Method
N <sub>p1</sub>	1–3	0.5φ × 1	32	Center Winding
N <sub>125V/2</sub>	16–15	0.5φ × 1	32	Center Winding
N <sub>24V</sub>	18–17	0.4φ × 2	13	Center Winding
N <sub>12V</sub>	12–13	0.5φ × 2	7	Center Winding
N <sub>p2</sub>	3–4	0.5φ × 1	32	Center Winding
N <sub>125V/2</sub>	15–14	0.5φ × 1	32	Center Winding
N <sub>18V</sub>	11–10	0.4φ × 2	10	Center Winding
N <sub>a</sub>	7–6	0.3φ × 1	20	Center Winding

### Electrical Characteristics

	Pin	Specification	Remarks
Inductance	1–3	515 μH ±5%	1 kHz, 1 V
Leakage Inductance	1–3	10 μH Max.	2nd all short

### Core & Bobbin

- Core: EER3540
- Bobbin: EER3540
- Ae: 107 mm<sup>2</sup>

## Bill of Materials

Part	Value	Note
<b>Fuse</b>		
FUSE	250 V / 2 A	
<b>NTC</b>		
RT101	5D-9	
<b>Resistor</b>		
R101	100 k $\Omega$	0.25 W
R102	150 k $\Omega$	0.25 W
R103	5.1 $\Omega$	0.25 W
R104	1.5 k $\Omega$	0.25 W
R105	470 $\Omega$	0.25 W
R106	1.5 k $\Omega$	1 W
R107	Open	
R201	1 k $\Omega$	0.25 W
R202	1 k $\Omega$	0.25 W
R203	39 k $\Omega$	0.25 W
R204	4.7 k $\Omega$	0.25 W, 1%
R205	220 k $\Omega$	0.25 W, 1%
R206	5.1 k $\Omega$	0.25 W
R207	5.1 k $\Omega$	0.25 W
R208	1 k $\Omega$	0.25 W
VR201	30 k $\Omega$	
<b>Capacitor</b>		
C101	330 nF / 275 V <sub>AC</sub>	
C102	220 $\mu$ F / 400 V	Box Capacitor
C103	10 $\mu$ F / 50 V	Electrolytic
C104	10 $\mu$ F / 50 V	Electrolytic
C105	3.9 nF / 50 V	Electrolytic
C106	47 nF / 50 V	Film Capacitor
C107	680 pF / 1 kV	Film Capacitor
C108	Open	
C201	100 $\mu$ F / 160 V	Electrolytic
C202	47 $\mu$ F / 160 V	Electrolytic
C203	1000 $\mu$ F / 35 V	Electrolytic
C204	1000 $\mu$ F / 35 V	Electrolytic
C205	1000 $\mu$ F / 35 V	Electrolytic
C206	22 nF / 50 V	Film Capacitor
C207	470 pF / 1 kV	Ceramic Capacitor
C208	470 pF / 1 kV	Ceramic Capacitor
C209	470 pF / 1 kV	Ceramic Capacitor
C210	470 pF / 1 kV	Ceramic Capacitor
C301	2.2 nF / 1 kV	AC Ceramic Capacitor

Part	Value	Note
<b>Inductor</b>		
BEAD101	BEAD	
BEAD201	5 $\mu$ H	3 A
<b>Diode</b>		
D101	1N4937	1 A, 600 V
D102	1N4937	1 A, 600 V
D103	1N4148	0.15 A, 50 V
D104	Short	
D105	Open	
ZD101	1N4746	18 V, 1 W
ZD102	Open	
ZD201	1N5231	5.1 V, 0.5 W
D201	1N4148	0.15 A, 50 V
D202	EGP20J	2 A, 600 V
D203	EGP20D	2 A, 200 V
D204	EGP20D	2 A, 200 V
D205	EGP20D	2 A, 200 V
<b>Bridge Diode</b>		
BD101	GSIB660	6 A, 600 V
<b>Line Filter</b>		
LF101		14 mH
<b>Transformer</b>		
T101	EER3540	
<b>Switch</b>		
SW201	ON/OFF	For MCU Signal
<b>IC</b>		
IC101	FSCQ0765RT	TO-220F-5L
OPT101	FOD817A	
Q201	KA431LZ	TO-92
Q202	KSC945	



## FSCQ0965RT Typical Application Circuit (Continued)



Figure 44. Transformer Schematic Diagram

### Winding Specification

No	Pin (s→f)	Wire	Turns	Winding Method
N <sub>p1</sub>	1–3	0.5φ × 1	32	Center Winding
N <sub>125V/2</sub>	16–15	0.5φ × 1	32	Center Winding
N <sub>24V</sub>	18–17	0.4φ × 2	13	Center Winding
N <sub>12V</sub>	12–13	0.5φ × 2	7	Center Winding
N <sub>p2</sub>	3–4	0.5φ × 1	32	Center Winding
N <sub>125V/2</sub>	15–14	0.5φ × 1	32	Center Winding
N <sub>18V</sub>	11–10	0.4φ × 2	10	Center Winding
N <sub>a</sub>	7–6	0.3φ × 1	20	Center Winding

### Electrical Characteristics

	Pin	Specification	Remarks
Inductance	1–3	410 μH ±5%	1 kHz, 1 V
Leakage Inductance	1–3	10 μH Max.	2nd all short

### Core & Bobbin

- Core: EER3540
- Bobbin: EER3540
- Ae: 107 mm<sup>2</sup>

## Bill of Materials

Part	Value	Note
<b>Fuse</b>		
FUSE	250 V / 3 A	
<b>NTC</b>		
RT101	5D-9	
<b>Resistor</b>		
R101	100 k $\Omega$	0.25 W
R102	150 k $\Omega$	0.25 W
R103	5.1 $\Omega$	0.25 W
R104	1.5 k $\Omega$	0.25 W
R105	470 $\Omega$	0.25 W
R106	1.5 k $\Omega$	1 W
R107	Open	
R201	1 k $\Omega$	0.25 W
R202	1 k $\Omega$	0.25 W
R203	39 k $\Omega$	0.25 W
R204	4.7 k $\Omega$	0.25 W, 1%
R205	220 k $\Omega$	0.25 W, 1%
R206	5.1 k $\Omega$	0.25 W
R207	5.1 k $\Omega$	0.25 W
R208	1 k $\Omega$	0.25 W
VR201	30 k $\Omega$	
<b>Capacitor</b>		
C101	330 nF / 275 V <sub>AC</sub>	
C102	220 $\mu$ F / 400 V	Box Capacitor
C103	10 $\mu$ F / 50 V	Electrolytic
C104	10 $\mu$ F / 50 V	Electrolytic
C105	3.9 nF / 50 V	Electrolytic
C106	47 nF / 50 V	Film Capacitor
C107	1 nF / 1 kV	Film Capacitor
C108	Open	
C201	100 $\mu$ F / 160 V	Electrolytic
C202	47 $\mu$ F / 160 V	Electrolytic
C203	1000 $\mu$ F / 35 V	Electrolytic
C204	1000 $\mu$ F / 35 V	Electrolytic
C205	1000 $\mu$ F / 35 V	Electrolytic
C206	22 nF / 50 V	Film Capacitor
C207	470 pF / 1 kV	Ceramic Capacitor
C208	470 pF / 1 kV	Ceramic Capacitor
C209	470 pF / 1 kV	Ceramic Capacitor
C210	470 pF / 1 kV	Ceramic Capacitor
C301	2.2 nF / 1 kV	AC Ceramic Capacitor

Part	Value	Note
<b>Inductor</b>		
BEAD101	BEAD	
BEAD201	5 $\mu$ H	3 A
<b>Diode</b>		
D101	1N4937	1 A, 600 V
D102	1N4937	1 A, 600 V
D103	1N4148	0.15 A, 50 V
D104	Short	
D105	Open	
ZD101	1N4746	18 V, 1 W
ZD102	Open	
ZD201	1N5231	5.1 V, 0.5 W
D201	1N4148	0.15 A, 50 V
D202	EGP30J	3 A, 600 V
D203	EGP30D	3 A, 200 V
D204	EGP20D	2 A, 200 V
D205	EGP20D	2 A, 200 V
<b>Bridge Diode</b>		
BD101	GSIB660	6 A, 600 V
<b>Line Filter</b>		
LF101		14 mH
<b>Transformer</b>		
T101	EER3540	
<b>Switch</b>		
SW201	ON/OFF	For MCU Signal
<b>IC</b>		
IC101	FSCQ0965RT	TO-220F-5L
OPT101	FOD817A	
Q201	KA431LZ	TO-92
Q202	KSC945	

## FSCQ1265RT Typical Application Circuit

Application	Output Power	Input Voltage	Output Voltage (Max. Current)
C-TV	132 W	Universal Input (90–270 V <sub>ac</sub> )	8.5 V (0.5 A)
			15 V (0.5 A)
			140 V (0.6 A)
			24 V (1.5 A)

### Features

- High Efficiency (>83% at 90 V<sub>ac</sub> Input)
- Wider Load Range through the Extended Quasi-Resonant Operation
- Low Standby Mode Power Consumption (<1 W)
- Low Component Count
- Enhanced System Reliability Through Various Protection Functions
- Internal Soft-Start (20 ms)

### Key Design Notes

- 24 V Output Designed to Drop to 8 V in Standby Mode

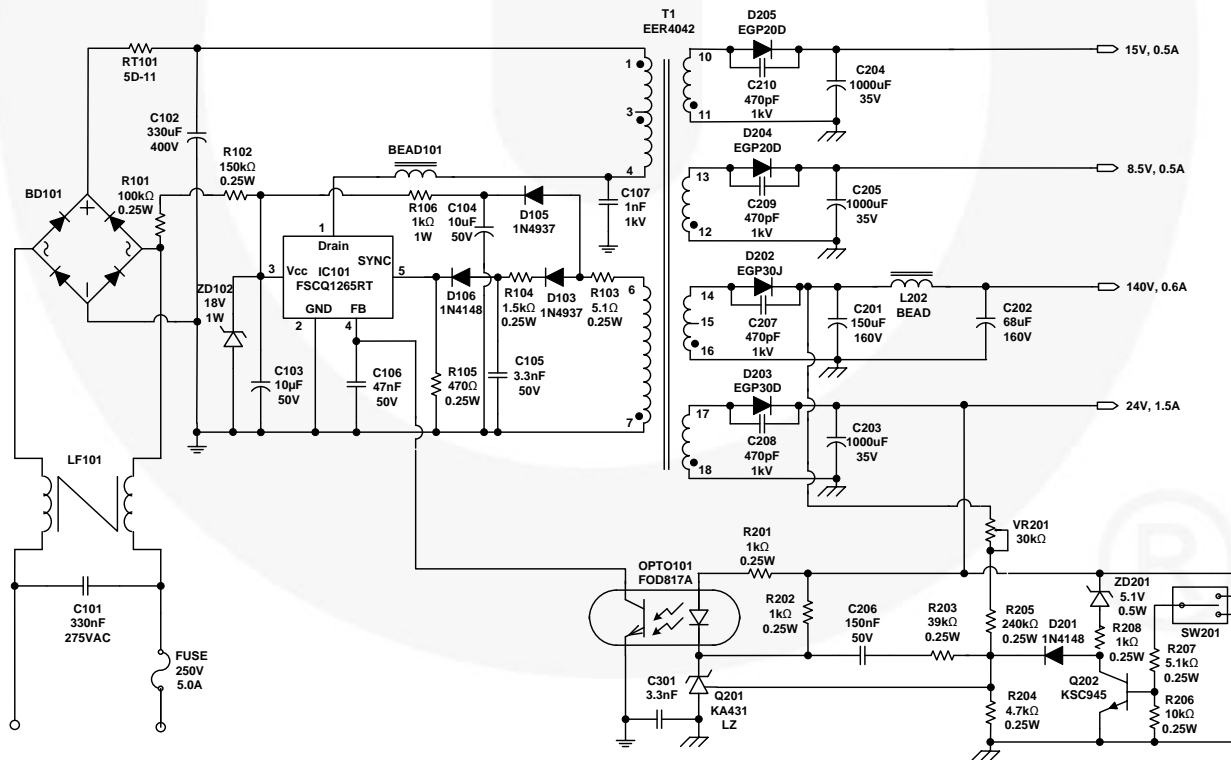

Figure 45. FSCQ1265RT Typical Application Circuit Schematic

## FSCQ1265RT Typical Application Circuit (Continued)

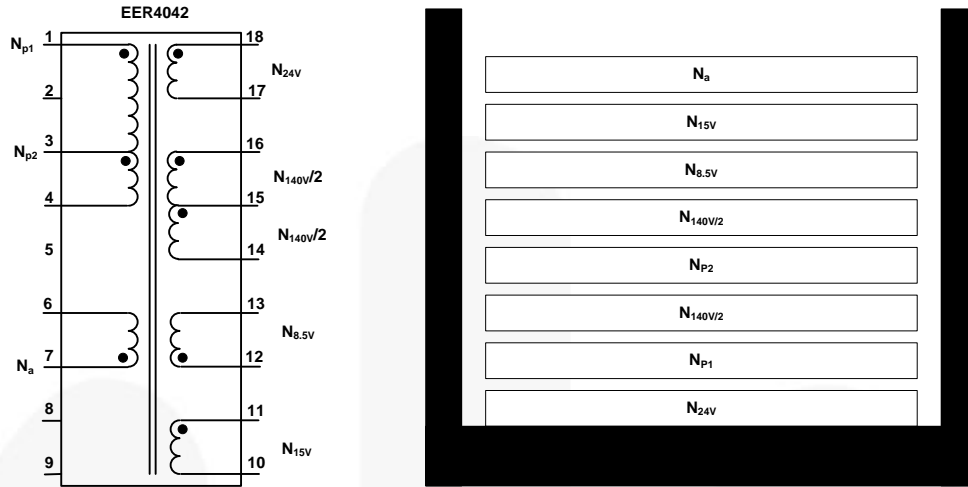

Figure 46. Transformer Schematic Diagram

### Winding Specification

No	Pin (s→f)	Wire	Turns	Winding Method
N <sub>24</sub>	18–17	0.65φ × 2	8	Space Winding
N <sub>P1</sub>	1–3	0.1φ × 10 × 2	20	Center Winding
N <sub>140V/2</sub>	16–15	0.1φ × 10 × 2	23	Center Winding
N <sub>p2</sub>	3–4	0.1φ × 10 × 2	20	Center Winding
N <sub>140V/2</sub>	15–14	0.1φ × 10 × 2	22	Center Winding
N <sub>8.5V</sub>	12–13	0.6φ × 1	3	Space Winding
N <sub>15V</sub>	11–10	0.6φ × 1	6	Space Winding
N <sub>a</sub>	7–6	0.3φ × 1	13	Space Winding

### Electrical Characteristics

	Pin	Specification	Remarks
Inductance	1–4	315 μH ±5%	1 kHz, 1 V
Leakage Inductance	1–4	10 μH Max.	2nd all short

### Core & Bobbin

- Core: EER4042
- Bobbin: EER4042 (18 Pin)
- Ae: 153 mm<sup>2</sup>

## Bill of Materials

Part	Value	Note
<b>Fuse</b>		
FUSE	250 V / 5 A	
<b>NTC</b>		
RT101	5D-11	
<b>Resistor</b>		
R101	100 k $\Omega$	0.25 W
R102	150 k $\Omega$	0.25 W
R103	5.1 $\Omega$	0.25 W
R104	1.5 k $\Omega$	0.25 W
R105	470 $\Omega$	0.25 W
R106	1 k $\Omega$	1 W
R107	Open	
R201	1 k $\Omega$	0.25 W
R202	1 k $\Omega$	0.25 W
R203	39 k $\Omega$	0.25 W
R204	4.7 k $\Omega$	0.25 W, 1%
R205	240 k $\Omega$	0.25 W, 1%
R206	10 k $\Omega$	0.25 W
R207	5.1 k $\Omega$	0.25 W
R208	1 k $\Omega$	0.25 W
VR201	30 k $\Omega$	
<b>Capacitor</b>		
C101	330 nF / 275 V <sub>AC</sub>	
C102	330 $\mu$ F / 400 V	Box Capacitor
C103	10 $\mu$ F / 50 V	Electrolytic
C104	10 $\mu$ F / 50 V	Electrolytic
C105	3.3 nF / 50 V	Electrolytic
C106	47 nF / 50 V	Film Capacitor
C107	1 nF / 1 kV	Film Capacitor
C108	Open	
C201	100 $\mu$ F / 160 V	Electrolytic
C202	68 $\mu$ F / 160 V	Electrolytic
C203	1000 $\mu$ F / 35 V	Electrolytic
C204	1000 $\mu$ F / 35 V	Electrolytic
C205	1000 $\mu$ F / 35 V	Electrolytic
C206	150 nF / 50 V	Film Capacitor
C207	470 pF / 1 kV	Ceramic Capacitor
C208	470 pF / 1 kV	Ceramic Capacitor
C209	470 pF / 1 kV	Ceramic Capacitor
C210	470 pF / 1 kV	Ceramic Capacitor
C301	3.3 nF / 1 kV	AC Ceramic Capacitor

Part	Value	Note
<b>Inductor</b>		
BEAD101	BEAD	
BEAD201	5 $\mu$ H	3 A
<b>Diode</b>		
D101	1N4937	1 A, 600 V
D102	1N4937	1 A, 600 V
D103	1N4148	0.15 A, 50 V
D104	Short	
D105	Open	
ZD101	1N4746	18 V, 1 W
ZD102	Open	
ZD201	1N5231	5.1 V, 0.5 W
D201	1N4148	0.15 A, 50 V
D202	EGP30J	3 A, 600 V
D203	EGP30D	3 A, 200 V
D204	EGP20D	2 A, 200 V
D205	EGP20D	2 A, 200 V
<b>Bridge Diode</b>		
BD101	GSIB660	6 A, 600 V
<b>Line Filter</b>		
LF101		14 mH
<b>Transformer</b>		
T101	EER4042	
<b>Switch</b>		
SW201	ON/OFF	For MCU Signal
<b>IC</b>		
IC101	FSCQ1265RT	TO-220F-5L
OPT101	FOD817A	
Q201	KA431LZ	TO-92
Q202	KSC945	

## FSCQ1565RT Typical Application Circuit

Application	Output Power	Input Voltage	Output Voltage (Max. Current)
C-TV	160 W	Universal Input (90–270 V <sub>ac</sub> )	8.5 V (0.5 A)
			15 V (0.5 A)
			140 V (0.8 A)
			24 V (1.5 A)

### Features

- High Efficiency (>83% at 90 V<sub>ac</sub> Input)
- Wider Load Range through the Extended Quasi-Resonant Operation
- Low Standby Mode Power Consumption (<1 W)
- Low Component Count
- Enhanced System Reliability Through Various Protection Functions
- Internal Soft-Start (20 ms)

### Key Design Notes

- 24 V Output Designed to Drop to 8 V in Standby Mode

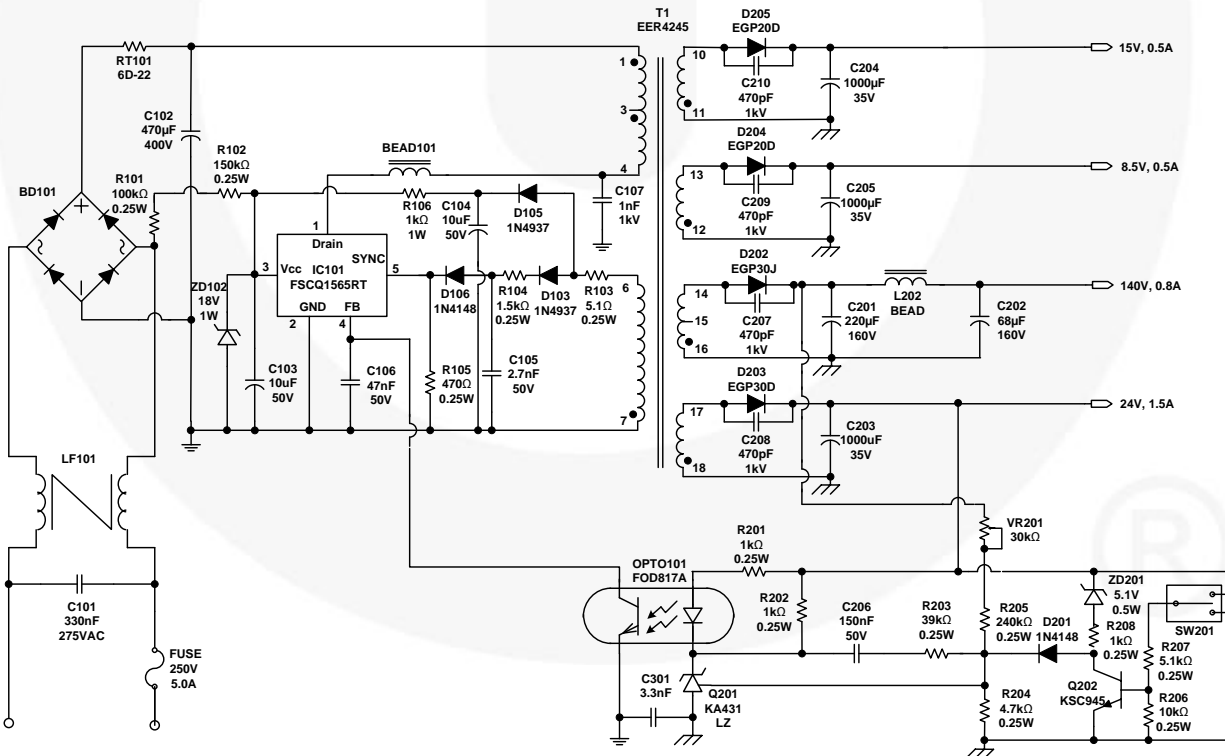

Figure 47. FSCQ1265RT Typical Application Circuit Schematic

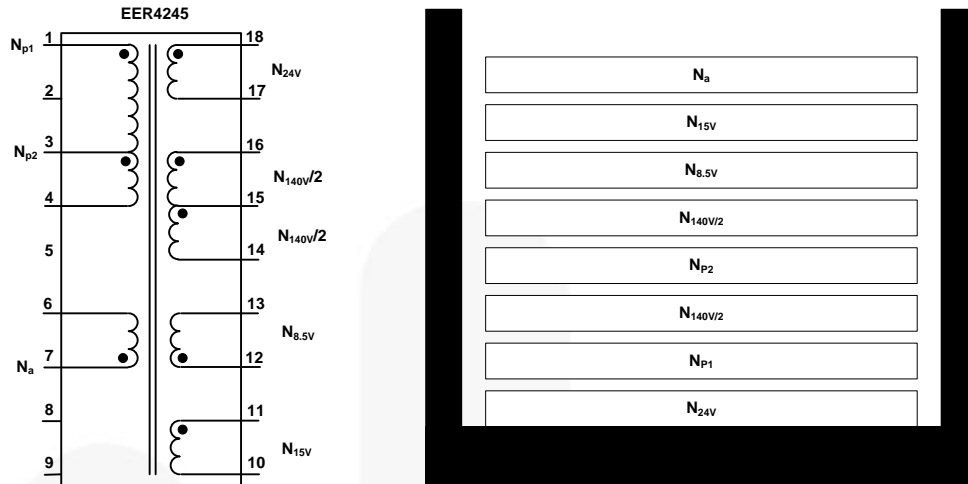

Figure 48. Transformer Schematic Diagram

### Winding Specification

No	Pin (s→f)	Wire	Turns	Winding Method
N <sub>24</sub>	18–17	0.65φ × 2	5	Space Winding
N <sub>P1</sub>	1–3	0.08φ × 20 × 2	13	Center Winding
N <sub>140V/2</sub>	16–15	0.08φ × 20 × 2	15	Center Winding
N <sub>p2</sub>	3–4	0.08φ × 20 × 2	13	Center Winding
N <sub>140V/2</sub>	15–14	0.08φ × 20 × 2	14	Center Winding
N <sub>8.5V</sub>	12–13	0.6φ × 1	2	Space Winding
N <sub>15V</sub>	11–10	0.6φ × 1	3	Space Winding
N <sub>a</sub>	7–6	0.3φ × 1	8	Space Winding

### Electrical Characteristics

	Pin	Specification	Remarks
Inductance	1–4	220 μH ±5%	1 kHz, 1 V
Leakage Inductance	1–4	10 μH Max.	2nd all short

### Core & Bobbin

- Core: EER4245
- Bobbin: EER4245 (18 Pin)
- Ae: 201.8 mm<sup>2</sup>

### Bill of Materials

Part	Value	Note
<b>Fuse</b>		
FUSE	250 V / 5 A	
<b>NTC</b>		
RT101	6D-22	
<b>Resistor</b>		
R101	100 kΩ	0.25 W
R102	150 kΩ	0.25 W
R103	5.1 Ω	0.25 W
R104	1.5 kΩ	0.25 W
R105	470 Ω	0.25 W
R106	1 kΩ	1 W
R107	Open	
R201	1 kΩ	0.25 W
R202	1 kΩ	0.25 W
R203	39 kΩ	0.25 W
R204	4.7 kΩ	0.25 W, 1%
R205	240 kΩ	0.25 W, 1%
R206	10 kΩ	0.25 W
R207	5.1 kΩ	0.25 W
R208	1 kΩ	0.25 W
VR201	30 kΩ	
<b>Capacitor</b>		
C101	330 nF / 275 V <sub>AC</sub>	
C102	470 μF / 400 V	Box Capacitor
C103	10 μF / 50 V	Electrolytic
C104	10 μF / 50 V	Electrolytic
C105	2.7 nF / 50 V	Electrolytic
C106	47 nF / 50 V	Film Capacitor
C107	1 nF / 1 kV	Film Capacitor
C108	Open	
C201	220 μF / 160 V	Electrolytic
C202	68 μF / 160 V	Electrolytic
C203	1000 μF / 35 V	Electrolytic
C204	1000 μF / 35 V	Electrolytic
C205	1000 μF / 35 V	Electrolytic
C206	150 nF / 50 V	Film Capacitor
C207	470 pF / 1 kV	Ceramic Capacitor
C208	470 pF / 1 kV	Ceramic Capacitor
C209	470 pF / 1 kV	Ceramic Capacitor
C210	470 pF / 1 kV	Ceramic Capacitor
C301	3.3 nF / 1 kV	AC Ceramic Capacitor

Part	Value	Note
<b>Inductor</b>		
BEAD101	BEAD	
BEAD201	5 μH	3 A
<b>Diode</b>		
D101	1N4937	1 A, 600 V
D102	1N4937	1 A, 600 V
D103	1N4148	0.15 A, 50 V
D104	Short	
D105	Open	
ZD101	1N4746	18 V, 1 W
ZD102	Open	
ZD201	1N5231	5.1 V, 0.5 W
D201	1N4148	0.15 A, 50 V
D202	EGP30J	3 A, 600 V
D203	EGP30D	3 A, 200 V
D204	EGP20D	2 A, 200 V
D205	EGP20D	2 A, 200 V
<b>Bridge Diode</b>		
BD101	GSIB660	6 A, 600 V
<b>Line Filter</b>		
LF101		14 mH
<b>Transformer</b>		
T101	EER4245	
<b>Switch</b>		
SW201	ON/OFF	For MCU Signal
<b>IC</b>		
IC101	FSCQ1565RT	TO-220F-5L
OPT101	FOD817A	
Q201	KA431LZ	TO-92
Q202	KSC945	

PCB Layout

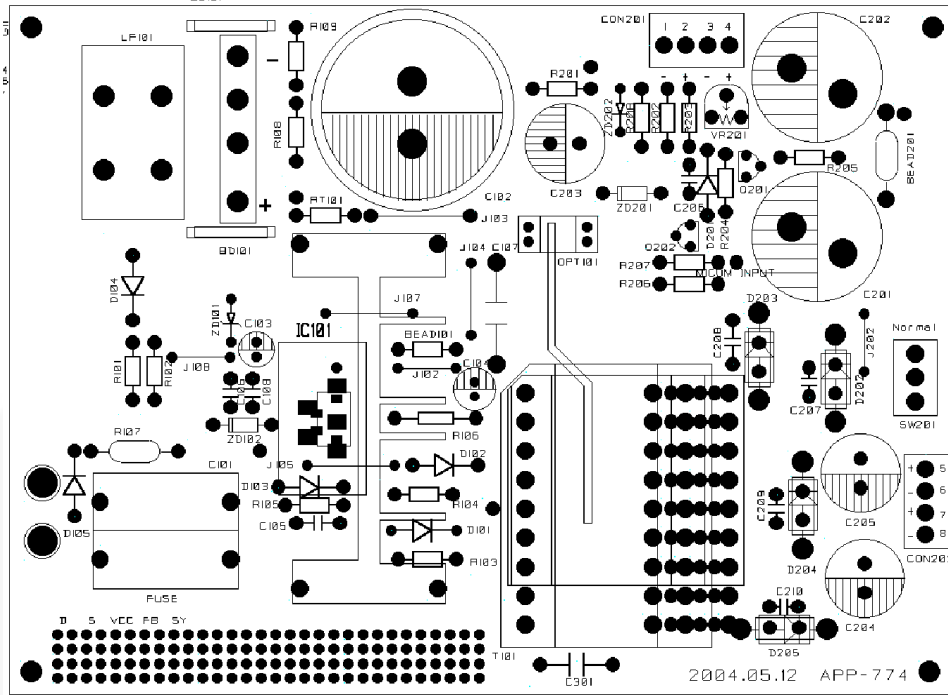

Figure 49. Top View

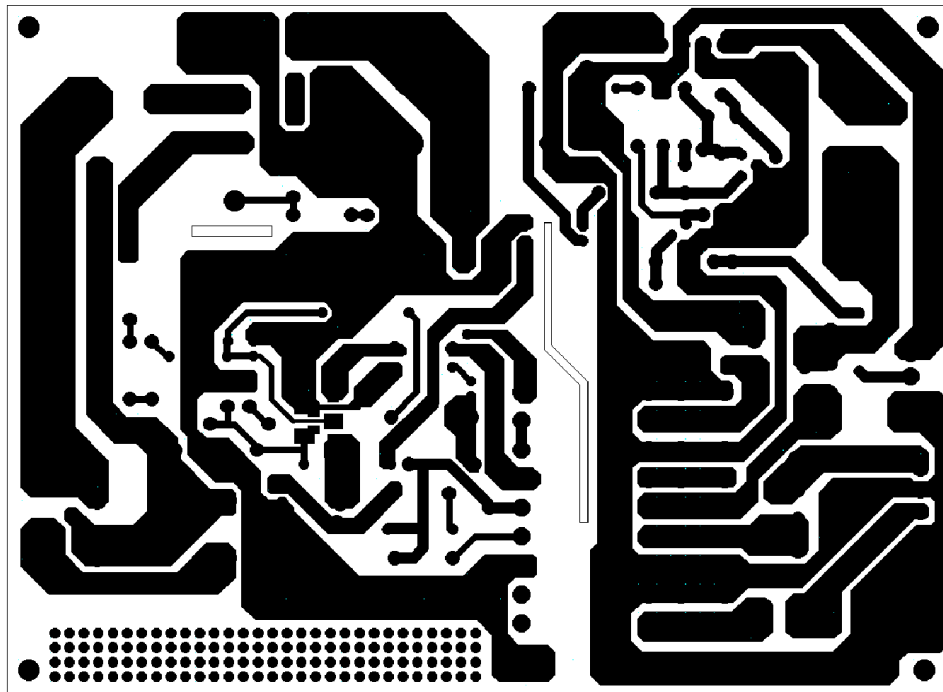
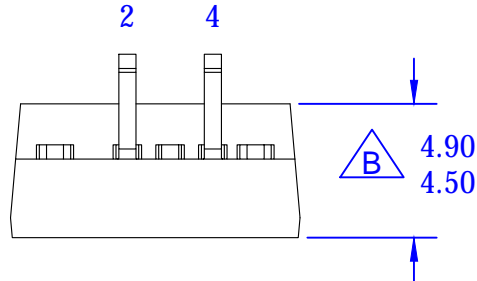
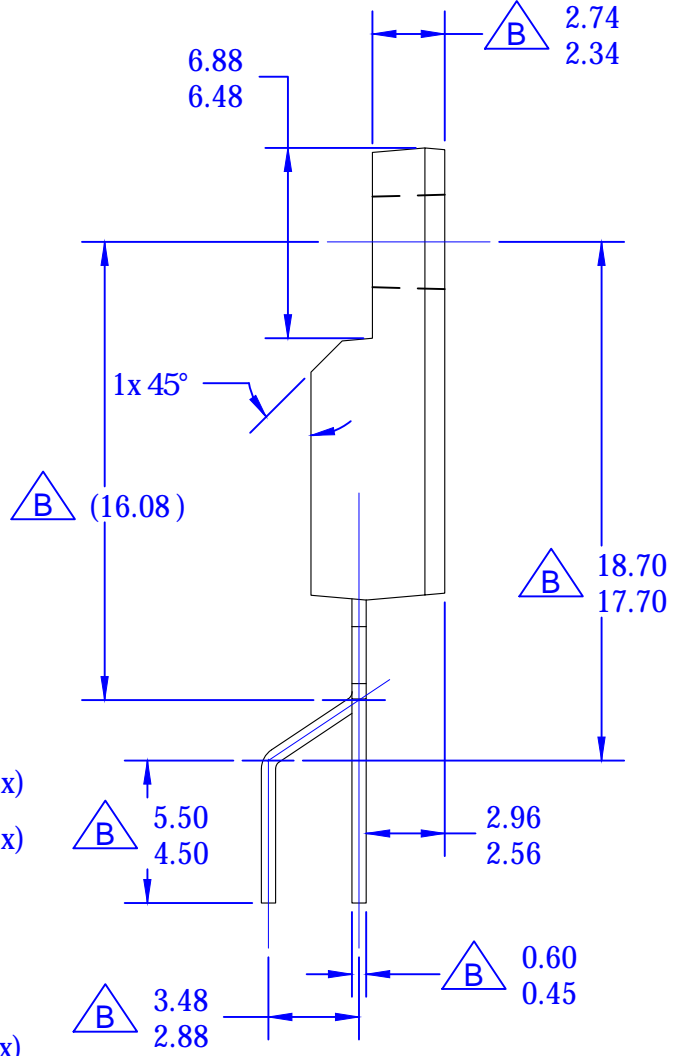
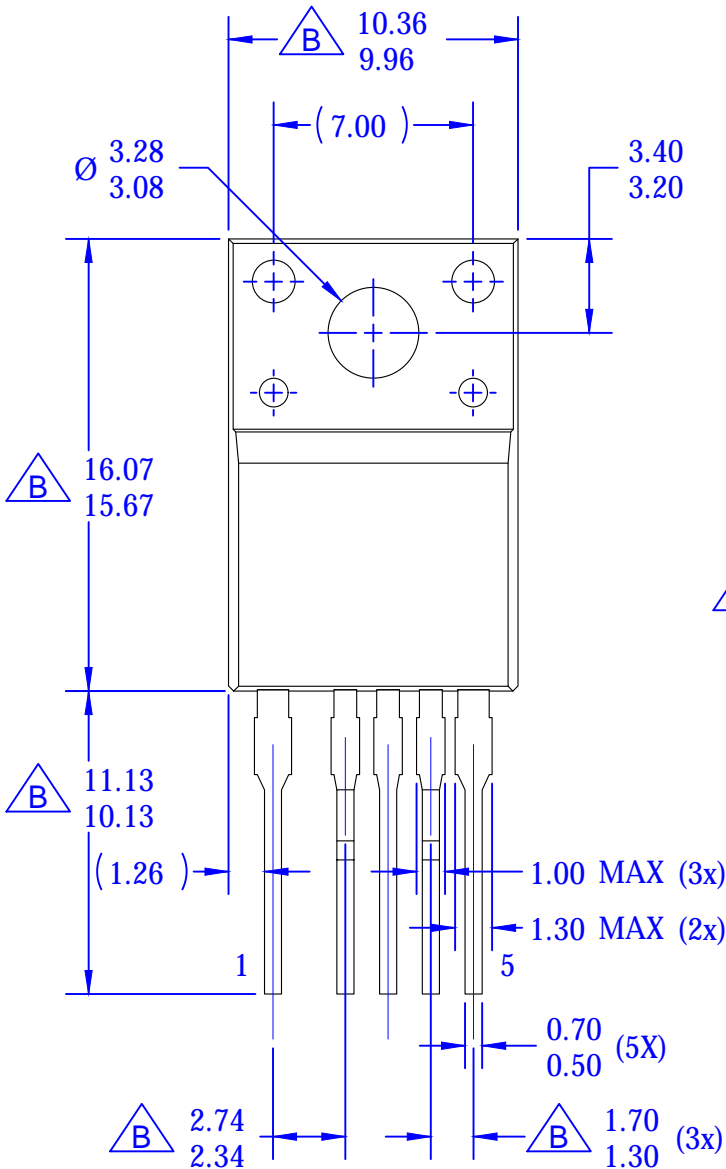



Figure 50. Bottom View



NOTES:

- A. EXCEPT WHERE NOTED CONFORMS TO EIAJ SC91A.
- B**. DOES NOT COMPLY EIAJ STD. VALUE.
- C. ALL DIMENSIONS ARE IN MILLIMETERS.
- D. DIMENSIONS ARE EXCLUSIVE OF BURRS, MOLD FLASH AND TIE BAR PROTRUSIONS.
- E. DIMENSION AND TOLERANCE AS PER ASME Y14.5-1994.
- F. DRAWING FILE NAME: TO220C05REV2



ON Semiconductor and  are trademarks of Semiconductor Components Industries, LLC dba ON Semiconductor or its subsidiaries in the United States and/or other countries. ON Semiconductor owns the rights to a number of patents, trademarks, copyrights, trade secrets, and other intellectual property. A listing of ON Semiconductor's product/patent coverage may be accessed at [www.onsemi.com/site/pdf/Patent-Marking.pdf](http://www.onsemi.com/site/pdf/Patent-Marking.pdf). ON Semiconductor reserves the right to make changes without further notice to any products herein. ON Semiconductor makes no warranty, representation or guarantee regarding the suitability of its products for any particular purpose, nor does ON Semiconductor assume any liability arising out of the application or use of any product or circuit, and specifically disclaims any and all liability, including without limitation special, consequential or incidental damages. Buyer is responsible for its products and applications using ON Semiconductor products, including compliance with all laws, regulations and safety requirements or standards, regardless of any support or applications information provided by ON Semiconductor. "Typical" parameters which may be provided in ON Semiconductor data sheets and/or specifications can and do vary in different applications and actual performance may vary over time. All operating parameters, including "Typicals" must be validated for each customer application by customer's technical experts. ON Semiconductor does not convey any license under its patent rights nor the rights of others. ON Semiconductor products are not designed, intended, or authorized for use as a critical component in life support systems or any FDA Class 3 medical devices or medical devices with a same or similar classification in a foreign jurisdiction or any devices intended for implantation in the human body. Should Buyer purchase or use ON Semiconductor products for any such unintended or unauthorized application, Buyer shall indemnify and hold ON Semiconductor and its officers, employees, subsidiaries, affiliates, and distributors harmless against all claims, costs, damages, and expenses, and reasonable attorney fees arising out of, directly or indirectly, any claim of personal injury or death associated with such unintended or unauthorized use, even if such claim alleges that ON Semiconductor was negligent regarding the design or manufacture of the part. ON Semiconductor is an Equal Opportunity/Affirmative Action Employer. This literature is subject to all applicable copyright laws and is not for resale in any manner.

## PUBLICATION ORDERING INFORMATION

### LITERATURE FULFILLMENT:

Literature Distribution Center for ON Semiconductor  
19521 E. 32nd Pkwy, Aurora, Colorado 80011 USA  
**Phone:** 303-675-2175 or 800-344-3860 Toll Free USA/Canada  
**Fax:** 303-675-2176 or 800-344-3867 Toll Free USA/Canada  
**Email:** [orderlit@onsemi.com](mailto:orderlit@onsemi.com)

**N. American Technical Support:** 800-282-9855 Toll Free  
USA/Canada  
**Europe, Middle East and Africa Technical Support:**  
Phone: 421 33 790 2910  
**Japan Customer Focus Center**  
Phone: 81-3-5817-1050

**ON Semiconductor Website:** [www.onsemi.com](http://www.onsemi.com)  
**Order Literature:** <http://www.onsemi.com/orderlit>  
For additional information, please contact your local  
Sales Representative

# Mouser Electronics

Authorized Distributor

Click to View Pricing, Inventory, Delivery & Lifecycle Information:

[Fairchild Semiconductor:](#)

[FSCQ0565RTYDTU](#)