

BS-1632, BS-1634, BS-1636

2, 4 6

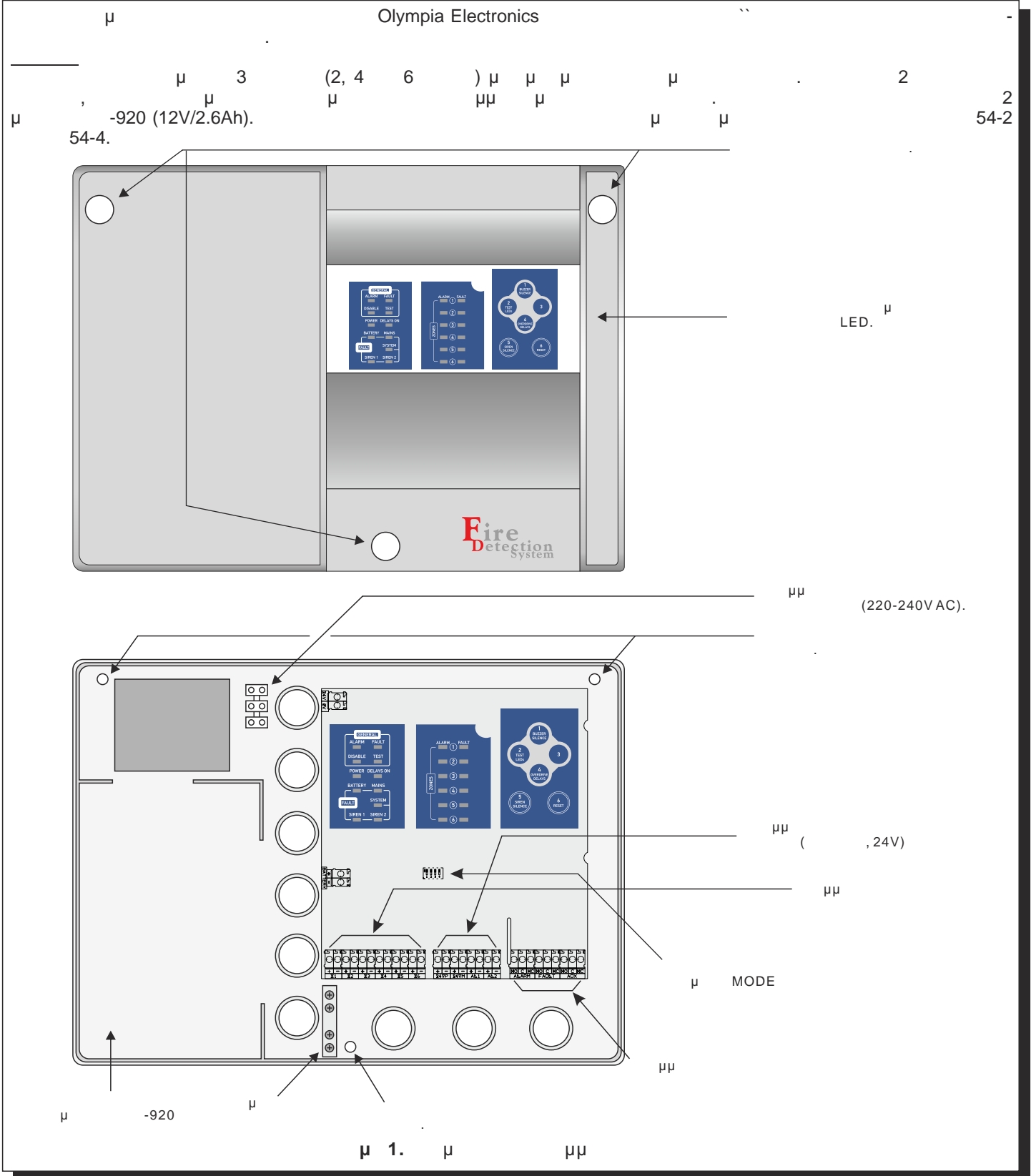

2:

2

"34",

(34)

'4' '4'.

(34)

'5' '5'.

Reset

LED

(34)

'5' '6'.

(34)

'5' '4'.
LED 'Fault'

o LED 'General disable'

1, 2, 3, 4, 5

6

Fault.

RESET

30

'General disable'

led

(34)

'6' '6'.
LED siren 1

LED 'General Test'
siren 2

1 2

LED Fault.

RESET

30

o LED 'General disable'

ON/OFF:

(34)

'6' '4'.

o LED

"Delays ON"
4-6-4.

3-

3:

3

"364",

relay

RELAY

Relay (AUX RELAY).

(364)

'5'.

LED 'General fault'

'General alarm'

Alarm LED
Alarm LED

Fault LED

AUX RELAY.

KAI (

Alarm LED

- cross zone).

AUX

Fault LED

Fault LED

(

AUX

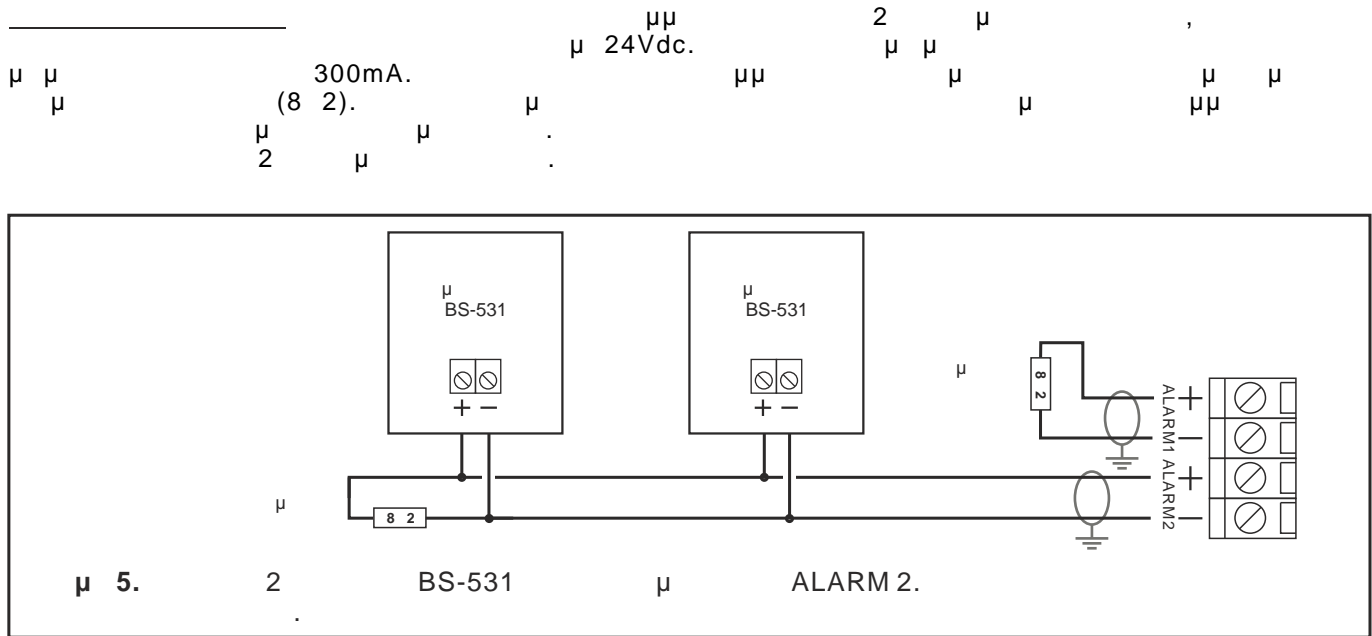

24V_M: 24Vdc reset LED
'General fault'.
24V_P: 24Vdc reset
Relay Alarm :
Relay Fault :
Relay AUX :
: 230V AC. 30VDC 5A

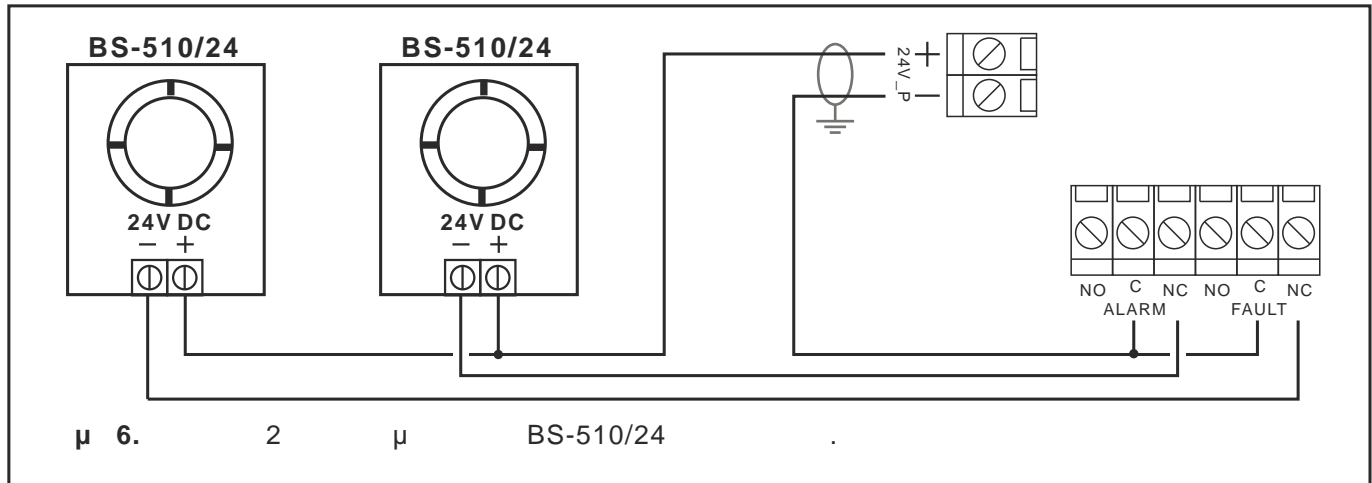

BS-1632, BS-1634 BS-1636

μ
μ CPR:

0848-CPR-002

BS-1636.

BS-1632, 0848-CPR-003

μ CE:

BS-1634

0848-CPR-004

~~olympia electronics~~ 

BS-1632

CONVENTIONAL 2-ZONE
FIRE ALARM PANEL
INSTALL IN ACCORDANCE WITH
PRODUCT MANUAL:
921163600_08_019 (GREEK)
921163600_09_020 (ENGLISH)

POWER SUPPLY:
220-240V AC/50-60Hz



EN 54-2:1997 +A1:2006
EN 54-4:1997 +A1:2002 +A2:2006
0848-CPR-002
DoP No: 921163200_59_003
Provided option:
Output to fire alarm device(s),
delays to outputs
DISCONNECT POWER BEFORE
SERVICING
Production
Date:

KOLINDROS PIERIAS
60061 GREECE

~~olympia electronics~~ 

BS-1634

CONVENTIONAL 4-ZONE
FIRE ALARM PANEL
INSTALL IN ACCORDANCE WITH
PRODUCT MANUAL:
921163600_08_019 (GREEK)
921163600_09_020 (ENGLISH)

POWER SUPPLY:
220-240V AC/50-60Hz



EN 54-2:1997 +A1:2006
EN 54-4:1997 +A1:2002 +A2:2006
0848-CPR-003
DoP No: 921163400_59_003
Provided option:
Output to fire alarm device(s),
delays to outputs
DISCONNECT POWER BEFORE
SERVICING
Production
Date:

KOLINDROS PIERIAS
60061 GREECE

~~olympia electronics~~ 

BS-1636

CONVENTIONAL 6-ZONE
FIRE ALARM PANEL
INSTALL IN ACCORDANCE WITH
PRODUCT MANUAL:
921163600_08_019 (GREEK)
921163600_09_020 (ENGLISH)

POWER SUPPLY:
220-240V AC/50-60Hz



EN 54-2:1997 +A1:2006
EN 54-4:1997 +A1:2002 +A2:2006
0848-CPR-004
DoP No: 921163600_59_003
Provided option:
Output to fire alarm device(s),
delays to outputs
DISCONNECT POWER BEFORE
SERVICING
Production
Date:

KOLINDROS PIERIAS
60061 GREECE

BS-1632, BS-1634, BS-1636

Conventional 2, 4 and 6 zone Fire Alarm Panels



Thank you for purchasing this product of Olympia Electronics. A European manufacturer.

GENERAL

The family of fire detection panels consist of 3 types (2, 4 and 6 zone) with identical operation and indications. The panels have 2 independent siren outputs, Alarm, Fault Relay and a programmable AUX relay. The required batteries for the panels are two A-920 (12V/2.6Ah). All functions and indications are according to European Norms EN 54-2 and EN 54-4.

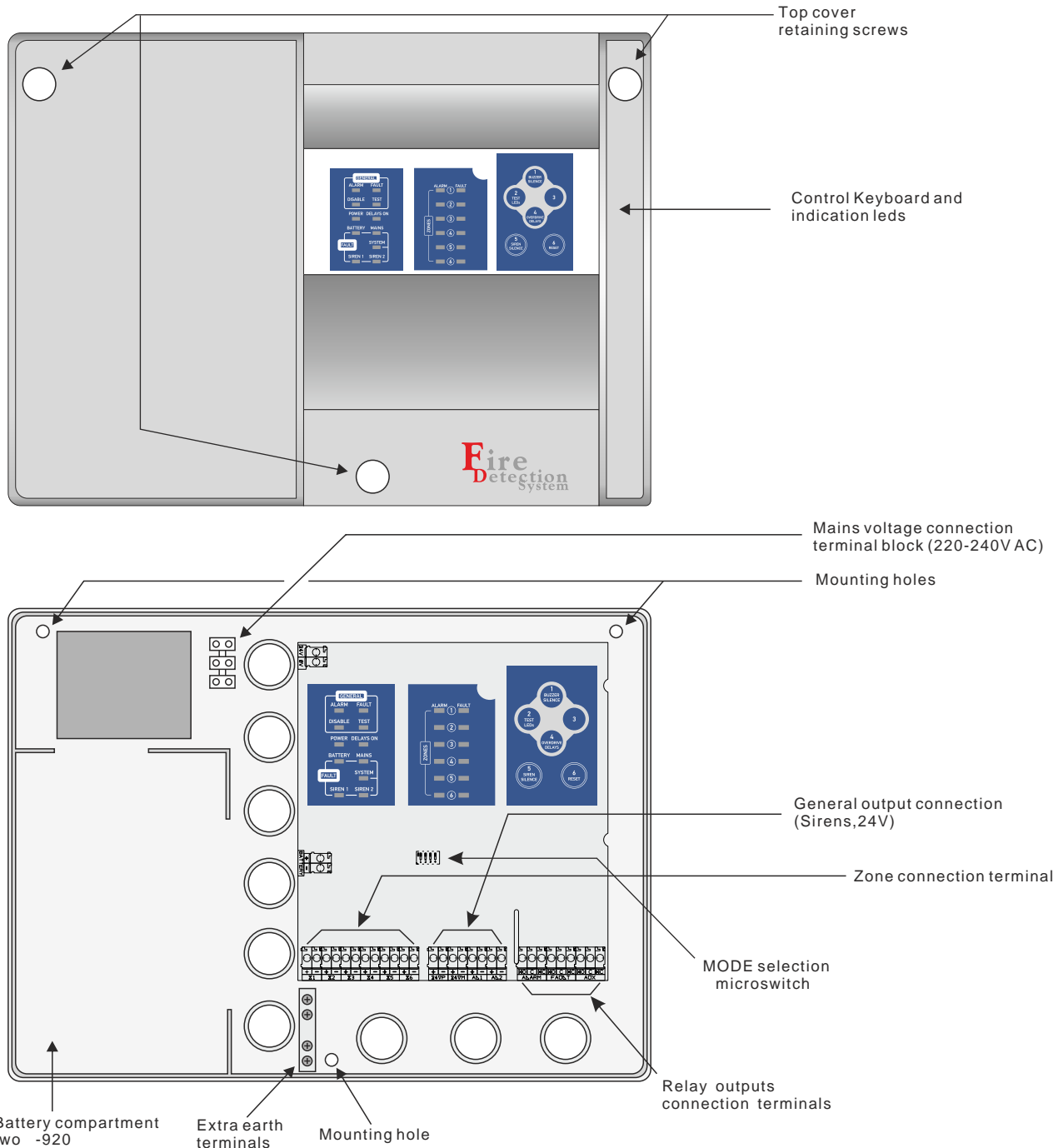

Figure 1. Schematic diagram of the panel

Indication LED description

The schematic shows the control keyboard and the indication plate of a 6 zone BS-1636 panel. Starting from the top left side we can see 4 indicators marked 'General'.

The 'Disable' LED lights in every DISABLE condition.

The 'Test' LED lights in every TEST condition. The panel does not have a test condition as specified in paragraph 11 of EN 54-2.

The 'Fault' LED lights in every FAULT condition. Blinks when we have a FAULT condition and the buzzer is silenced.

The 'Alarm' LED lights when we have an ALARM condition. Blinks when we have an ALARM condition and the buzzer is silenced.

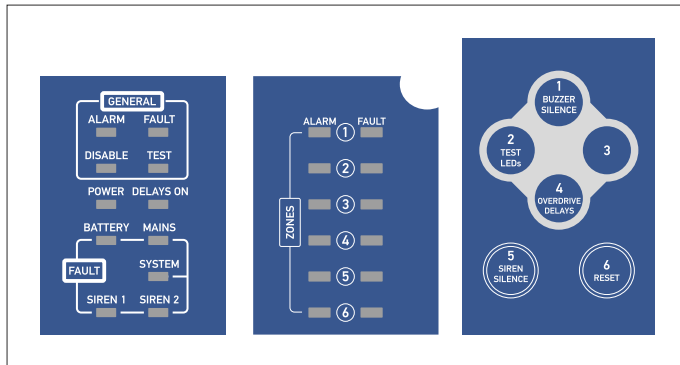

Below is the indicator "POWER" which is on when the panel is working and blinks when there is mains supply failure. On the right of the "POWER" indicator is the "Delays ON" indicator which shows if the delays of the output are enabled or disabled.

Below the 'General' indicator group we can find the indication group called 'Fault'. The 'Battery' LED and 'Mains' LED in combination, show us faults concerning the power supply. These combinations are shown in the panel below.

	Lack of AC voltage	Battery Overcharging	Battery Discharged	Battery Absent	Charger Error	Bad Battery
MAINS Fault	Lights	Lights	Lights	Blinks	Blinks	----
BATTERY Fault	----	Lights	Blinks	Lights	Blinks	Lights

The 'System LED lights to indicate a problem with the main processor unit (System fault).

The LEDs marked 'Siren1' and 'Siren2' correspond to the siren outputs. If a siren out has a short circuit or open circuit then the corresponding LED will blink. If a siren is disabled the corresponding LED will light.

The next group of indicators is the 'Alarm' indication LEDs.

These indicators light when a corresponding zone issues an ALARM condition. Next to this group we have the 'Fault/Disable' indication for each zone. When the panel monitors an open or short circuit condition in a zone then the corresponding LED will blink. If a zone is disabled the corresponding LED will light.

Control keyboard description/operation

The panel is controlled/ operated using the six numeric keys (1 to 6) found on the front panel. When a key is pressed a short tone is issued.

The panel has three access levels.

Access level 1:

has all the functions that can be done directly from the user without using a code. These operations are:

Buzzer silence / Buzzer reactivation: If an alarm or fault condition is issued then the internal buzzer will sound. Pressing the key "1" will silence the buzzer. (The buzzer sounds periodically once every minute.) Pressing this key again will reactivate the buzzer.

Lamp test: Pressing the key "2" a lamp test is conducted by lighting the LEDs. The panel then returns to normal operation. The above tests can be conducted only if the panel is in quiescent state (No fault or alarm conditions).

Override Delays: If an alarm occurs and the delays are active the user can override the delays by pressing the key "4". The output will be immediately activated.

Access level 2:

Includes all the functions that the user can do and an access code is required. The code is "34", it is the same for all panels and can not be changed. The functions that can be implemented using this code are the following:

Evacuate: Gives evacuate signal to the panel.

The user must enter the user code (34) and then the keys '4' and '4'. Then the panel will go to alarm state. The sirens will sound and the internal buzzer also.

Siren Silence: When an alarm is issued and we want to silence the sirens then we must enter the user code (34) and then the keys '5' and '5'. The sirens are silenced but the internal buzzer continues to sound. The panel remains in normal operation. A new alarm from another zone will resound the sirens. To resound the sirens press again the same code.

Panel Reset: When an alarm or fault condition has occurred and we want to reset the panel we must enter the user code (34) and then the keys '5' and '6'. The panel lights all LEDs in sequence and then enters normal operation.

Zone enable/disable: If we want to disable the operation of specific zones then we must enter the user code (34) and then the keys number '5' and '4'. The LED marked 'General disable' start to blink, and if a zone is disabled the corresponding 'Fault' LED lights to indicate this. Using the keys 1, 2, 3, 4, 5 and 6 we can enable or disable the respective zones. The disabled zones light the corresponding LED. The panel exits this mode if no key is pressed for more than 30 seconds. The panel then conducts an automatic RESET and enters normal operation mode. Disabled zones does not give alarm or fault condition. If we have disabled zones then this is indicated with the indicators 'General disable' and the corresponding Disable LED zone and the buzzer sounds once every minute.

Siren enable/disable: If we want to disable the operation of specific sirens we must enter the code (34) and then the keys '6' and '6'. The LED marked 'General Test' start to blink, and if a siren is disabled Siren1 LED lights for siren 1 and Siren2 LED lights for the siren 2. Using the keys 1 and 2 we can enable or disable the respective sirens. The disabled sirens have a LED lighted. The panel exits this mode if no key is pressed for more than 30 seconds. The panel then conducts an automatic RESET and enters normal operation mode. All disabled sirens are supplied with the proper voltage but the panel can not enable them or read their condition. If we have disabled sirens then this is indicated with the indicator 'General disable' and the buzzer sounds once every minute.

Delays ON/OFF: If we want to disable the delays of the outputs. We must enter the code (34) and then the keys '6' and '4'. Then the delays will be disable, the LED marked "Delays ON" will turn off. To enable the delays we must press again the code.

Access level 3:

These functions are implemented during the installation and need the technical code to be accessed. The technical code is "364", it is the same for all panels and can not be changed. These functions can be implemented using the technical code are activation methods used for the relays and can be done only if the panel has not issued an alarm or fault condition. These functions are ancillary and not required by the EN 54-2. These methods of programming are:

AUX RELAY programming: If we want to program the operation behaviour of the AUX RELAY we must enter the technical code (364) and then press the key '5'. The 'General fault' and 'General alarm' LEDs start to blink. The Alarm zone LEDs and the fault LED zone show the way the AUX RELAY. If the Alarm led of the zone is on then we have logic AND for the aux relay activation. If the fault led of the zone is on then we have logic OR for the aux activation.

For example if Alarm Zone 1 and 2 is on and Fault Zone 3 and 4 is on, then the relay will be activated when Z1 and Z2 is in alarm condition or Z3 or Z4 are in alarm condition

To change the state of each zone, press the corresponding number each time.

In order to exit this programming mode and to store the settings in memory do not press any key for more than 30 seconds. This system will conduct an automatic RESET and will enter normal operation mode.

Program Siren delay. If we want to program the delay of the sirens we must enter the technical code (**364**) and then press the key '**4**'. The 'General fault', 'General Disable' and 'General alarm' LEDs start to blink. The Alarm, the Fault/Disable LED of zone 1 and Fault/Disable LED of zone 2 show the programmed delay of the sirens according to the table below. By pressing the key '**1**' you can change the configuration.

	Zero Delay	Delay 1min	Delay 2min	Delay 3min	Delay 4min	Delay 5min
Alarm zone 1	LED ON	LED Blink	LED Off	LED Off	LED Off	LED Off
Fault zone 1	LED Off	LED Off	LED On	LED Blink	LED Off	LED Off
Fault zone 2	LED Off	LED Off	LED Off	LED Off	LED On	LED Blink

RESOUND sirens: It is possible to configure to automatically resound the sirens following an alarm in another zone. You must enter the technical code (**364**) and then press the key '**4**'.

The 'General fault', 'General Disable' and 'General alarm' LEDs start to blink. The Alarm LED of zone 2 led is off the sirens resound following an alarm in another zone else if the led is on the sirens does not resound. By pressing the key '**5**' you can change the configuration.

Programming the delay of general relay (AUX RELAY). If you want to program the delay of the AUX RELAY must enter the technical code (364) and then press '6'. The LED " General fault ", " General Alarm " and " DELAYS ON " begin to blink . The indicative Zone " Alarm " and " Fault LED " indicates delay activation of " AUX RELAY " .

	Without Delay	30 second Delay	60 second Delay	90 Second Delay
Alarm zone 1	LED ON	LED OFF	LED OFF	LED OFF
Fault zone 1	LED OFF	LED ON	LED OFF	LED OFF
Alarm zone 2	LED OFF	LED OFF	LED ON	LED OFF
Fault zone 2	LED OFF	LED OFF	LED OFF	LED ON

To change the mode press ' 1 ' 2' , ' 3' and '4'. To exit the programming mode and store the settings in memory , press the button <5 > . The system will automatically RESET and will enter normal operation.

Below is a table that summarizes all the code and corresponding functions.

Code	Function
3-4-4-4	Evacuate
3-4-5-4	Enable/Disable Zones
3-4-5-5	Silence/Resound Sirens
3-4-5-6	Reset
3-4-6-4	Delays ON/OFF
3-4-6-6	Enable/Disable Sirens
3-6-4-5	Program AUX relay
3-6-4-4	Resound and Delay sirens
3-6-4-6	Program Predelay of AUX Relay

Connections

The three panels of the family have the same connections. The main differences in these panels is the number of the available zones and the number of the relays zones. The common outputs, the maximum consumption and the operation procedures are identical for all the panels.

Connecting detectors and break-glass call points to zones.

By default each zone terminal block has a preinstalled terminal resistor (8 2). This resistor must be removed and installed on the last device of the zone or is left connected on the zone terminals if the zone is not used. The connections to all the zones are identical. What is shown in figures 2, 3 and 4 for zone 1 is valid for all the zones.

The total number of connected devices per zone is 20.

All cable zones must be insulated, to earth ground, to meet EMC requirements.

The cable length for each zone must not exceed the 1.5 kilometres with a cross section cable of 1.5mm².

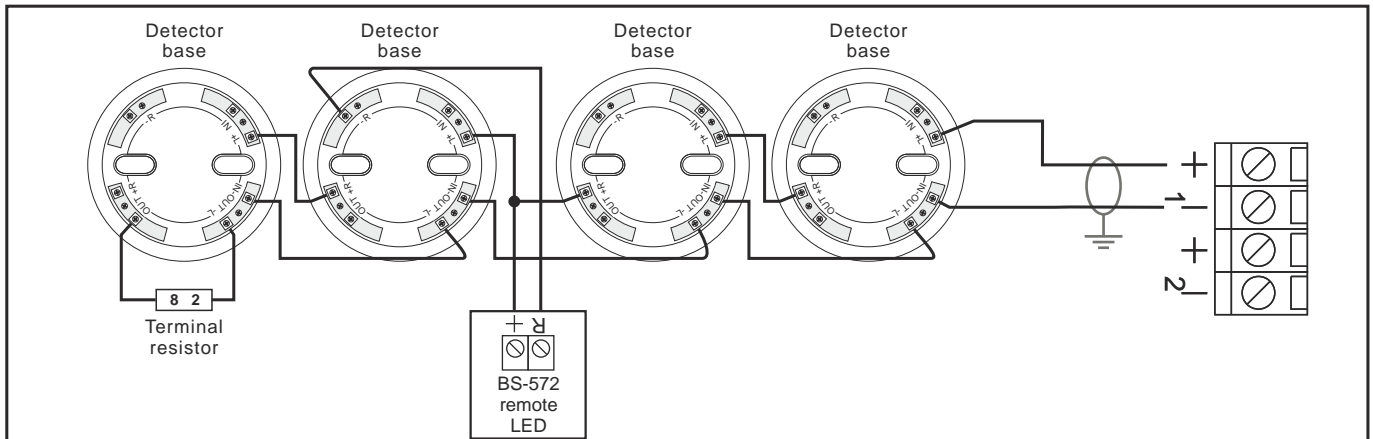

Figure 2. Connecting 4 detector bases to zone 1. Each base can accept BS-655, BS-660 or BS-657 detectors. A remote indication LED BS-572 is connected to one of the detectors.

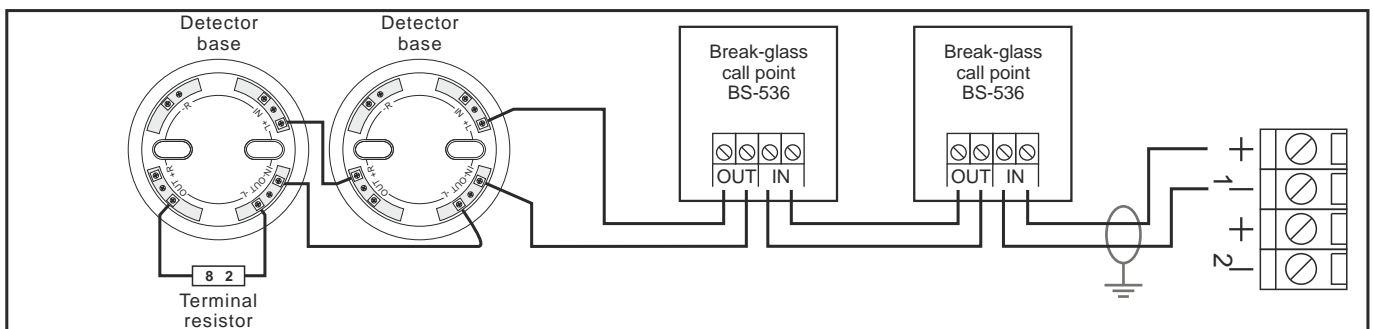

Figure 3. Connecting 2 call points BS-536 and 2 detector bases to the same zone.

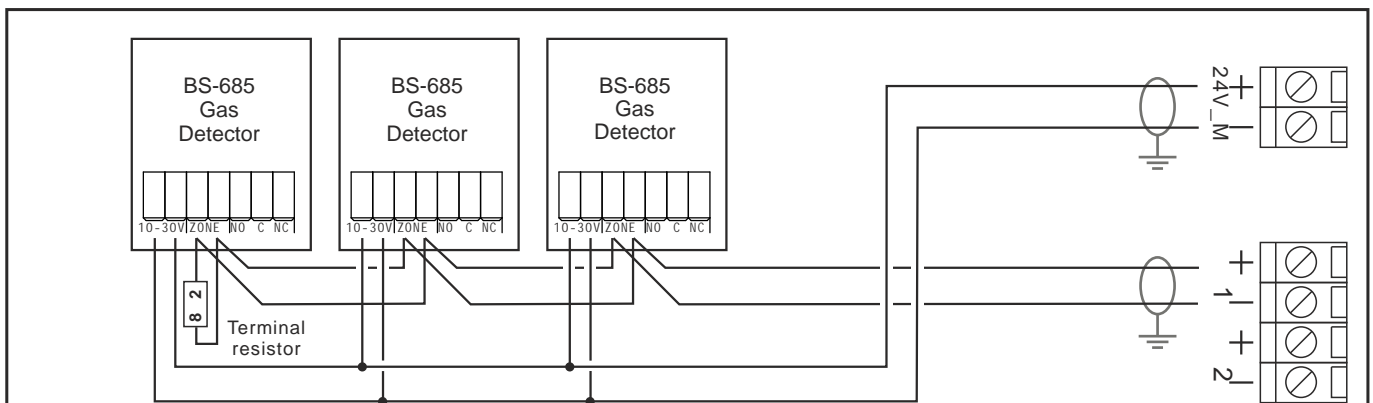

Figure 4. Connecting 3 Gas detectors BS-685 or BS-686. Besides the connections to the zone terminals these detectors must also be connected to the terminals 24V_M in order to be supplied with power.

Siren - Sounder Connections

Each panel offers 2 independent circuits for connecting sirens, bells or other devices that need 24VDC in order to operate. Each circuit can supply a maximum of **300mA**. Each terminal block by default has a pre-installed terminal resistor (8 Ω). This terminal resistor is either removed and installed on the last siren of the line or is left on the terminal block if the circuit is not used.

The connections of both circuits are identical.

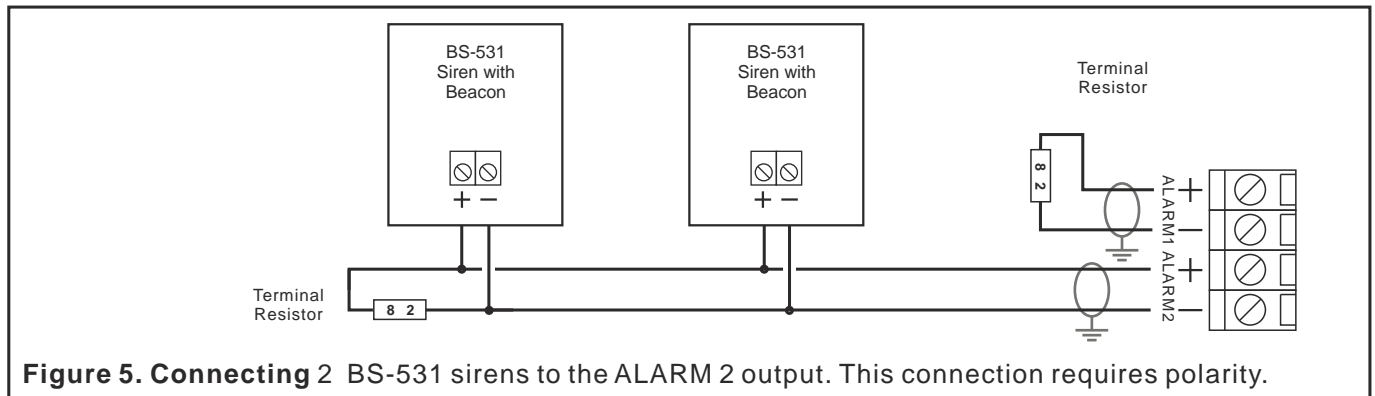

Figure 5. Connecting 2 BS-531 sirens to the ALARM 2 output. This connection requires polarity.

Besides the terminals that were described up to now the panel also has the following outputs :

24V_M: A 24VDC output that is interrupted in the event of a panel reset. It is mainly used for powering gas detectors or other devices that need an interrupted power supply when the panel is resetting. If this output is short circuited then the LED marked 'General fault' is lighted.

24V_P: A 24VDC power output that is not interrupted in the event of a reset. It can be used to power electromagnetic door latches.

Relay Alarm : Voltage free relay contacts are activated when there is an alarm condition.

Relay Fault : Voltage free relay contacts are deactivated when there is an alarm condition.

Relay AUX : Voltage free relay contacts that by default when one zone is in alarm condition.

ATTENTION: The relays are rated at 30VDC and 5A maximum. No 230VAC signals can be connected to these relays.

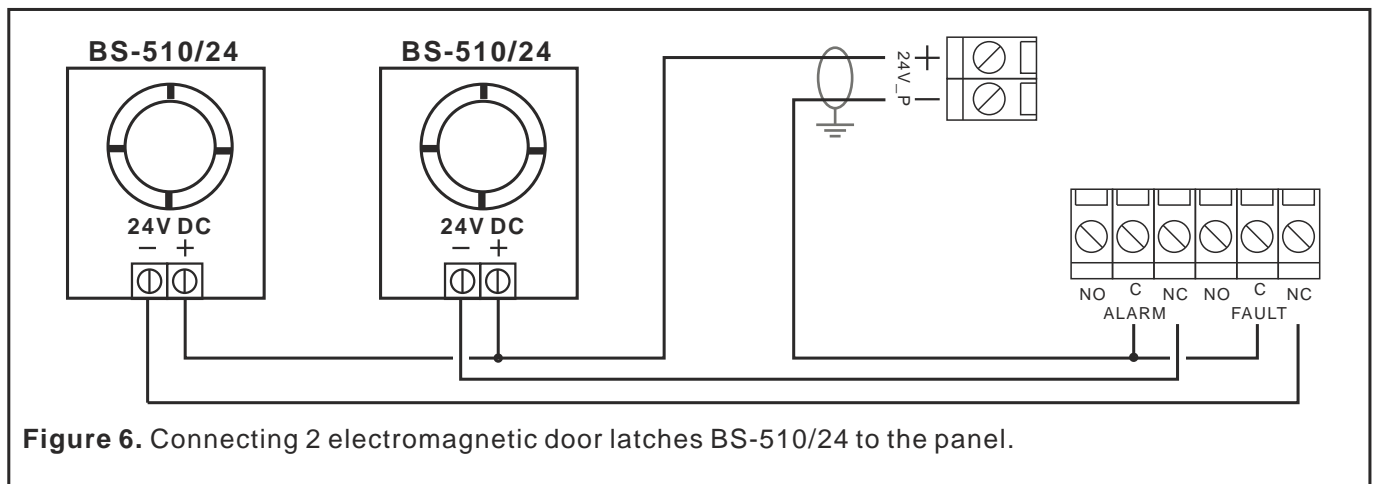

Figure 6. Connecting 2 electromagnetic door latches BS-510/24 to the panel.

Connecting the BS-489 telephone operator

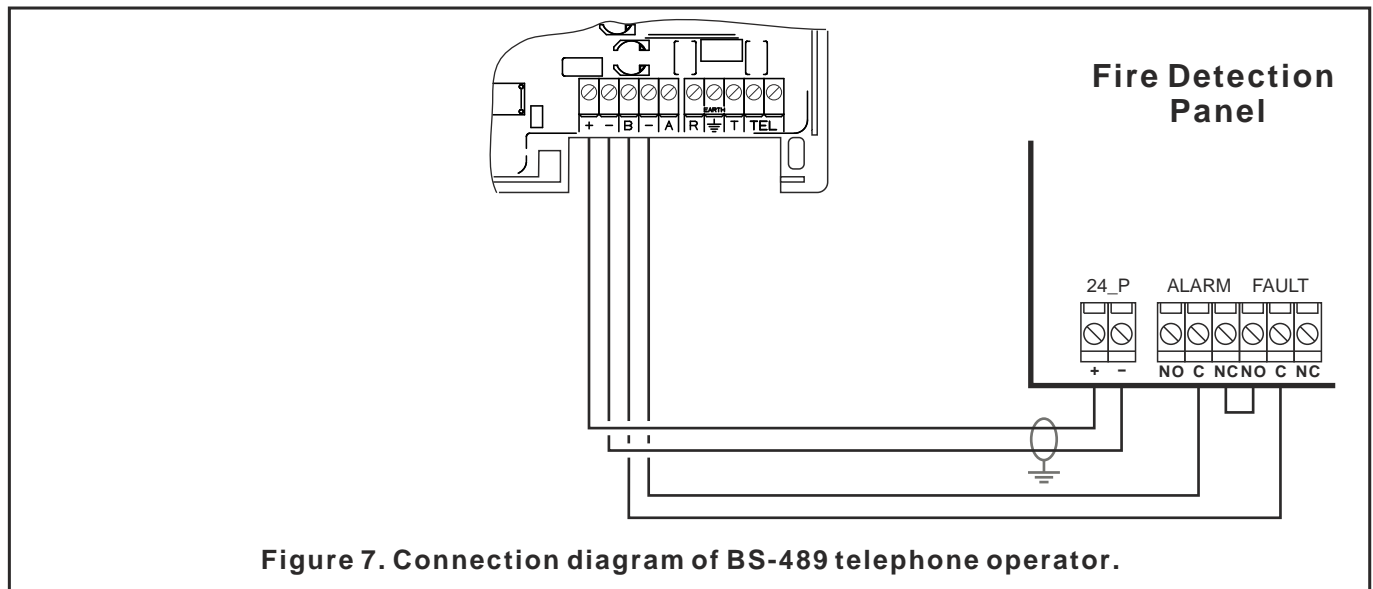

Figure 7. Connection diagram of BS-489 telephone operator.

Installation

The installation of the panel must be carried out by qualified personnel only.

Disconnect power before servicing.

Never insert or remove boards or components with the power on.

During installation use grounded antistatic wrist band to protect this equipment from ESD.

The panel must be installed permanently. It is not allowed to connect the device directly to any socket-outlet.

Mounting the panel to the wall

The site chosen for the location of the panel should be clean and dry and not subject to shock or vibration.

In page 1 shows the mounting holes of the panel.

The panel must be placed above 1m from the floor and 1m below the ceiling and must have distance 30cm from any other devices. No other power lines must pass behind the panel, only the supply cables of the panel.

Cabling

In order to meet EMC requirements, connections of peripherals to the panel must be done using shielded cables.

Each screen or shield braid must properly be connected to the earth terminal block provided, thus ensuring the shortest possible path.

The maximum conductor diameter size, which can be used, is 2,5mm²

Connecting the mains power supply(220-240V AC)

The panel has holes on the back side for all the wiring to pass through. You can connect cables with max. conductor diameter of 2.5mm to the panels terminal blocks.

The mains power supply wiring must use a double insulation cable.

The main supply must include an earth conductor connected to the fixed installation earthing system of the building.

The connection with the mains power supply must be done to the terminal blocks located on the panels up left area Figure 8.

Battery connection

*The battery compartment has the appropriate dimensions for -920 batteries of **Olympia Electronics**.*

The charging unit on PCB is also calculated for the specific batteries.

Replace them only with batteries of the same type.

From the PCB, are connected two battery wires with a special terminal on the edge. They must be connected to the two battery poles. Connect the black wire to the negative pole (marked (-) or a black mark), the red wire to positive pole (marked (+) or a red mark) and connect the included wire for the link as showed in the side figure.

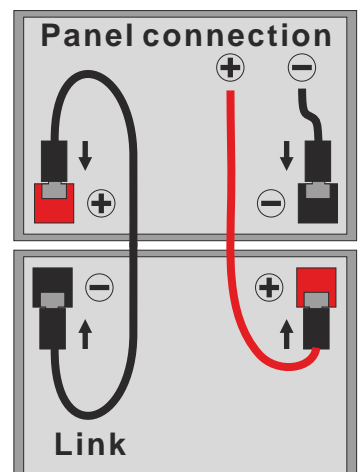

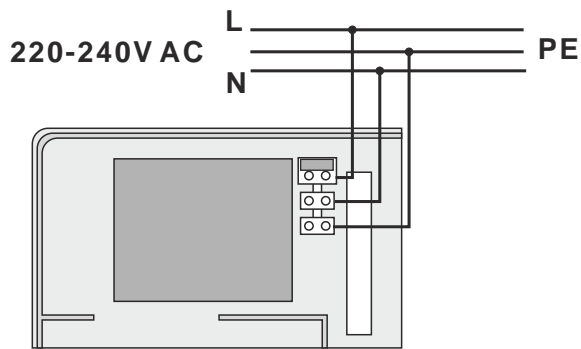

Figure 8. Panels connection with 220-240V AC.

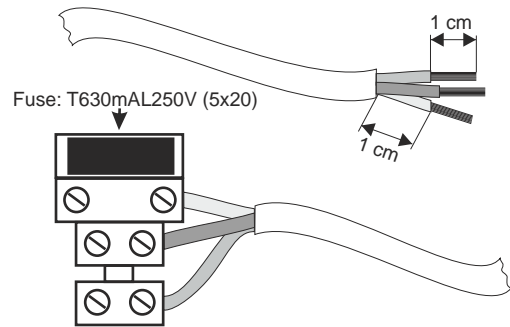

Figure 9. Panels connection with 220-240V AC

Battery disposal .

It is not allowed to discard batteries into common trash bins, they must be discarded only in battery recycling points.

Warnings.

1. Service and maintenance activities should be done only when the device is disconnected from the mains power supply and the battery.
2. During the installation the connections to the mains power supply and the battery must be done after all other connections are finished.
3. The panel connection with the mains supply must be done via a 10A external fuse or an automatic circuit breaker rated at 10A. This fuse has to be a separate, labeled fuse.
4. Always use cables with double insulation.
5. The diameter of the cable must be at least 1mm. (Figure 9)
6. The inner insulation of each cable must not be cut more than 1cm (Figure 9)
7. The outer insulation must not be cut more than 1cm away from the internal insulation.
8. The panel's internal fuse is T630mAL250V with 5x20 dimensions.
9. The battery fuse is a resettable fuse 900mA inside the panel.

Initial Installation

When the connections to zones, sirens and other required outputs are finished then we must connect the mains power supply. In order to aid the installer during the initial installation, the panel offers a special configuration. This configuration is entered by setting MODE switch 1 to the ON position. After entering this mode the panel conducts an auto reset and the 'Power', 'Zone disable' and 'General disable' LEDs blink. The special functions that aid in working out various problems that might arise are:

When a zone has an open circuit then the internal buzzer sounds and the corresponding LED lights. If the problem is corrected then the buzzer is deactivated and the LED is turned off.

When a zone has a short circuit then the internal buzzer sounds and the corresponding LED blinks. If the problem is corrected then the buzzer is deactivated and the LED is turned off.

When a siren output has an open circuit then the internal buzzer is activated and the corresponding fault LED lights. If the problem is corrected then the buzzer is deactivated and the LED is turned off.

When a siren output has a short circuit then the internal buzzer sounds and the corresponding LED blinks. If the problem is corrected then the buzzer is deactivated and the LED is turned off.

When a battery fault exists then the 'Batt fault' LED lights and the 'Power fault' LED blinks. If the problem is corrected then the LEDs are deactivated.

If all the problems are corrected and the installation is operating normally then the MODE switch 1 must be placed in the OFF position. The panel conducts an auto-reset and is ready for operation.

Walk-Testing

By using a special operation mode we can conduct a walk test of the system. To enter walk-test mode set the MODE switch 1 to the ON position. The 'Power', 'Zone disable' and 'General disable' LEDs blink. If an alarm is manually given by either activating a BS-536 call point or by activating a smoke detector with smoke or simulated smoke particles the corresponding Alarm LED of the zone will light and the siren will sound for 2 seconds. Using this method we can test the operation of the zones.

After finishing the walk test set the MODE switch 1 to the OFF position. The panel conducts an automatic reset and enters normal operation mode.

Optional Function of EN 54-2.

The optional function which is provided by the panel is the fire alarm devices paragraph 7.8 of EN 54-2 and delays to outputs (paragraph 7.11 of EN 54-2).

Design

Components of the panels have been selected for the intended purpose, and are expected to operate within their specification when the environmental conditions outside the cabinet of the panel comply with class 3k5 of EN 60721-3-3:1995.

Technical Specifications

	BS-1632 2 zone fire detection panel	BS-1634 4 zone fire detection panel	BS-1636 6 zone fire detection panel
Mains power supply	220-240VAC 50/60Hz		
Consumption	50VA		
Battery type	Two 12V Lead acid sealed 2.6Ah		
Charging circuit	Stabilized power supply 27.6V / max. 400mA		
Zone circuits	2 circuits monitored for short and open circuit conditions (maximum current 35mA)	4 circuits monitored for short and open circuit conditions (maximum current 35mA)	6 circuits monitored for short and open circuit conditions (maximum current 35mA)
Alarm circuits	Two 24V circuits that are monitored for open and short circuit conditions (maximum current 300mA each). Each output is protected with a self-resetting electronic fuse.		
Output 24P	24VDC (± 3 VDC) permanent output with maximum current output 0.3 A The output is protected with a self-resetting electronic fuse.		
Output 24M	24VDC (± 3 VDC) reset interrupted output with maximum current output 0.3 A The output is protected with a self-resetting electronic fuse.		
Outputs Relays	Three relays contacts are rated at 30VDC and 5A maximum each. Under no circumstances should voltages or currents outside limits be connected. All relays output must be protected with a fuse of the same rating.		
Total load	The total output current (zones circuits, siren circuit, outputs 24P, 24M) must not exceed 600mA. (ImaxA = ImaxB = 600mA, Imin = 30mA)		
Autonomy	72 hours (Maximum connected detectors 72 and no load at output 24VM and 24VP)		
Battery cut of voltage	21V		
Maximum current batteries discharge	900mA		
Battery maximum internal resistance Rimax	10hm		
IP	IP 30		
Cables	Cables for fire rated cables systems such a FIP200, MICC, PYROFIL		
Fuse ratings	The panel has only one serviceable fuse to protect incoming mains supply. This fuse is T630mAL250V must be replaced with a fuse of the same type and rating		
Operation temperature	0 to 50 °C		
Humidity	Up to 95% relative humidity		
Construction material	ABS - polycarbonate		
Dimensions	325 x 240 x 85 mm		
Weight	1345gr (3065gr with battery)	1350gr (3070gr with battery)	1360gr (3080gr with battery)
Produced in accordance to	54-2, 54-4		
Guarantee	2 years		

Certification

The panels BS-1632, BS-1634 and BS-1636 are certified from HEEQAC. Also HEEQAC controls the production under CPR number: 0848-CPR-002 for the panel BS-1632, 0848-CPR-003 for the panel BS-1634 and 0848-CPR-004 for the panel BS-1636. Below are the markings:

~~olympia electronics~~ 

BS-1632

CONVENTIONAL 2-ZONE
FIRE ALARM PANEL
INSTALL IN ACCORDANCE WITH
PRODUCT MANUAL:
921163600_08_019 (GREEK)
921163600_09_020 (ENGLISH)

POWER SUPPLY:  14
220-240V AC/50-60Hz

EN 54-2:1997 +A1:2006 0848
EN 54-4:1997 +A1:2002 +A2:2006
0848-CPR-002
DoP No: 921163200_59_003
Provided option:
Output to fire alarm device(s),
delays to outputs
**DISCONNECT POWER BEFORE
SERVICING**
Production
Date:

KOLINDROS PIERIAS
60061 GREECE

~~olympia electronics~~ 

BS-1634

CONVENTIONAL 4-ZONE
FIRE ALARM PANEL
INSTALL IN ACCORDANCE WITH
PRODUCT MANUAL:
921163600_08_019 (GREEK)
921163600_09_020 (ENGLISH)

POWER SUPPLY:  14
220-240V AC/50-60Hz

EN 54-2:1997 +A1:2006 0848
EN 54-4:1997 +A1:2002 +A2:2006
0848-CPR-003
DoP No: 921163400_59_003
Provided option:
Output to fire alarm device(s),
delays to outputs
**DISCONNECT POWER BEFORE
SERVICING**
Production
Date:

KOLINDROS PIERIAS
60061 GREECE

~~olympia electronics~~ 

BS-1636

CONVENTIONAL 6-ZONE
FIRE ALARM PANEL
INSTALL IN ACCORDANCE WITH
PRODUCT MANUAL:
921163600_08_019 (GREEK)
921163600_09_020 (ENGLISH)

POWER SUPPLY:  14
220-240V AC/50-60Hz

EN 54-2:1997 +A1:2006 0848
EN 54-4:1997 +A1:2002 +A2:2006
0848-CPR-004
DoP No: 921163600_59_003
Provided option:
Output to fire alarm device(s),
delays to outputs
**DISCONNECT POWER BEFORE
SERVICING**
Production
Date:

KOLINDROS PIERIAS
60061 GREECE