

PNP medium power transistor

Features

- High current
- Low saturation voltage
- Complement to 2SD882

Applications

- Voltage regulation
- Relay driver
- Generic switch
- Audio power amplifier
- DC-DC converter

Description

The device is a PNP transistor manufactured by using planar Technology resulting in rugged high performance devices. The complementary NPN type is 2SD882.

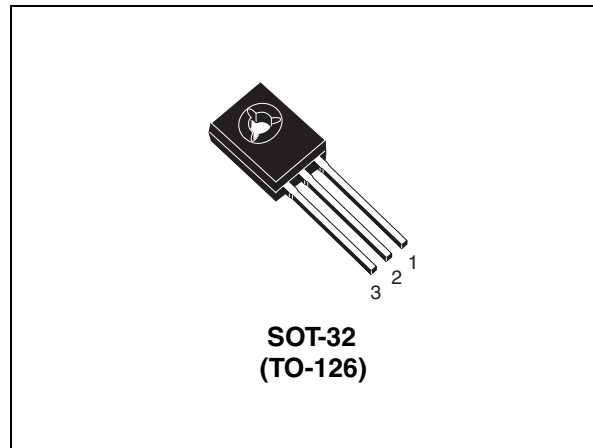

Figure 1. Internal schematic diagram

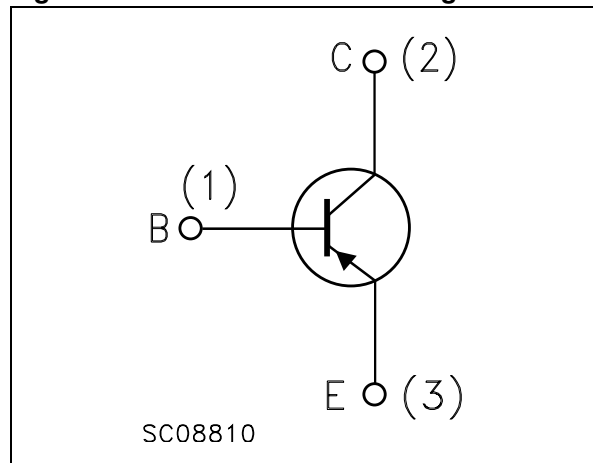

Table 1. Device summary

Order code	Marking	Package	Packing
2SB772	B772	SOT-32	Tube

1 Absolute maximum ratings

Table 2. Absolute maximum rating

Symbol	Parameter	Value	Unit
V_{CBO}	Collector-base voltage ($I_E = 0$)	-60	V
V_{CEO}	Collector-emitter voltage ($I_B = 0$)	-30	V
V_{EBO}	Collector-base voltage ($I_C = 0$)	-5	V
I_C	Collector current	-3	A
I_{CM}	Collector peak current ($t_P < 5\text{ms}$)	-6	A
I_B	Base current	-1	A
I_{BM}	Base peak current ($t_P < 5\text{ms}$)	-2	A
P_{TOT}	Total dissipation at $T_c = 25^\circ\text{C}$	12.5	W
T_{STG}	Storage temperature	-65 to 150	$^\circ\text{C}$
T_J	Max. operating junction temperature	150	$^\circ\text{C}$

Table 3. Thermal data

Symbol	Parameter	Value	Unit
$R_{thJ-case}$	Thermal resistance junction-case max	10	$^\circ\text{C}/\text{W}$

2 Electrical characteristics

($T_{CASE} = 25^{\circ}C$; unless otherwise specified)

Table 4. Electrical characteristics

Symbol	Parameter	Test conditions	Min.	Typ.	Max.	Unit
I_{CES}	Collector cut-off current ($V_{BE} = 0$)	$V_{CE} = -60$ V			-10	μA
I_{CEO}	Collector cut-off current ($I_B = 0$)	$V_{CE} = -30$ V			-100	μA
I_{EBO}	Emitter cut-off current ($I_C = 0$)	$V_{EB} = -5$ V			-10	μA
$V_{(BR)CEO(1)}$	Collector-emitter breakdown voltage ($I_B = 0$)	$I_C = -10$ mA	-30			V
$V_{(BR)CBO}$	Collector-base breakdown voltage ($I_E = 0$)	$I_C = -100$ μA	-60			V
$V_{(BR)EBO}$	Emitter-base breakdown voltage ($I_C = 0$)	$I_E = -100$ μA	-5			V
$V_{CE(sat)(1)}$	Collector-emitter saturation voltage	$I_C = -1$ A $I_B = -50$ mA $I_C = -2$ A $I_B = -100$ mA $I_C = -3$ A $I_B = -150$ mA			-0.4 -0.7 -1.1	V V V
$V_{BE(sat)(1)}$	Base-emitter saturation voltage	$I_C = -2$ A $I_B = -100$ mA			-1.2	V
h_{FE}	DC current gain	$I_C = -100$ mA $V_{CE} = -2$ V $I_C = -1$ A $V_{CE} = -2$ V $I_C = -3$ A $V_{CE} = -2$ V	100 80 30		300	
f_T	Transition frequency	$I_C = -0.1$ $V_{CE} = -10$ V		100		MHz

1. Pulsed duration = 300 ms, duty cycle $\leq 1.5\%$.

2.1 Typical characteristics (curves)

Figure 2. Reverse biased safe operating area Figure 3. DC current gain

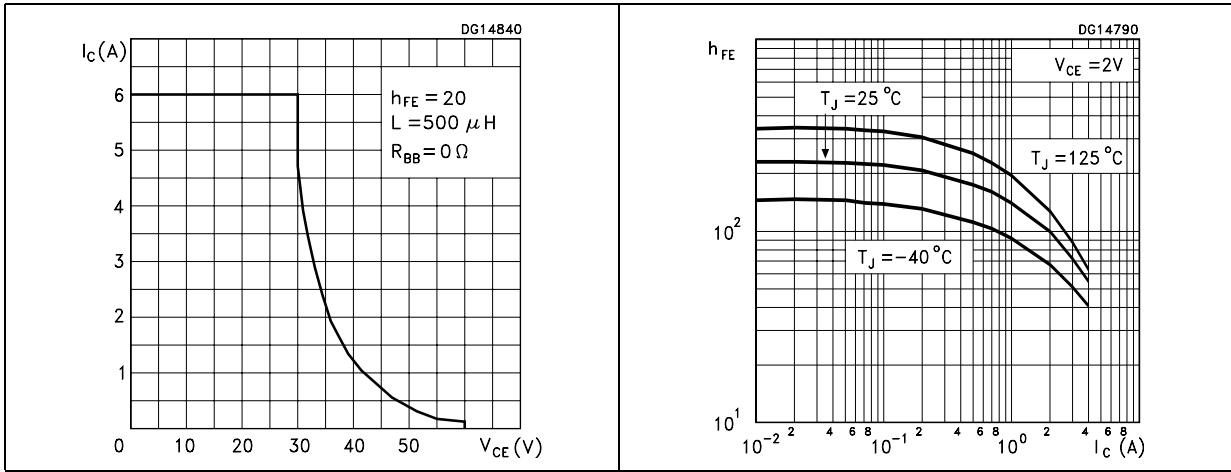
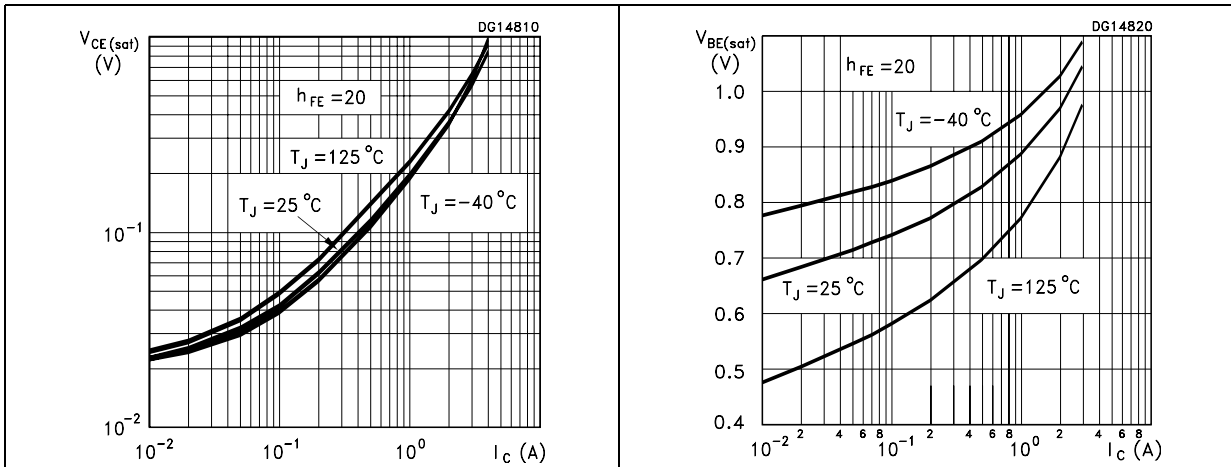

Figure 4. Collector-emitter saturation voltage Figure 5. Base-emitter saturation voltage



3 Package mechanical data

In order to meet environmental requirements, ST offers these devices in ECOPACK® packages. These packages have a Lead-free second level interconnect . The category of second level interconnect is marked on the package and on the inner box label, in compliance with JEDEC Standard JESD97. The maximum ratings related to soldering conditions are also marked on the inner box label. ECOPACK is an ST trademark. ECOPACK specifications are available at: www.st.com

SOT-32 (TO-126) mechanical data

DIM.	mm.		
	MIN.	TYP	MAX.
A	2.4		2.9
B	0.64		0.88
B1	0.39		0.63
D	10.5		11.05
E	7.4		7.8
e	2.04	2.29	2.54
e1	4.07	4.58	5.08
L	15.3		16
P	2.9		3.2
Q	8		
Q1	1		1.52
H2		2.15	
I	2		

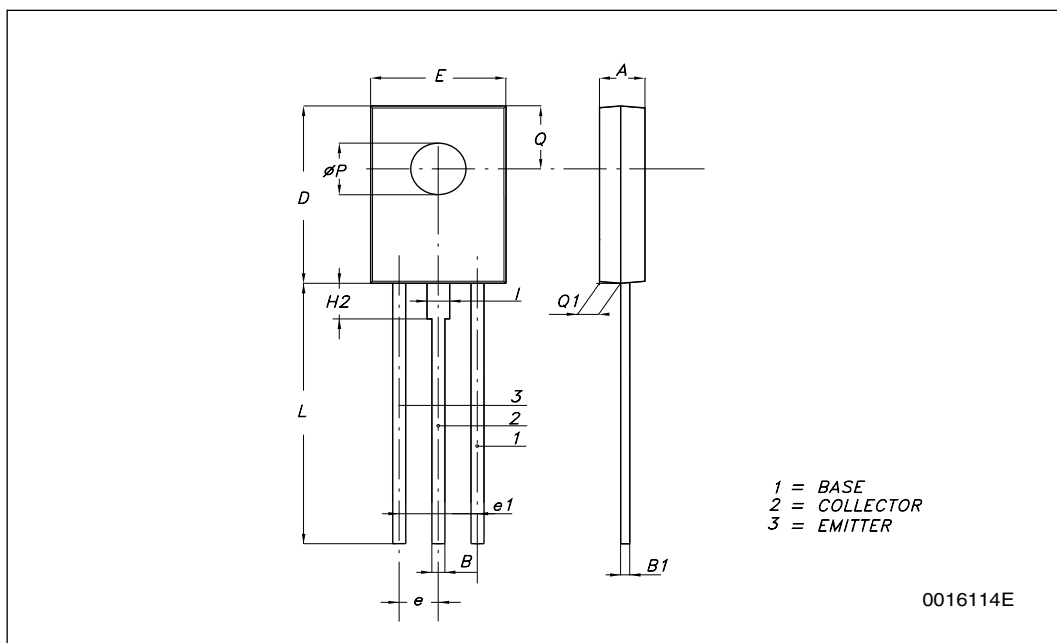

4 Revision History

Table 5. Document revision history

Date	Revision	Changes
09-Sep-2005	2	Final version. New template
02-Oct-2007	3	Updated mechanical data