2SB649, 2SB649A

Silicon PNP Epitaxial

HITACHI

ADE-208-856 (Z)

1st. Edition

Sep. 2000

Application

Low frequency power amplifier complementary pair with 2SD669/A

Outline

TO-126 MOD

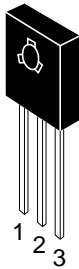

1. Emitter
2. Collector
3. Base

2SB649, 2SB649A

Absolute Maximum Ratings (Ta = 25°C)

Item	Symbol	Ratings		Unit
		2SB649	2SB649A	
Collector to base voltage	V_{CBO}	-180	-180	V
Collector to emitter voltage	V_{CEO}	-120	-160	V
Emitter to base voltage	V_{EBO}	-5	-5	V
Collector current	I_C	-1.5	-1.5	A
Collector peak current	$I_{C(peak)}$	-3	-3	A
Collector power dissipation	P_C	1	1	W
	P_C^{*1}	20	20	W
Junction temperature	T_j	150	150	°C
Storage temperature	T_{stg}	-55 to +150	-55 to +150	°C

Note: 1. Value at $T_C = 25^\circ\text{C}$

Electrical Characteristics (Ta = 25°C)

Item	Symbol	2SB649			2SB649A			Unit	Test conditions
		Min	Typ	Max	Min	Typ	Max		
Collector to base breakdown voltage	$V_{(BR)CBO}$	-180	—	—	-180	—	—	V	$I_C = -1 \text{ mA}, I_E = 0$
Collector to emitter breakdown voltage	$V_{(BR)CEO}$	-120	—	—	-160	—	—	V	$I_C = -10 \text{ mA}, R_{BE} = \infty$
Emitter to base breakdown voltage	$V_{(BR)EBO}$	-5	—	—	-5	—	—	V	$I_E = -1 \text{ mA}, I_C = 0$
Collector cutoff current	I_{CBO}	—	—	-10	—	—	-10	μA	$V_{CB} = -160 \text{ V}, I_E = 0$
DC current transfer ratio	h_{FE1}^{*1}	60	—	320	60	—	200		$V_{CE} = -5 \text{ V}, I_C = -150 \text{ mA}$
	h_{FE2}	30	—	—	30	—	—		$V_{CE} = -5 \text{ V}, I_C = -500 \text{ mA}^{*2}$
Collector to emitter saturation voltage	$V_{CE(sat)}$	—	—	-1	—	—	-1	V	$I_C = -500 \text{ mA}, I_B = -50 \text{ mA}$
Base to emitter voltage	V_{BE}	—	—	-1.5	—	—	-1.5	V	$V_{CE} = -5 \text{ V}, I_C = -150 \text{ mA}$
Gain bandwidth product	f_T	—	140	—	—	140	—	MHz	$V_{CE} = -5 \text{ V}, I_C = -150 \text{ mA}$
Collector output capacitance	Cob	—	27	—	—	27	—	pF	$V_{CB} = -10 \text{ V}, I_E = 0, f = 1 \text{ MHz}$

Notes: 1. The 2SB649 and 2SB649A are grouped by h_{FE1} as follows.

2. Pulse test

	B	C	D
2SB649	60 to 120	100 to 200	160 to 320
2SB649A	60 to 120	100 to 200	—

Maximum Collector Dissipation Curve

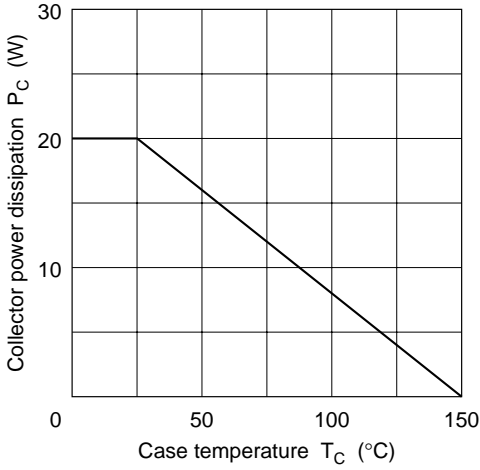

Area of Safe Operation

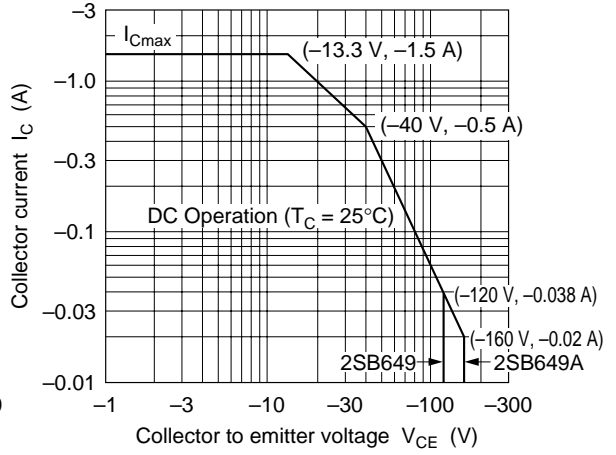

Typical Output Characteristics

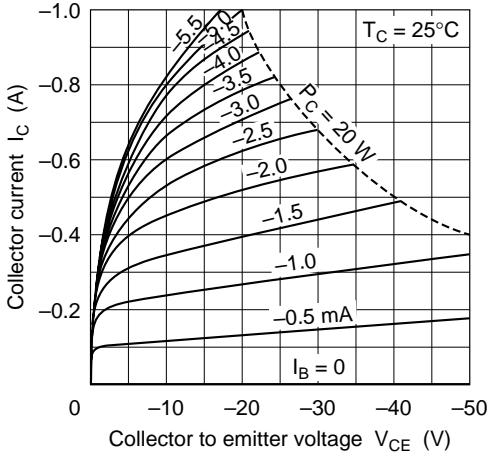

Typical Transfer Characteristics

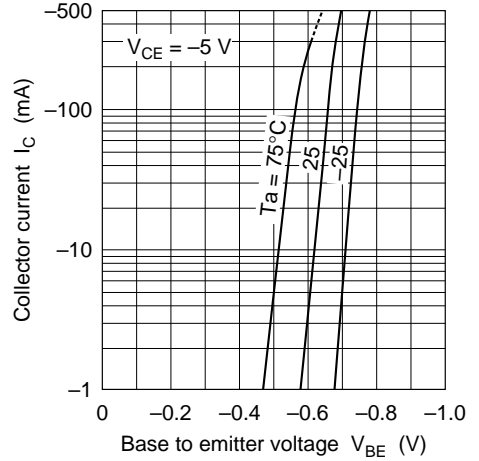

DC Current Transfer Ratio vs. Collector Current

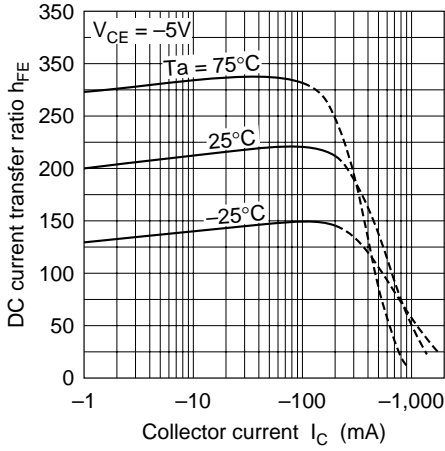

Collector to Emitter Saturation Voltage vs. Collector Current

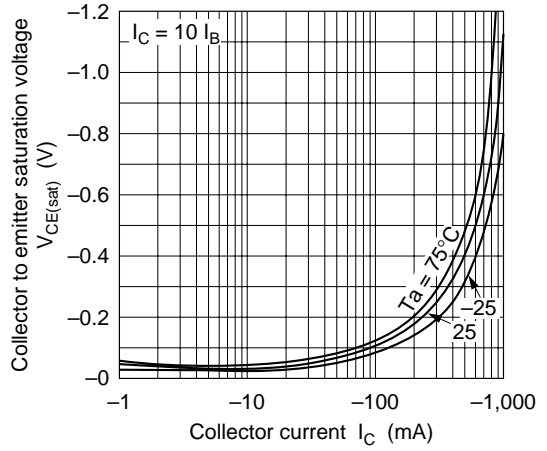

Base to Emitter Saturation Voltage vs. Collector Current

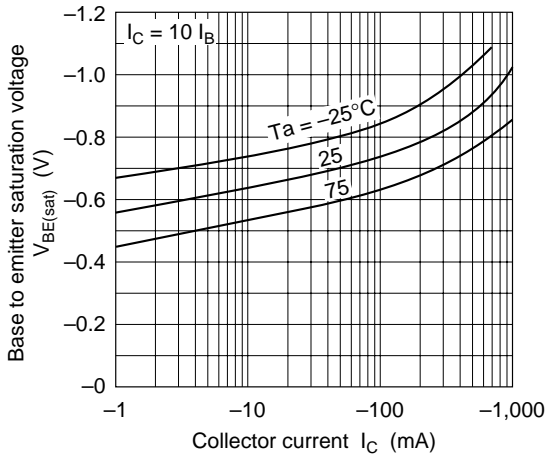

Gain Bandwidth Product vs. Collector Current

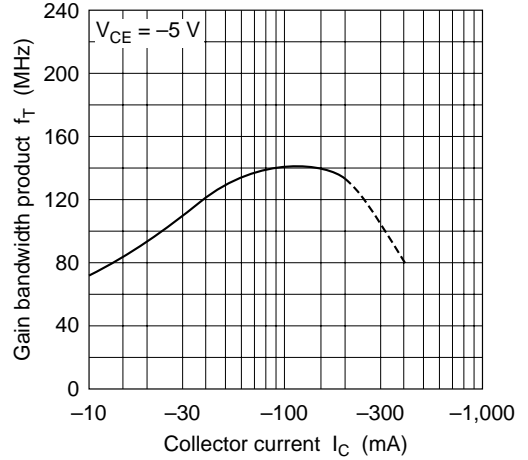

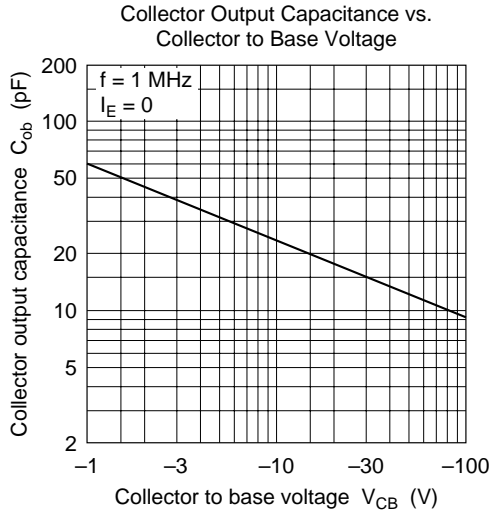

Package Dimensions

Unit: mm

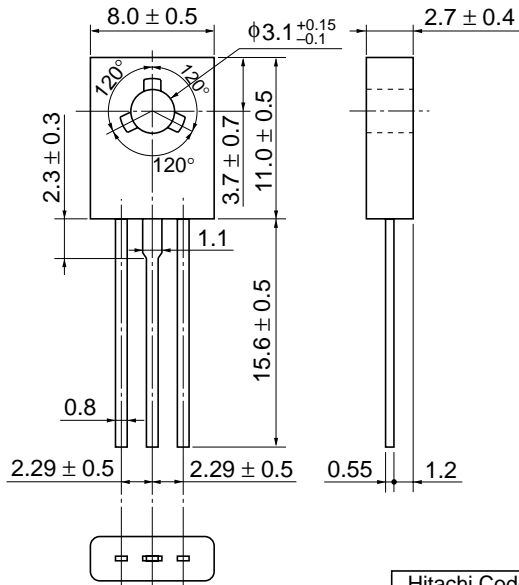

Hitachi Code	TO-126 Mod
JEDEC	—
EIAJ	—
Mass (reference value)	0.67 g