

DATA SHEET

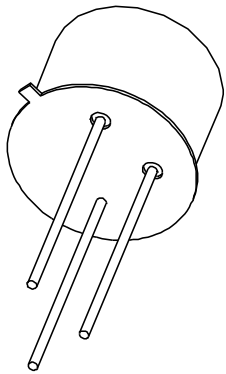

2N2905; 2N2905A PNP switching transistors

Product specification

Supersedes data of September 1994

File under Discrete Semiconductors, SC04

PNP switching transistors

2N2905; 2N2905A

FEATURES

- High current (max. 600 mA)
- Low voltage (max. 60 V).

APPLICATIONS

- High-speed switching
- Driver applications for industrial service.

DESCRIPTION

PNP switching transistor in a TO-39 metal package.
 NPN complements: 2N2219 and 2N2219A.

PINNING

PIN	DESCRIPTION
1	emitter
2	base
3	collector, connected to case

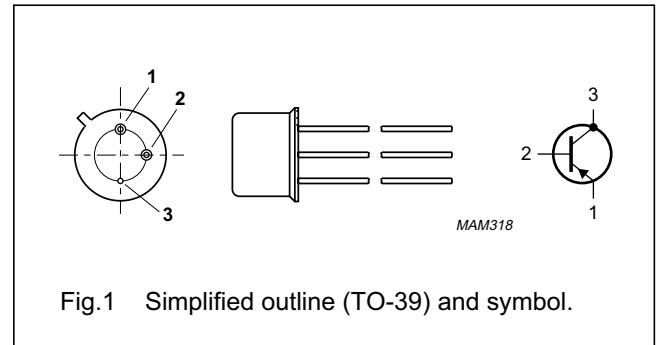

Fig. 1 Simplified outline (TO-39) and symbol.

QUICK REFERENCE DATA

SYMBOL	PARAMETER	CONDITIONS	MIN.	MAX.	UNIT
V_{CBO}	collector-base voltage	open emitter	–	–60	V
V_{CEO}	collector-emitter voltage 2N2905 2N2905A	open base	–	–40	V
			–	–60	V
I_C	collector current (DC)		–	–600	mA
P_{tot}	total power dissipation	$T_{amb} \leq 25\text{ }^\circ\text{C}$	–	600	mW
h_{FE}	DC current gain	$I_C = -150\text{ mA}; V_{CE} = -10\text{ V}$	100	300	
f_T	transition frequency	$I_C = -50\text{ mA}; V_{CE} = -20\text{ V}; f = 100\text{ MHz}$	200	–	MHz
t_{off}	turn-off time	$I_{Con} = -150\text{ mA}; I_{Bon} = -15\text{ mA}; I_{Boff} = 15\text{ mA}$	–	300	ns

PNP switching transistors

2N2905; 2N2905A

LIMITING VALUES

In accordance with the Absolute Maximum Rating System (IEC 134).

SYMBOL	PARAMETER	CONDITIONS	MIN.	MAX.	UNIT
V_{CBO}	collector-base voltage	open emitter	–	–60	V
V_{CEO}	collector-emitter voltage 2N2905 2N2905A	open base	–	–40	V
			–	–60	V
V_{EBO}	emitter-base voltage	open collector	–	–5	V
I_C	collector current (DC)		–	–600	mA
I_{CM}	peak collector current		–	–800	mA
I_{BM}	peak base current		–	–200	mA
P_{tot}	total power dissipation	$T_{amb} \leq 25\text{ °C}$	–	600	mW
		$T_{case} \leq 25\text{ °C}$	–	3	W
T_{stg}	storage temperature		–65	+150	°C
T_j	junction temperature		–	200	°C
T_{amb}	operating ambient temperature		–65	+150	°C

THERMAL CHARACTERISTICS

SYMBOL	PARAMETER	CONDITIONS	VALUE	UNIT
$R_{th\ j-a}$	thermal resistance from junction to ambient	in free air	292	K/W
$R_{th\ j-c}$	thermal resistance from junction to case		58	K/W

PNP switching transistors

2N2905; 2N2905A

CHARACTERISTICS

$T_{amb} = 25\text{ °C}$ unless otherwise specified.

SYMBOL	PARAMETER	CONDITIONS	MIN.	MAX.	UNIT
I_{CBO}	collector cut-off current 2N2905	$I_E = 0; V_{CB} = -50\text{ V}$	–	–20	nA
		$I_E = 0; V_{CB} = -50\text{ V}; T_{amb} = 150\text{ °C}$	–	–20	μA
I_{CBO}	collector cut-off current 2N2905A	$I_E = 0; V_{CB} = -50\text{ V}$	–	–10	nA
		$I_E = 0; V_{CB} = -50\text{ V}; T_{amb} = 150\text{ °C}$	–	–10	μA
I_{EBO}	emitter cut-off current	$I_C = 0; V_{EB} = -5\text{ V}$	–	50	nA
h_{FE}	DC current gain 2N2905	$V_{CE} = -10\text{ V}$ $I_C = -0.1\text{ mA}$	35	–	
		$I_C = -1\text{ mA}$	50	–	
		$I_C = -10\text{ mA}$	75	–	
		$I_C = -150\text{ mA}; \text{note 1}$	100	300	
		$I_C = -500\text{ mA}; \text{note 1}$	30	–	
h_{FE}	DC current gain 2N2905A	$V_{CE} = -10\text{ V}$ $I_C = -0.1\text{ mA}$	75	–	
		$I_C = -1\text{ mA}$	100	–	
		$I_C = -10\text{ mA}$	100	–	
		$I_C = -150\text{ mA}; \text{note 1}$	100	300	
		$I_C = -500\text{ mA}; \text{note 1}$	50	–	
V_{CEsat}	collector-emitter saturation voltage	$I_C = -150\text{ mA}; I_B = -15\text{ mA}; \text{note 1}$	–	–400	mV
		$I_C = -500\text{ mA}; I_B = -50\text{ mA}; \text{note 1}$	–	–1.6	V
V_{BEsat}	base-emitter saturation voltage	$I_C = -150\text{ mA}; I_B = -15\text{ mA}; \text{note 1}$	–	–1.3	V
		$I_C = -500\text{ mA}; I_B = -50\text{ mA}; \text{note 1}$	–	–2.6	V
C_c	collector capacitance	$I_E = i_e = 0; V_{CB} = -10\text{ V}; f = 1\text{ MHz}$	–	8	pF
C_e	emitter capacitance	$I_C = i_c = 0; V_{EB} = -2\text{ V}; f = 1\text{ MHz}$	–	30	pF
f_T	transition frequency	$I_C = -50\text{ mA}; V_{CE} = -20\text{ V}; f = 100\text{ MHz}; \text{note 1}$	200	–	MHz
Switching times (between 10% and 90% levels); see Fig.2					
t_{on}	turn-on time	$I_{Con} = -150\text{ mA}; I_{Bon} = -15\text{ mA}; I_{Boff} = 15\text{ mA}$	–	45	ns
t_d	delay time		–	15	ns
t_r	rise time		–	35	ns
t_{off}	turn-off time		–	300	ns
t_s	storage time		–	250	ns
t_f	fall time		–	50	ns

Note

1. Pulse test: $t_p \leq 300\text{ }\mu\text{s}$; $\delta \leq 0.02$.

PNP switching transistors

2N2905; 2N2905A

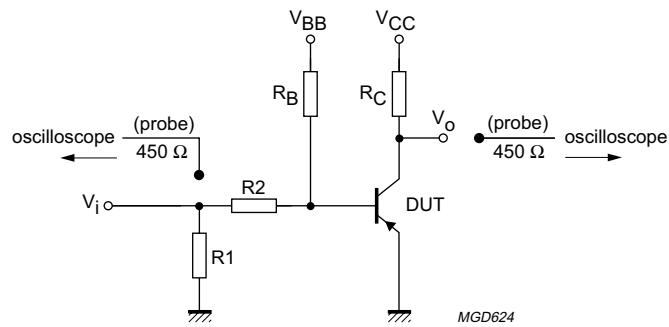

$V_i = -9.5 \text{ V}$; $T = 500 \text{ } \mu\text{s}$; $t_p = 10 \text{ } \mu\text{s}$; $t_r = t_f \leq 3 \text{ ns}$.
 $R_1 = 68 \text{ } \Omega$; $R_2 = 325 \text{ } \mu\text{s}$; $R_B = 325 \text{ } \Omega$; $R_C = 160 \text{ } \Omega$.
 $V_{BB} = 3.5 \text{ V}$; $V_{CC} = -29.5 \text{ V}$.
Oscilloscope input impedance $Z_i = 50 \text{ } \Omega$.

Fig.2 Test circuit for switching times.

PNP switching transistors

2N2905; 2N2905A

PACKAGE OUTLINE

Metal-can cylindrical single-ended package; 3 leads

SOT5/11

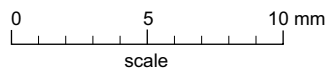
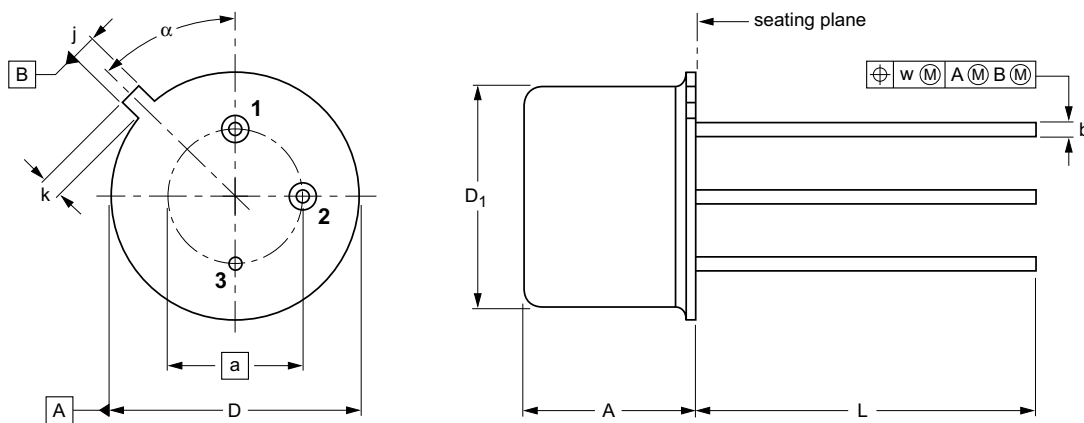

DIMENSIONS (mm are the original dimensions)

UNIT	A	a	b	D	D ₁	j	k	L	w	α
mm	6.60	0.48	9.39	8.33	0.85	0.95	14.2	0.2	45°	
	6.35	5.08	0.41	9.08	8.18	0.75	0.75	12.7		

OUTLINE VERSION	REFERENCES				EUROPEAN PROJECTION	ISSUE DATE
	IEC	JEDEC	EIAJ			
SOT5/11		TO-39				97-04-11

PNP switching transistors

2N2905; 2N2905A

DEFINITIONS

Data sheet status	
Objective specification	This data sheet contains target or goal specifications for product development.
Preliminary specification	This data sheet contains preliminary data; supplementary data may be published later.
Product specification	This data sheet contains final product specifications.
Limiting values	
Limiting values given are in accordance with the Absolute Maximum Rating System (IEC 134). Stress above one or more of the limiting values may cause permanent damage to the device. These are stress ratings only and operation of the device at these or at any other conditions above those given in the Characteristics sections of the specification is not implied. Exposure to limiting values for extended periods may affect device reliability.	
Application information	
Where application information is given, it is advisory and does not form part of the specification.	

LIFE SUPPORT APPLICATIONS

These products are not designed for use in life support appliances, devices, or systems where malfunction of these products can reasonably be expected to result in personal injury. Philips customers using or selling these products for use in such applications do so at their own risk and agree to fully indemnify Philips for any damages resulting from such improper use or sale.