

High-Voltage Switching Applications**Features**

- High speed (Adoption of MBIT process).
- High breakdown voltage ($V_{CBO}=1500V$).
- High reliability (Adoption of HVP process).
- On-chip damper diode.

Package Dimensions

unit:mm

2039D

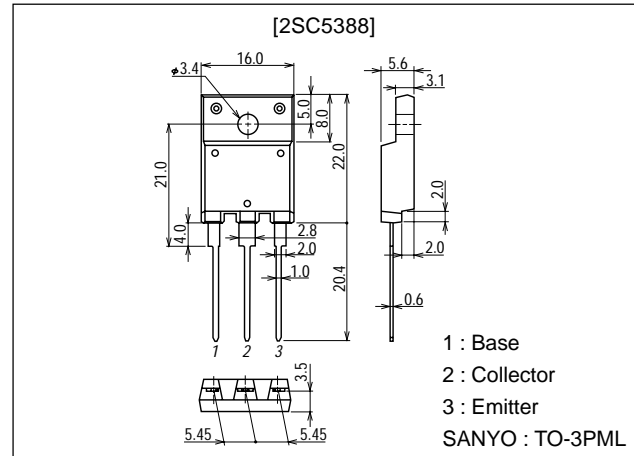
**Specifications****Absolute Maximum Ratings** at $T_a = 25^\circ C$

Parameter	Symbol	Conditions	Ratings	Unit
Collector-to-Base Voltage	V_{CBO}		1500	V
Collector-to-Emitter Voltage	V_{CEO}		700	V
Emitter-to-Base Voltage	V_{EBO}		5	V
Collector Current	I_C		5	A
Collector Current (Pulse)	I_{CP}		10	A
Base Current	I_B		1	A
Collector Dissipation	P_C		3.0	W
		$T_c=25^\circ C$	50	W
Junction Temperature	T_j		150	$^\circ C$
Storage Temperature	T_{stg}		-55 to +150	$^\circ C$

Electrical Characteristics at $T_a = 25^\circ C$

Parameter	Symbol	Conditions	Ratings			Unit
			min	typ	max	
Collector Cutoff Current	I_{CBO}	$V_{CB}=700V, I_E=0$			0.1	mA
Emitter Cutoff Current	I_{EBO}	$V_{EB}=5V, I_C=0$			600	mA
DC Current Gain	h_{FE1}	$V_{CE}=5V, I_C=1A$	100		230	
	h_{FE2}	$V_{CE}=5V, I_C=5A$	50		150	

Continued on next page.

■ Any and all SANYO products described or contained herein do not have specifications that can handle applications that require extremely high levels of reliability, such as life-support systems, aircraft's control systems, or other applications whose failure can be reasonably expected to result in serious physical and/or material damage. Consult with your SANYO representative nearest you before using any SANYO products described or contained herein in such applications.

■ SANYO assumes no responsibility for equipment failures that result from using products at values that exceed, even momentarily, rated values (such as maximum ratings, operating condition ranges, or other parameters) listed in products specifications of any and all SANYO products described or contained herein.

2SC5388

Continued from preceding page.

Parameter	Symbol	Conditions	Ratings			Unit
			min	typ	max	
Collector-to-Emitter Sustain Voltage	$V_{CEO(sus)}$	$I_C=100mA, I_B=0$	700			V
Collector-to-Emitter Saturation Voltage	$V_{CE(sat)}$	$I_C=5A, I_B=0.5A$			1.5	V
Base-to-Emitter Saturation Voltage	$V_{BE(sat)}$	$I_C=5A, I_B=0.5A$			2.0	V
Collector-to-Base Breakdown Voltage	$V_{(BR)CBO}$	$I_C=1mA, I_E=0$	1500			V
Diode Forward Voltage	V_F	$I_{EC}=5A$			2.0	V
Fall Time	t_f	$I_C=5A, I_{B1}=0.5A, I_{B2}=-2.5A, V_{CC}=200V, R_L=40\Omega$			0.8	μs
Storage Time	t_{stg}	$I_C=5A, I_{B1}=0.5A, I_{B2}=-2.5A, V_{CC}=200V, R_L=40\Omega$			3	μs

Switching Time Test Circuit

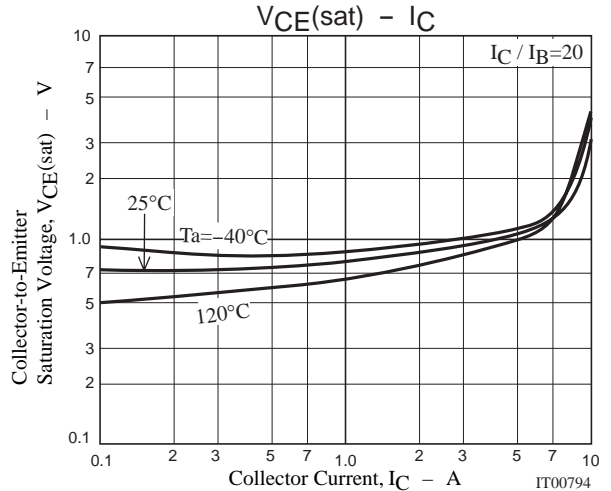
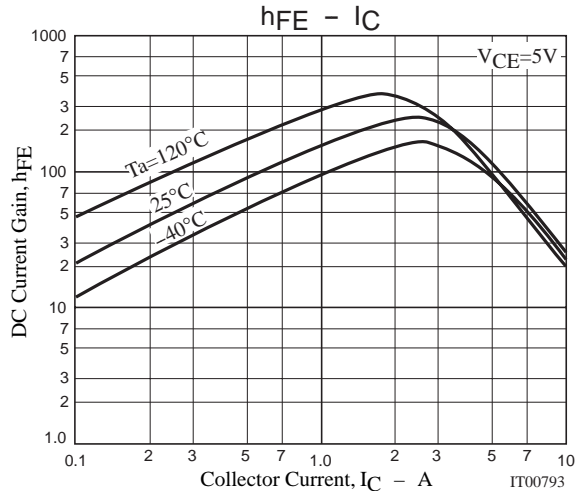
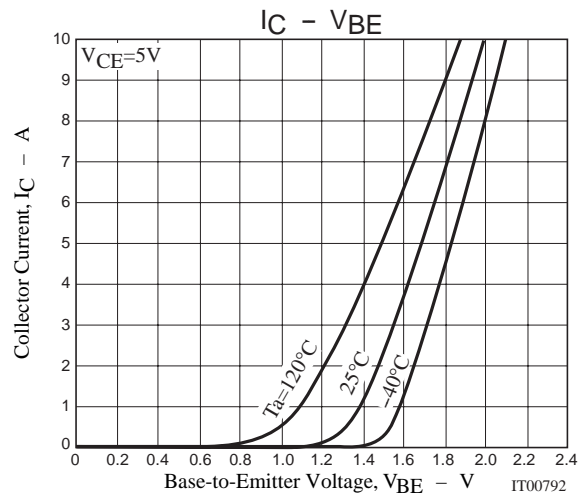
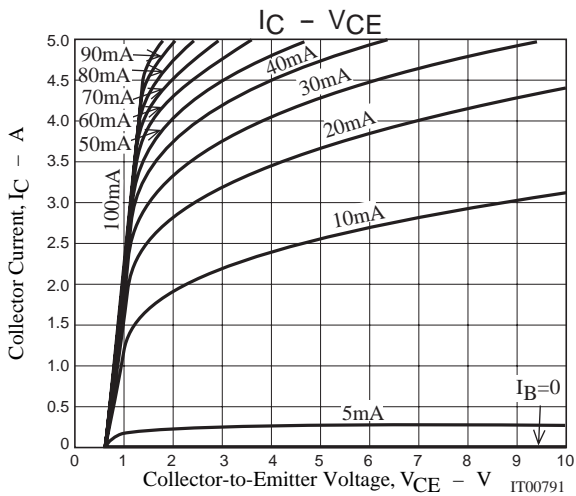
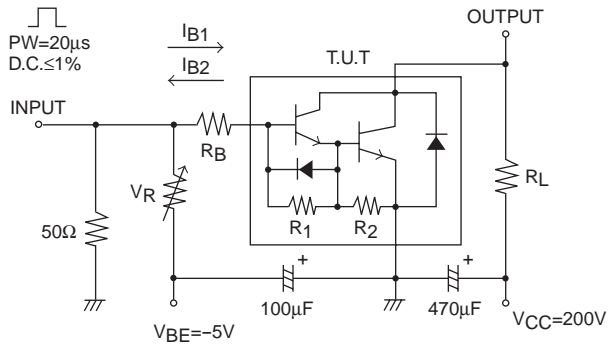

2SC5388

