

## 256K I<sup>2</sup>C™ CMOS Serial EEPROM

### Device Selection Table

| Part Number | Vcc Range | Max. Clock Frequency   | Temp. Ranges |
|-------------|-----------|------------------------|--------------|
| 24AA256     | 1.7-5.5V  | 400 kHz <sup>(1)</sup> | I, E         |
| 24LC256     | 2.5-5.5V  | 400 kHz                | I, E         |
| 24FC256     | 1.7-5.5V  | 1 MHz <sup>(2)</sup>   | I            |

**Note 1:** 100 kHz for Vcc < 2.5V.

**Note 2:** 400 kHz for Vcc < 2.5V.

### Features:

- Single Supply with Operation Down to 1.7V for 24AA256 and 24FC256 Devices, 2.5V for 24LC256 Devices
- Low-Power CMOS Technology:
  - Active current 400 uA, typical
  - Standby current 100 nA, typical
- 2-Wire Serial Interface, I<sup>2</sup>C™ Compatible
- Cascadable up to Eight Devices
- Schmitt Trigger Inputs for Noise Suppression
- Output Slope Control to Eliminate Ground Bounce
- 100 kHz and 400 kHz Clock Compatibility
- Page Write Time 5 ms Max.
- Self-Timed Erase/Write Cycle
- 64-Byte Page Write Buffer
- Hardware Write-Protect
- ESD Protection >4000V
- More than One Million Erase/Write Cycles
- Data Retention >200 years
- Factory Programming Available
- Packages Include 8-lead PDIP, SOIC, DFN, TDFN, TSSOP and MSOP
- Pb-Free and RoHS Compliant

### Package Types

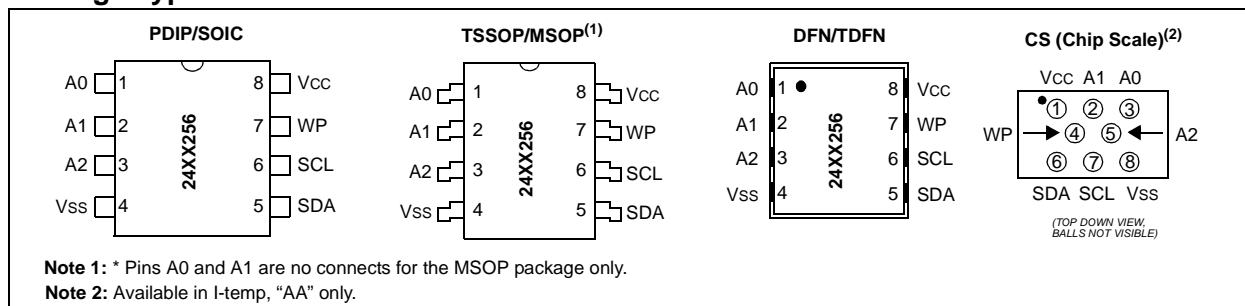

- Temperature Ranges:
  - Industrial (I): -40°C to +85°C
  - Automotive (E): -40°C to +125°C

### Description:

The Microchip Technology Inc. 24AA256/24LC256/24FC256 (24XX256\*) is a 32K x 8 (256 Kbit) Serial Electrically Erasable PROM, capable of operation across a broad voltage range (1.7V to 5.5V). It has been developed for advanced, low-power applications such as personal communications or data acquisition. This device also has a page write capability of up to 64 bytes of data. This device is capable of both random and sequential reads up to the 256K boundary. Functional address lines allow up to eight devices on the same bus, for up to 2 Mbit address space. This device is available in the standard 8-pin plastic DIP, SOIC, TSSOP, MSOP, DFN and TDFN packages. The 24AA256 is also available in the 8-lead Chip Scale package.

### Block Diagram

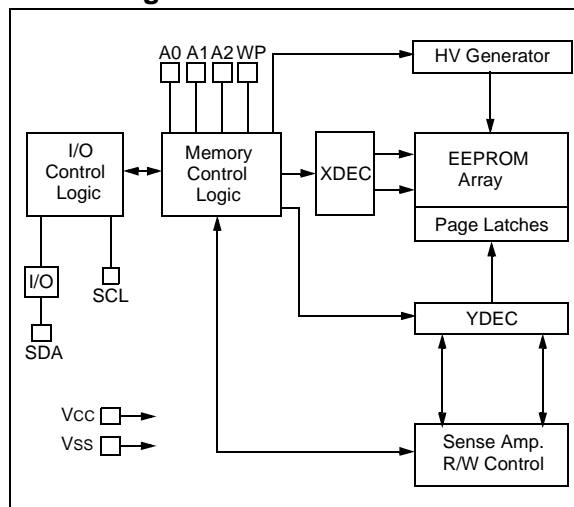

\*24XX256 is used in this document as a generic part number for the 24AA256/24LC256/24FC256 devices.

# 24AA256/24LC256/24FC256

## 1.0 ELECTRICAL CHARACTERISTICS

### Absolute Maximum Ratings<sup>(†)</sup>

|   |                                |
|---|--------------------------------|
| V <sub>CC</sub> .....                               | 6.5V                           |
| All inputs and outputs w.r.t. V <sub>SS</sub> ..... | -0.6V to V <sub>CC</sub> +1.0V |
| Storage temperature .....                           | -65°C to +150°C                |
| Ambient temperature with power applied.....         | -40°C to +125°C                |
| ESD protection on all pins .....                    | ≥ 4 kV                         |

† NOTICE: Stresses above those listed under “Absolute Maximum Ratings” may cause permanent damage to the device. This is a stress rating only and functional operation of the device at these or any other conditions above those indicated in the operational listings of this specification is not implied. Exposure to Absolute Maximum Rating conditions for extended periods may affect device reliability.

**TABLE 1-1: DC CHARACTERISTICS**

| DC CHARACTERISTICS |                                       |  | Electrical Characteristics:                     |  |                                  |  |
|--------------------|---------------------------------------|--|---|--|----------------------------------|--|
|                    |                                       |  | Industrial (I): V <sub>CC</sub> = +1.7V to 5.5V |  | T <sub>A</sub> = -40°C to +85°C  |  |
|                    |                                       |  | Automotive (E): V <sub>CC</sub> = +1.7V to 5.5V |  | T <sub>A</sub> = -40°C to +125°C |  |
| Param. No.         | Sym.                                  | Characteristic                                       | Min.  | Max.                                       | Units                            | Conditions   |
|                    | —                                     | A0, A1, A2, SCL, SDA and WP pins:                    | —   | —  | —                                | —  |
| D1                 | V <sub>IH</sub>                       | High-level input voltage                             | 0.7 V <sub>CC</sub>                             | —  | V                                | —  |
| D2                 | V <sub>IL</sub>                       | Low-level input voltage                              | —   | 0.3 V <sub>CC</sub><br>0.2 V <sub>CC</sub> | V<br>V                           | V <sub>CC</sub> ≥ 2.5V<br>V <sub>CC</sub> < 2.5V   |
| D3                 | V <sub>HYS</sub>                      | Hysteresis of Schmitt Trigger inputs (SDA, SCL pins) | 0.05 V <sub>CC</sub>                            | —  | V                                | V <sub>CC</sub> ≥ 2.5V ( <b>Note</b> )   |
| D4                 | V <sub>OL</sub>                       | Low-level output voltage                             | —   | 0.40                                       | V                                | I <sub>OL</sub> = 3.0 ma @ V <sub>CC</sub> = 4.5V<br>I <sub>OL</sub> = 2.1 ma @ V <sub>CC</sub> = 2.5V   |
| D5                 | I <sub>LI</sub>                       | Input leakage current                                | —   | ±1   | μA                               | V <sub>IN</sub> = V <sub>SS</sub> or V <sub>CC</sub> , WP = V <sub>SS</sub><br>V <sub>IN</sub> = V <sub>SS</sub> or V <sub>CC</sub> , WP = V <sub>CC</sub> |
| D6                 | I <sub>LO</sub>                       | Output leakage current                               | —   | ±1   | μA                               | V <sub>OUT</sub> = V <sub>SS</sub> or V <sub>CC</sub>  |
| D7                 | C <sub>IN</sub> ,<br>C <sub>OUT</sub> | Pin capacitance (all inputs/outputs)                 | —   | 10   | pF                               | V <sub>CC</sub> = 5.0V ( <b>Note</b> )<br>T <sub>A</sub> = 25°C, F <sub>CLK</sub> = 1 MHz  |
| D8                 | I <sub>CC</sub> Read                  | Operating current                                    | —   | 400  | μA                               | V <sub>CC</sub> = 5.5V, SCL = 400 kHz  |
|                    | I <sub>CC</sub> Write                 |  | —   | 3  | mA                               | V <sub>CC</sub> = 5.5V   |
| D9                 | I <sub>CCS</sub>                      | Standby current                                      | —   | 1  | μA                               | T <sub>A</sub> = -40°C to +85°C<br>SCL = SDA = V <sub>CC</sub> = 5.5V<br>A0, A1, A2, WP = V <sub>SS</sub>  |
|                    |                                       |  | —   | 5  | μA                               | T <sub>A</sub> = -40°C to +125°C<br>SCL = SDA = V <sub>CC</sub> = 5.5V<br>A0, A1, A2, WP = V <sub>SS</sub>   |

**Note:** This parameter is periodically sampled and not 100% tested.

# 24AA256/24LC256/24FC256

**TABLE 1-2: AC CHARACTERISTICS**

| AC CHARACTERISTICS |         |                                   | Electrical Characteristics: |      |                                 |                                       |
|--------------------|---------|-----------------------------------|-----------------------------|------|---------------------------------|---------------------------------------|
|                    |         |                                   | Industrial (I):             |      | V <sub>CC</sub> = +1.7V to 5.5V | T <sub>A</sub> = -40°C to +85°C       |
|                    |         |                                   | Automotive (E):             |      | V <sub>CC</sub> = +1.7V to 5.5V | T <sub>A</sub> = -40°C to +125°C      |
| Param. No.         | Sym.    | Characteristic                    | Min.                        | Max. | Units                           | Conditions                            |
| 1                  | FCLK    | Clock frequency                   | —                           | 100  | kHz                             | 1.7V ≤ V <sub>CC</sub> < 2.5V         |
|                    |         |                                   | —                           | 400  |                                 | 2.5V ≤ V <sub>CC</sub> ≤ 5.5V         |
|                    |         |                                   | —                           | 400  |                                 | 1.7V ≤ V <sub>CC</sub> < 2.5V 24FC256 |
|                    |         |                                   | —                           | 1000 |                                 | 2.5V ≤ V <sub>CC</sub> ≤ 5.5V 24FC256 |
| 2                  | THIGH   | Clock high time                   | 4000                        | —    | ns                              | 1.7V ≤ V <sub>CC</sub> < 2.5V         |
|                    |         |                                   | 600                         | —    |                                 | 2.5V ≤ V <sub>CC</sub> ≤ 5.5V         |
|                    |         |                                   | 600                         | —    |                                 | 1.7V ≤ V <sub>CC</sub> < 2.5V 24FC256 |
|                    |         |                                   | 500                         | —    |                                 | 2.5V ≤ V <sub>CC</sub> ≤ 5.5V 24FC256 |
| 3                  | TLOW    | Clock low time                    | 4700                        | —    | ns                              | 1.7V ≤ V <sub>CC</sub> < 2.5V         |
|                    |         |                                   | 1300                        | —    |                                 | 2.5V ≤ V <sub>CC</sub> ≤ 5.5V         |
|                    |         |                                   | 1300                        | —    |                                 | 1.7V ≤ V <sub>CC</sub> < 2.5V 24FC256 |
|                    |         |                                   | 500                         | —    |                                 | 2.5V ≤ V <sub>CC</sub> ≤ 5.5V 24FC256 |
| 4                  | TR      | SDA and SCL rise time<br>(Note 1) | —                           | 1000 | ns                              | 1.7V ≤ V <sub>CC</sub> < 2.5V         |
|                    |         |                                   | —                           | 300  |                                 | 2.5V ≤ V <sub>CC</sub> ≤ 5.5V         |
|                    |         |                                   | —                           | 300  |                                 | 1.7V ≤ V <sub>CC</sub> ≤ 5.5V 24FC256 |
| 5                  | TF      | SDA and SCL fall time<br>(Note 1) | —                           | 300  | ns                              | All except, 24FC256                   |
|                    |         |                                   | —                           | 100  |                                 | 1.7V ≤ V <sub>CC</sub> ≤ 5.5V 24FC256 |
| 6                  | THD:STA | Start condition hold time         | 4000                        | —    | ns                              | 1.7V ≤ V <sub>CC</sub> < 2.5V         |
|                    |         |                                   | 600                         | —    |                                 | 2.5V ≤ V <sub>CC</sub> ≤ 5.5V         |
|                    |         |                                   | 600                         | —    |                                 | 1.7V ≤ V <sub>CC</sub> < 2.5V 24FC256 |
|                    |         |                                   | 250                         | —    |                                 | 2.5V ≤ V <sub>CC</sub> ≤ 5.5V 24FC256 |
| 7                  | TSU:STA | Start condition setup time        | 4700                        | —    | ns                              | 1.7V ≤ V <sub>CC</sub> < 2.5V         |
|                    |         |                                   | 600                         | —    |                                 | 2.5V ≤ V <sub>CC</sub> ≤ 5.5V         |
|                    |         |                                   | 600                         | —    |                                 | 1.7V ≤ V <sub>CC</sub> < 2.5V 24FC256 |
|                    |         |                                   | 250                         | —    |                                 | 2.5V ≤ V <sub>CC</sub> ≤ 5.5V 24FC256 |
| 8                  | THD:DAT | Data input hold time              | 0                           | —    | ns                              | (Note 2)                              |
| 9                  | TSU:DAT | Data input setup time             | 250                         | —    | ns                              | 1.7V ≤ V <sub>CC</sub> < 2.5V         |
|                    |         |                                   | 100                         | —    |                                 | 2.5V ≤ V <sub>CC</sub> ≤ 5.5V         |
|                    |         |                                   | 100                         | —    |                                 | 1.7V ≤ V <sub>CC</sub> ≤ 5.5V 24FC256 |
| 10                 | TSU:STO | Stop condition setup time         | 4000                        | —    | ns                              | 1.7V ≤ V <sub>CC</sub> < 2.5V         |
|                    |         |                                   | 600                         | —    |                                 | 2.5V ≤ V <sub>CC</sub> ≤ 5.5V         |
|                    |         |                                   | 600                         | —    |                                 | 1.7V ≤ V <sub>CC</sub> < 2.5V 24FC256 |
|                    |         |                                   | 250                         | —    |                                 | 2.5V ≤ V <sub>CC</sub> ≤ 5.5V 24FC256 |
| 11                 | TSU:WP  | WP setup time                     | 4000                        | —    | ns                              | 1.7V ≤ V <sub>CC</sub> < 2.5V         |
|                    |         |                                   | 600                         | —    |                                 | 2.5V ≤ V <sub>CC</sub> ≤ 5.5V         |
|                    |         |                                   | 600                         | —    |                                 | 1.7V ≤ V <sub>CC</sub> ≤ 5.5V 24FC256 |
| 12                 | THD:WP  | WP hold time                      | 4700                        | —    | ns                              | 1.7V ≤ V <sub>CC</sub> < 2.5V         |
|                    |         |                                   | 1300                        | —    |                                 | 2.5V ≤ V <sub>CC</sub> ≤ 5.5V         |
|                    |         |                                   | 1300                        | —    |                                 | 1.7V ≤ V <sub>CC</sub> ≤ 5.5V 24FC256 |

**Note 1:** Not 100% tested. CB = total capacitance of one bus line in pF.

- 2:** As a transmitter, the device must provide an internal minimum delay time to bridge the undefined region (minimum 300 ns) of the falling edge of SCL to avoid unintended generation of Start or Stop conditions.
- 3:** The combined TSP and VHYS specifications are due to new Schmitt Trigger inputs, which provide improved noise spike suppression. This eliminates the need for a Ti specification for standard operation.
- 4:** This parameter is not tested but ensured by characterization. For endurance estimates in a specific application, please consult the Total Endurance™ Model, which can be obtained from Microchip's web site at [www.microchip.com](http://www.microchip.com).

# 24AA256/24LC256/24FC256

| AC CHARACTERISTICS (Continued) |      |   | Electrical Characteristics: |                           |                            |  |
|--------------------------------|------|---|-----------------------------|---------------------------|----------------------------|--|
|                                |      |   | Industrial (I):             |                           | $V_{CC} = +1.7V$ to $5.5V$ | $T_A = -40^{\circ}C$ to $+85^{\circ}C$   |
|                                |      |   | Automotive (E):             |                           | $V_{CC} = +1.7V$ to $5.5V$ | $T_A = -40^{\circ}C$ to $+125^{\circ}C$  |
| Param. No.                     | Sym. | Characteristic  | Min.                        | Max.                      | Units                      | Conditions   |
| 13                             | TAA  | Output valid from clock<br>(Note 2)   | —                           | 3500<br>900<br>900<br>400 | ns                         | $1.7V \leq V_{CC} < 2.5V$<br>$2.5V \leq V_{CC} \leq 5.5V$<br>$1.7V \leq V_{CC} < 2.5V$ 24FC256<br>$2.5V \leq V_{CC} \leq 5.5V$ 24FC256 |
| 14                             | TBUF | Bus free time: Time the bus must be free before a new transmission can start    | 4700<br>1300<br>1300<br>500 | —                         | ns                         | $1.7V \leq V_{CC} < 2.5V$<br>$2.5V \leq V_{CC} \leq 5.5V$<br>$1.7V \leq V_{CC} < 2.5V$ 24FC256<br>$2.5V \leq V_{CC} \leq 5.5V$ 24FC256 |
| 15                             | TOF  | Output fall time from $V_{IH}$ minimum to $V_{IL}$ maximum<br>$C_B \leq 100$ pF | $10 + 0.1C_B$               | 250<br>250                | ns                         | All except, 24FC256 (Note 1)   |
| 16                             | TSP  | Input filter spike suppression (SDA and SCL pins)                               | —                           | 50                        | ns                         | All except, 24FC256 (Notes 1 and 3)  |
| 17                             | TWC  | Write cycle time (byte or page)   | —                           | 5                         | ms                         | —  |
| 18                             | —    | Endurance   | 1,000,000                   | —                         | cycles                     | Page mode, $25^{\circ}C$ , $5.5V$ (Note 4)   |

**Note 1:** Not 100% tested.  $C_B$  = total capacitance of one bus line in pF.

**Note 2:** As a transmitter, the device must provide an internal minimum delay time to bridge the undefined region (minimum 300 ns) of the falling edge of SCL to avoid unintended generation of Start or Stop conditions.

**Note 3:** The combined TSP and  $V_{HYS}$  specifications are due to new Schmitt Trigger inputs, which provide improved noise spike suppression. This eliminates the need for a  $T_i$  specification for standard operation.

**Note 4:** This parameter is not tested but ensured by characterization. For endurance estimates in a specific application, please consult the Total Endurance™ Model, which can be obtained from Microchip's web site at [www.microchip.com](http://www.microchip.com).

**FIGURE 1-1: BUS TIMING DATA**

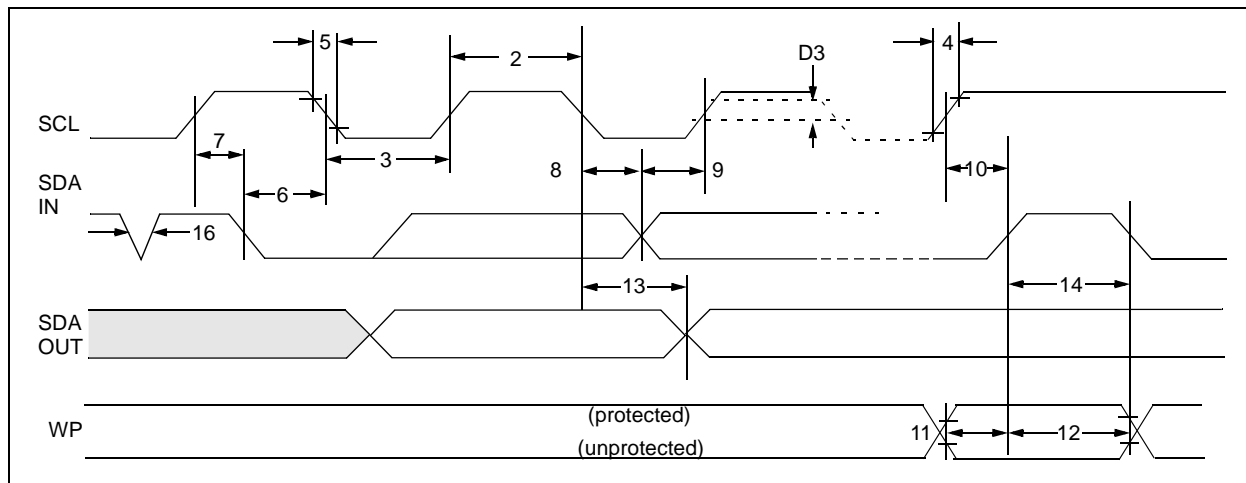

# 24AA256/24LC256/24FC256

## 2.0 PIN DESCRIPTIONS

The descriptions of the pins are listed in [Table 2-1](#).

**TABLE 2-1: PIN FUNCTION TABLE**

| Name | 8-pin PDIP | 8-pin SOIC | 8-pin TSSOP | 8-pin MSOP | 8-pin DFN/TDFN | CS | Function  |
|------|------------|------------|-------------|------------|----------------|----|---|
| A0   | 1          | 1          | 1           | —          | 1              | 3  | User Configurable Chip Select   |
| A1   | 2          | 2          | 2           | —          | 2              | 2  | User Configurable Chip Select   |
| (NC) | —          | —          | —           | 1, 2       | —              | —  | Not Connected   |
| A2   | 3          | 3          | 3           | 3          | 3              | 5  | User Configurable Chip Select   |
| Vss  | 4          | 4          | 4           | 4          | 4              | 8  | Ground  |
| SDA  | 5          | 5          | 5           | 5          | 5              | 6  | Serial Data   |
| SCL  | 6          | 6          | 6           | 6          | 6              | 7  | Serial Clock  |
| (NC) | —          | —          | —           | —          | —              | —  | Not Connected   |
| WP   | 7          | 7          | 7           | 7          | 7              | 4  | Write-Protect Input   |
| Vcc  | 8          | 8          | 8           | 8          | 8              | 1  | +1.7V to 5.5V (24AA256)<br>+2.5V to 5.5V (24LC256)<br>+1.7V to 5.5V (24FC256) |

**Note:** Exposed pad on DFN/TDFN can be connected to VSS or left floating.

### 2.1 A0, A1, A2 Chip Address Inputs

The A0, A1 and A2 inputs are used by the 24XX256 for multiple device operations. The levels on these inputs are compared with the corresponding bits in the slave address. The chip is selected if the compare is true.

For the MSOP package only, pins A0 and A1 are not connected.

Up to eight devices (two for the MSOP package) may be connected to the same bus by using different Chip Select bit combinations. These inputs must be connected to either VCC or VSS.

In most applications, the chip address inputs A0, A1 and A2 are hard-wired to logic '0' or logic '1'. For applications in which these pins are controlled by a microcontroller or other programmable device, the chip address pins must be driven to logic '0' or logic '1' before normal device operation can proceed.

### 2.2 Serial Data (SDA)

This is a bidirectional pin used to transfer addresses and data into and out of the device. It is an open drain terminal. Therefore, the SDA bus requires a pull-up resistor to Vcc (typical 10 k $\Omega$  for 100 kHz, 2 k $\Omega$  for 400 kHz and 1 MHz).

For normal data transfer, SDA is allowed to change only during SCL low. Changes during SCL high are reserved for indicating the Start and Stop conditions.

### 2.3 Serial Clock (SCL)

This input is used to synchronize the data transfer to and from the device.

### 2.4 Write-Protect (WP)

This pin must be connected to either Vss or Vcc. If tied to Vss, write operations are enabled. If tied to VCC, write operations are inhibited but read operations are not affected.

## 3.0 FUNCTIONAL DESCRIPTION

The 24XX256 supports a bidirectional 2-wire bus and data transmission protocol. A device that sends data onto the bus is defined as a transmitter and a device receiving data as a receiver. The bus must be controlled by a master device which generates the Serial Clock (SCL), controls the bus access, and generates the Start and Stop conditions while the 24XX256 works as a slave. Both master and slave can operate as a transmitter or receiver, but the master device determines which mode is activated.

# 24AA256/24LC256/24FC256

---

## 4.0 BUS CHARACTERISTICS

The following **bus protocol** has been defined:

- Data transfer may be initiated only when the bus is not busy.
- During data transfer, the data line must remain stable whenever the clock line is high. Changes in the data line, while the clock line is high, will be interpreted as a Start or Stop condition.

Accordingly, the following bus conditions have been defined (Figure 4-1).

### 4.1 Bus Not Busy (A)

Both data and clock lines remain high.

### 4.2 Start Data Transfer (B)

A high-to-low transition of the SDA line while the clock (SCL) is high, determines a Start condition. All commands must be preceded by a Start condition.

### 4.3 Stop Data Transfer (C)

A low-to-high transition of the SDA line, while the clock (SCL) is high, determines a Stop condition. All operations must end with a Stop condition.

### 4.4 Data Valid (D)

The state of the data line represents valid data when, after a Start condition, the data line is stable for the duration of the high period of the clock signal.

The data on the line must be changed during the low period of the clock signal. There is one bit of data per clock pulse.

Each data transfer is initiated with a Start condition and terminated with a Stop condition. The number of the data bytes transferred between the Start and Stop conditions is determined by the master device.

### 4.5 Acknowledge

Each receiving device, when addressed, is obliged to generate an Acknowledge signal after the reception of each byte. The master device must generate an extra clock pulse which is associated with this Acknowledge bit.

**Note:** The 24XX256 does not generate any Acknowledge bits if an internal programming cycle is in progress.

A device that acknowledges must pull down the SDA line during the acknowledge clock pulse in such a way that the SDA line is stable low during the high period of the acknowledge related clock pulse. Of course, setup and hold times must be taken into account. During reads, a master must signal an end of data to the slave by NOT generating an Acknowledge bit on the last byte that has been clocked out of the slave. In this case, the slave (24XX256) will leave the data line high to enable the master to generate the Stop condition.

# 24AA256/24LC256/24FC256

**FIGURE 4-1: DATA TRANSFER SEQUENCE ON THE SERIAL BUS**

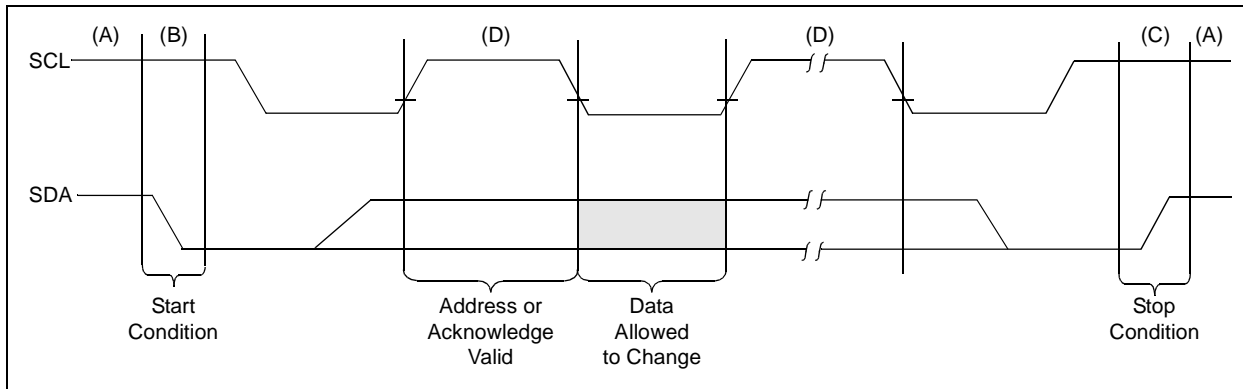

**FIGURE 4-2: ACKNOWLEDGE TIMING**

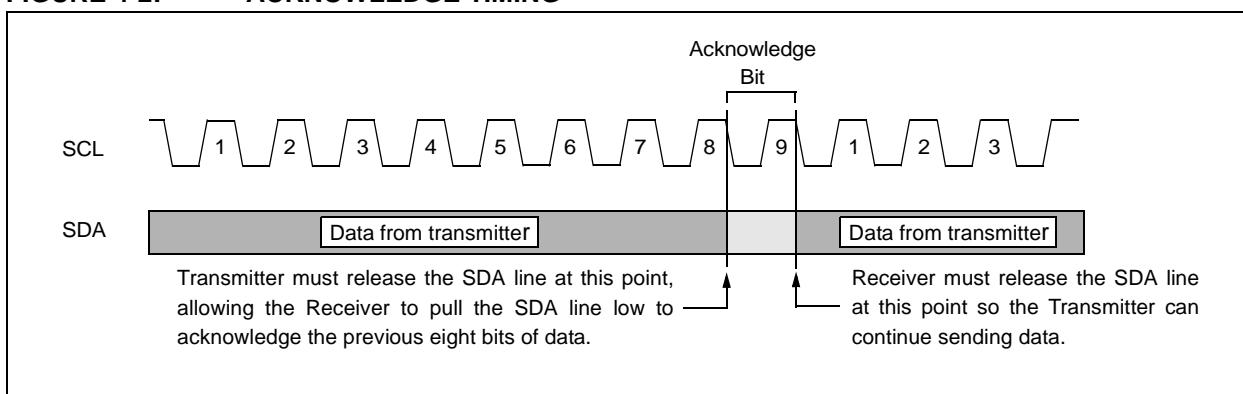

# 24AA256/24LC256/24FC256

## 5.0 DEVICE ADDRESSING

A control byte is the first byte received following the Start condition from the master device (Figure 5-1). The control byte consists of a 4-bit control code. For the 24XX256, this is set as '1010' binary for read and write operations. The next three bits of the control byte are the Chip Select bits (A2, A1, A0). The Chip Select bits allow the use of up to eight 24XX256 devices on the same bus and are used to select which device is accessed. The Chip Select bits in the control byte must correspond to the logic levels on the corresponding A2, A1 and A0 pins for the device to respond. These bits are, in effect, the three Most Significant bits of the word address.

For the MSOP package, the A0 and A1 pins are not connected. During device addressing, the A0 and A1 Chip Select bits (Figures 5-1 and 5-2) should be set to '0'. Only two 24XX256 MSOP packages can be connected to the same bus.

The last bit of the control byte defines the operation to be performed. When set to a one, a read operation is selected. When set to a zero, a write operation is selected. The next two bytes received define the address of the first data byte (Figure 5-2). Because only A14...A0 are used, the upper address bits are a "don't care." The upper address bits are transferred first, followed by the Less Significant bits.

Following the Start condition, the 24XX256 monitors the SDA bus checking the device type identifier being transmitted. Upon receiving a '1010' code and appropriate device select bits, the slave device outputs an Acknowledge signal on the SDA line. Depending on the state of the R/W bit, the 24XX256 will select a read or write operation.

FIGURE 5-1: CONTROL BYTE FORMAT

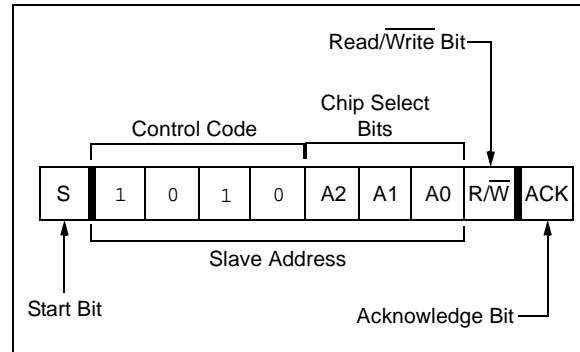

### 5.1 Contiguous Addressing Across Multiple Devices

The Chip Select bits A2, A1 and A0 can be used to expand the contiguous address space for up to 2 Mbit by adding up to eight 24XX256 devices on the same bus. In this case, software can use A0 of the **control byte** as address bit A15; A1 as address bit A16; and A2 as address bit A17. It is not possible to sequentially read across device boundaries.

For the MSOP package, up to two 24XX256 devices can be added for up to 512 Kbit of address space. In this case, software can use A2 of the control byte as address bit A17. Bits A0 (A15) and A1 (A16) of the **control byte** must always be set to a logic '0' for the MSOP.

FIGURE 5-2: ADDRESS SEQUENCE BIT ASSIGNMENTS

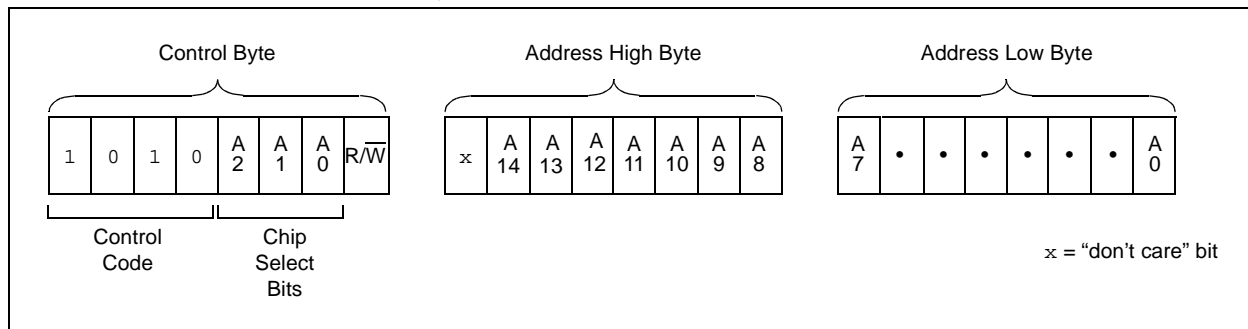

## 6.0 WRITE OPERATIONS

### 6.1 Byte Write

Following the Start condition from the master, the control code (four bits), the Chip Select (three bits) and the R/W bit (which is a logic low) are clocked onto the bus by the master transmitter. This indicates to the addressed slave receiver that the address high byte will follow after it has generated an Acknowledge bit during the ninth clock cycle. Therefore, the next byte transmitted by the master is the high-order byte of the word address and will be written into the Address Pointer of the 24XX256. The next byte is the Least Significant Address Byte. After receiving another Acknowledge signal from the 24XX256, the master device will transmit the data word to be written into the addressed memory location. The 24XX256 acknowledges again and the master generates a Stop condition. This initiates the internal write cycle and during this time, the 24XX256 will not generate Acknowledge signals (Figure 6-1). If an attempt is made to write to the array with the WP pin held high, the device will acknowledge the command but no write cycle will occur, no data will be written, and the device will immediately accept a new command. After a byte Write command, the internal address counter will point to the address location following the one that was just written.

**Note:** When doing a write of less than 64 bytes the data in the rest of the page is refreshed along with the data bytes being written. This will force the entire page to endure a write cycle, for this reason endurance is specified per page.

### 6.2 Page Write

The write control byte, word address and the first data byte are transmitted to the 24XX256 in much the same way as in a byte write. The exception is that instead of generating a Stop condition, the master transmits up to 63 additional bytes, which are temporarily stored in the on-chip page buffer, and will be written into memory once the master has transmitted a Stop condition. Upon receipt of each word, the six lower Address Pointer bits are internally incremented by one. If the master should transmit more than 64 bytes prior to generating the Stop condition, the address counter will roll over and the previously received data will be overwritten. As with the byte write operation, once the Stop condition is received, an internal write cycle will begin (Figure 6-2). If an attempt is made to write to the array with the WP pin held high, the device will acknowledge the command, but no write cycle will occur, no data will be written and the device will immediately accept a new command.

### 6.3 Write Protection

The WP pin allows the user to write-protect the entire array (0000-7FFF) when the pin is tied to VCC. If tied to VSS the write protection is disabled. The WP pin is sampled at the Stop bit for every Write command (Figure 1-1). Toggling the WP pin after the Stop bit will have no effect on the execution of the write cycle.

**Note:** Page write operations are limited to writing bytes within a single physical page, **regardless** of the number of bytes actually being written. Physical page boundaries start at addresses that are integer multiples of the page buffer size (or 'page size') and end at addresses that are integer multiples of [page size - 1]. If a Page Write command attempts to write across a physical page boundary, the result is that the data wraps around to the beginning of the current page (overwriting data previously stored there), instead of being written to the next page, as might be expected. It is, therefore, necessary for the application software to prevent page write operations that would attempt to cross a page boundary.

# 24AA256/24LC256/24FC256

**FIGURE 6-1: BYTE WRITE**

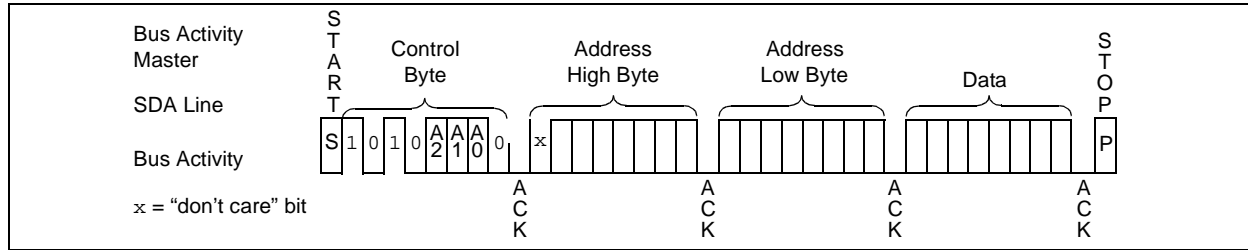

**FIGURE 6-2: PAGE WRITE**

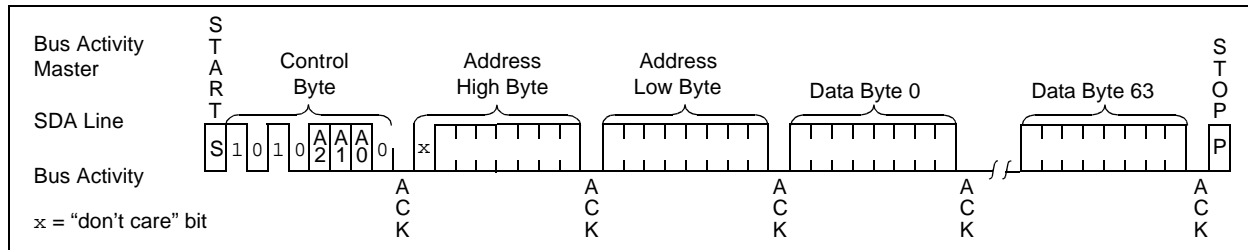

## 7.0 ACKNOWLEDGE POLLING

Since the device will not acknowledge during a write cycle, this can be used to determine when the cycle is complete (This feature can be used to maximize bus throughput). Once the Stop condition for a Write command has been issued from the master, the device initiates the internally timed write cycle. ACK polling can be initiated immediately. This involves the master sending a Start condition, followed by the control byte for a Write command ( $R/\overline{W} = 0$ ). If the device is still busy with the write cycle, then no ACK will be returned. If no ACK is returned, the Start bit and control byte must be resent. If the cycle is complete, then the device will return the ACK and the master can then proceed with the next Read or Write command. See [Figure 7-1](#) for flow diagram.

FIGURE 7-1: ACKNOWLEDGE POLLING FLOW

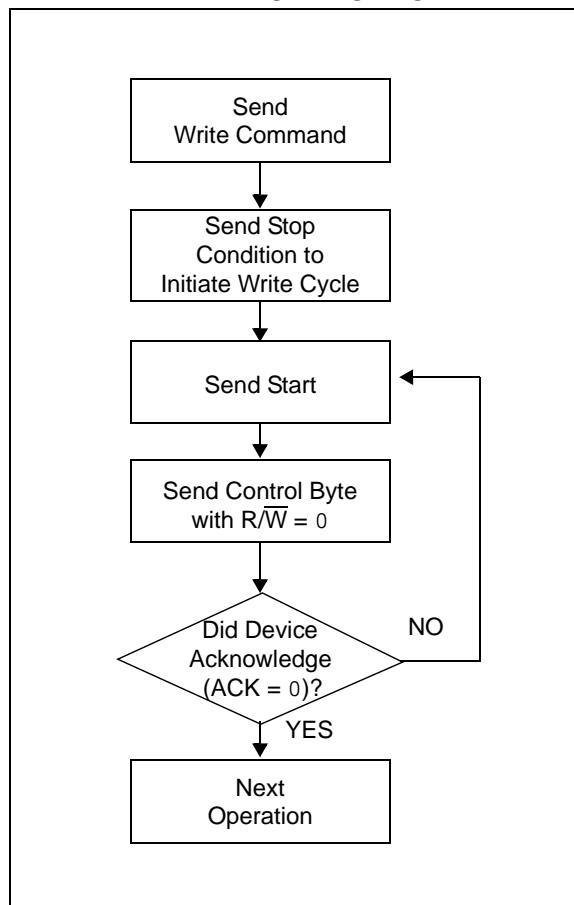

# 24AA256/24LC256/24FC256

## 8.0 READ OPERATION

Read operations are initiated in much the same way as write operations, with the exception that the  $R/\overline{W}$  bit of the control byte is set to '1'. There are three basic types of read operations: current address read, random read and sequential read.

### 8.1 Current Address Read

The 24XX256 contains an address counter that maintains the address of the last word accessed, internally incremented by '1'. Therefore, if the previous read access was to address 'n' (n is any legal address), the next current address read operation would access data from address n + 1.

Upon receipt of the control byte with  $R/\overline{W}$  bit set to '1', the 24XX256 issues an acknowledge and transmits the 8-bit data word. The master will not acknowledge the transfer, but does generate a Stop condition and the 24XX256 discontinues transmission (Figure 8-1).

**FIGURE 8-1: CURRENT ADDRESS READ**

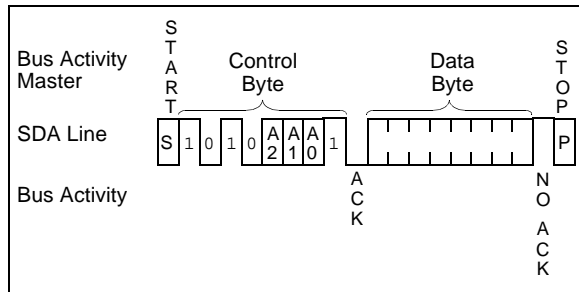

### 8.2 Random Read

Random read operations allow the master to access any memory location in a random manner. To perform this type of read operation, the word address must first be set. This is done by sending the word address to the 24XX256 as part of a write operation ( $R/\overline{W}$  bit set to '0'). Once the word address is sent, the master generates a Start condition following the acknowledge. This terminates the write operation, but not before the internal Address Pointer is set. The master then issues the control byte again, but with the  $R/\overline{W}$  bit set to a one. The 24XX256 will then issue an acknowledge and transmit the 8-bit data word. The master will not acknowledge the transfer, though it does generate a Stop condition, which causes the 24XX256 to discontinue transmission (Figure 8-2). After a random Read command, the internal address counter will point to the address location following the one that was just read.

### 8.3 Sequential Read

Sequential reads are initiated in the same way as a random read except that after the 24XX256 transmits the first data byte, the master issues an acknowledge as opposed to the Stop condition used in a random read. This acknowledge directs the 24XX256 to transmit the next sequentially addressed 8-bit word (Figure 8-3). Following the final byte transmitted to the master, the master will NOT generate an acknowledge, but will generate a Stop condition. To provide sequential reads, the 24XX256 contains an internal Address Pointer which is incremented by one at the completion of each operation. This Address Pointer allows the entire memory contents to be serially read during one operation. The internal Address Pointer will automatically roll over from address 7FFF to address 0000 if the master acknowledges the byte received from the array address 7FFF.

**FIGURE 8-2: RANDOM READ**

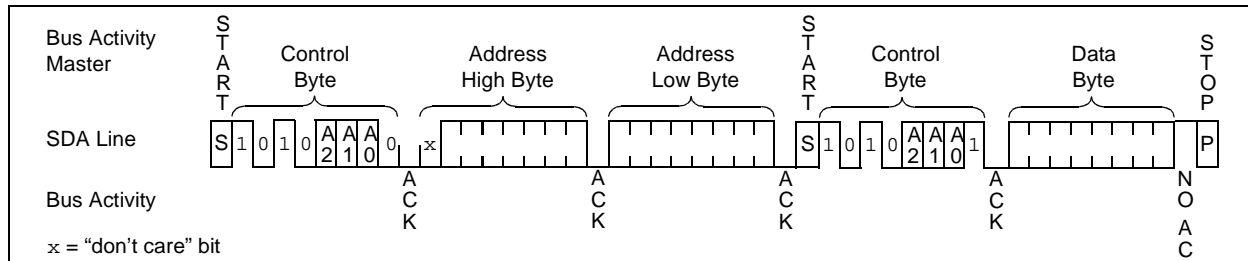

**FIGURE 8-3: SEQUENTIAL READ**

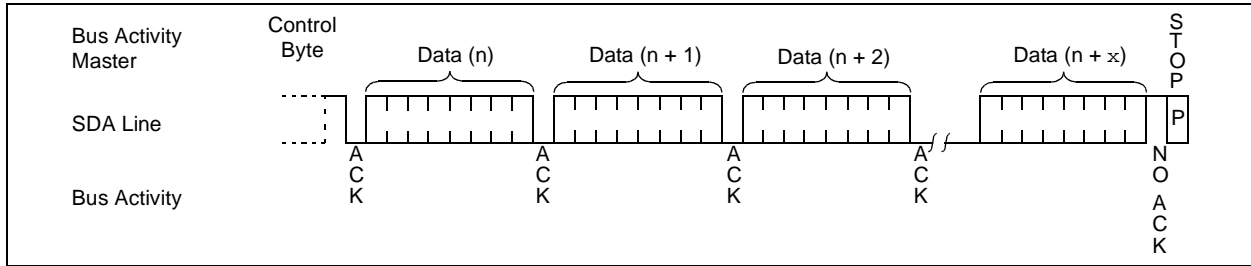

# 24AA256/24LC256/24FC256

## 9.0 PACKAGING INFORMATION

### 9.1 Package Marking Information

8-Lead PDIP (300 mil)

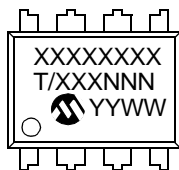

Example:

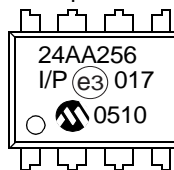

8-Lead SOIC (150 mil)

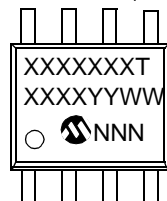

Example:



8-Lead SOIC (208 mil)

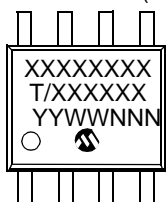

Example:

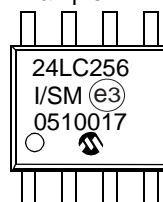

|                |        |  |
|----------------|--------|--|
| <b>Legend:</b> | XX...X | Part number or part number code                                  |
|                | T      | Temperature (I, E)   |
|                | Y      | Year code (last digit of calendar year)                          |
|                | YY     | Year code (last 2 digits of calendar year)                       |
|                | WW     | Week code (week of January 1 is week '01')                       |
|                | NNN    | Alphanumeric traceability code (2 characters for small packages) |
|                | (e3)   | Pb-free JEDEC designator for Matte Tin (Sn)                      |

**Note:** For very small packages with no room for the Pb-free JEDEC designator (e3), the marking will only appear on the outer carton or reel label.

**Note:** In the event the full Microchip part number cannot be marked on one line, it will be carried over to the next line, thus limiting the number of available characters for customer-specific information.

\*Standard device marking consists of Microchip part number, year code, week code, and traceability code. For device marking beyond this, certain price adders apply. Please check with your Microchip Sales Office.

# 24AA256/24LC256/24FC256

## Package Marking Information (Continued)

8-Lead TSSOP

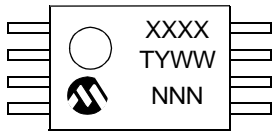

Example:

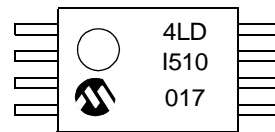

8-Lead MSOP

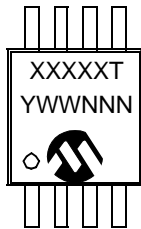

Example:



8-Lead DFN-S

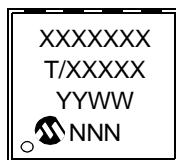

Example:

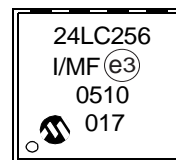

8-Lead TDFN

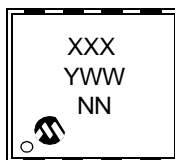

Example:

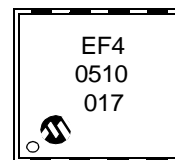

8-Lead Chip Scale

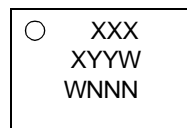

Example:

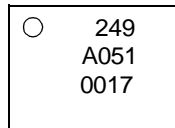

| Part No. | First Line Marking Codes |                    |                    |
|----------|--------------------------|--------------------|--------------------|
|          | TSSOP Package Codes      | MSOP Package Codes | TDFN Package Codes |
| 24AA256  | 4AD                      | 4A256T             | —                  |
| 24LC256  | 4LD                      | 4L256T             | EF4                |
| 24FC256  | 4FD                      | 4F256T             | —                  |

# 24AA256/24LC256/24FC256

## 8-Lead Plastic Dual In-Line (P) – 300 mil Body [PDIP]

**Note:** For the most current package drawings, please see the Microchip Packaging Specification located at <http://www.microchip.com/packaging>

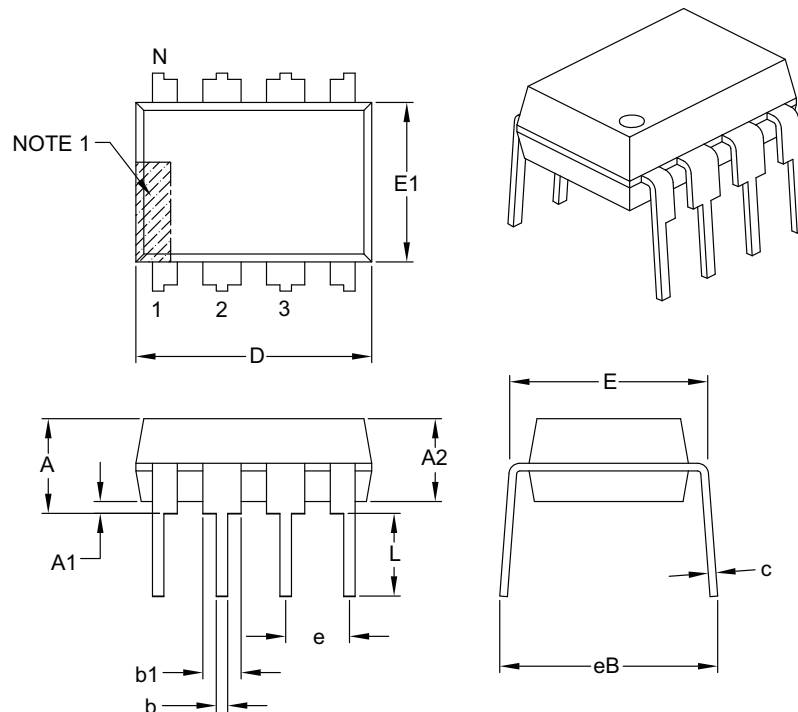

| Dimension Limits           | Units | INCHES   |      |      |
|----------------------------|-------|----------|------|------|
|                            |       | MIN      | NOM  | MAX  |
| Number of Pins             | N     | 8        |      |      |
| Pitch                      | e     | .100 BSC |      |      |
| Top to Seating Plane       | A     | –        | –    | .210 |
| Molded Package Thickness   | A2    | .115     | .130 | .195 |
| Base to Seating Plane      | A1    | .015     | –    | –    |
| Shoulder to Shoulder Width | E     | .290     | .310 | .325 |
| Molded Package Width       | E1    | .240     | .250 | .280 |
| Overall Length             | D     | .348     | .365 | .400 |
| Tip to Seating Plane       | L     | .115     | .130 | .150 |
| Lead Thickness             | c     | .008     | .010 | .015 |
| Upper Lead Width           | b1    | .040     | .060 | .070 |
| Lower Lead Width           | b     | .014     | .018 | .022 |
| Overall Row Spacing §      | eB    | –        | –    | .430 |

**Notes:**

- Pin 1 visual index feature may vary, but must be located with the hatched area.
- § Significant Characteristic.
- Dimensions D and E1 do not include mold flash or protrusions. Mold flash or protrusions shall not exceed .010" per side.
- Dimensioning and tolerancing per ASME Y14.5M.

BSC: Basic Dimension. Theoretically exact value shown without tolerances.

Microchip Technology Drawing C04-018B

# 24AA256/24LC256/24FC256

## 8-Lead Plastic Small Outline (SN) - Narrow, 3.90 mm Body [SOIC]

**Note:** For the most current package drawings, please see the Microchip Packaging Specification located at <http://www.microchip.com/packaging>

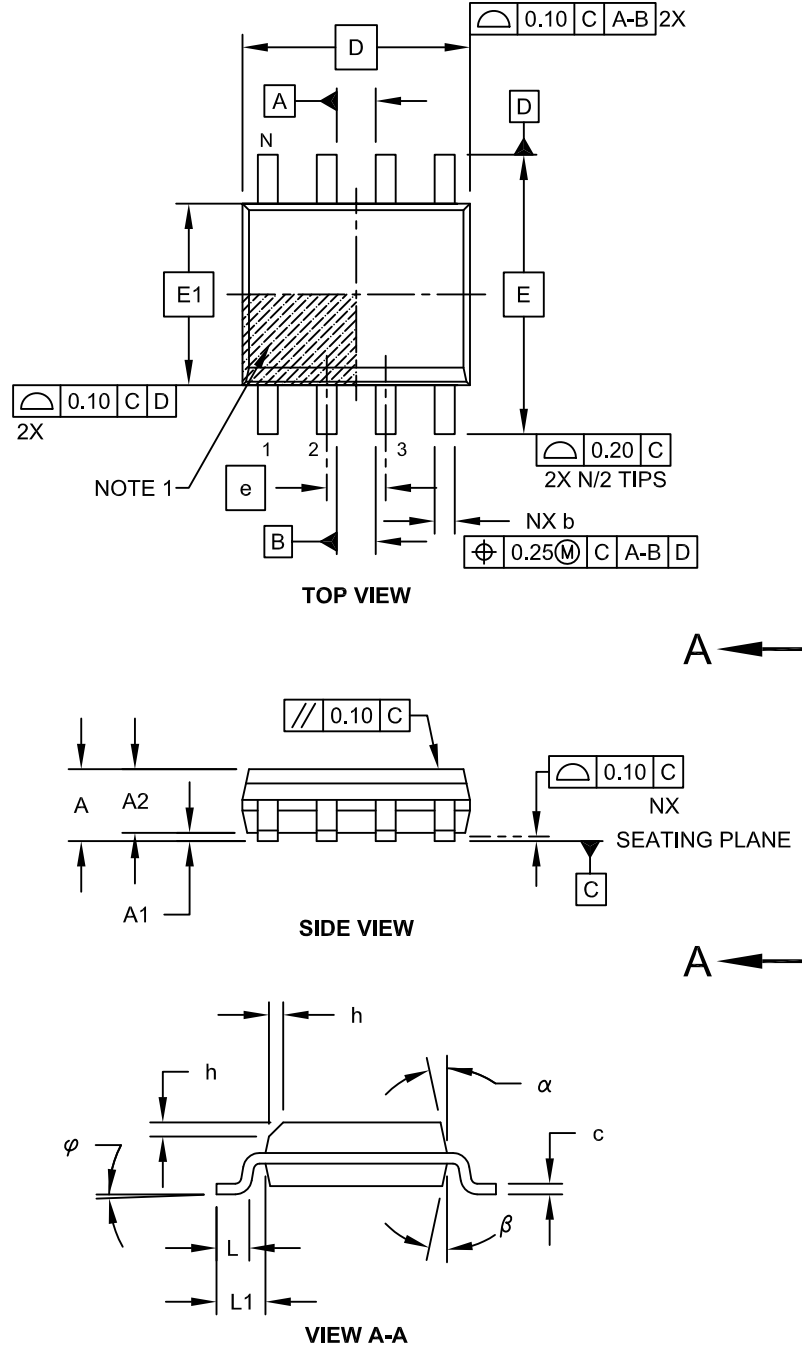

Microchip Technology Drawing No. C04-057C Sheet 1 of 2

# 24AA256/24LC256/24FC256

## 8-Lead Plastic Small Outline (SN) - Narrow, 3.90 mm Body [SOIC]

**Note:** For the most current package drawings, please see the Microchip Packaging Specification located at <http://www.microchip.com/packaging>

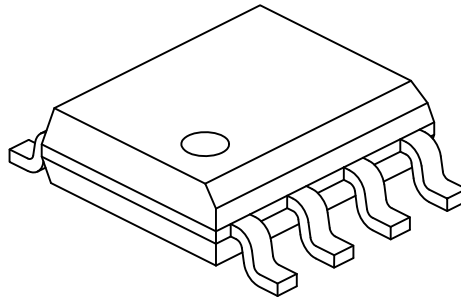

| Dimension Limits         | Units     | MILLIMETERS |     |      |
|--------------------------|-----------|-------------|-----|------|
|                          |           | MIN         | NOM | MAX  |
| Number of Pins           | N         | 8           |     |      |
| Pitch                    | e         | 1.27 BSC    |     |      |
| Overall Height           | A         | -           | -   | 1.75 |
| Molded Package Thickness | A2        | 1.25        | -   | -    |
| Standoff §               | A1        | 0.10        | -   | 0.25 |
| Overall Width            | E         | 6.00 BSC    |     |      |
| Molded Package Width     | E1        | 3.90 BSC    |     |      |
| Overall Length           | D         | 4.90 BSC    |     |      |
| Chamfer (Optional)       | h         | 0.25        | -   | 0.50 |
| Foot Length              | L         | 0.40        | -   | 1.27 |
| Footprint                | L1        | 1.04 REF    |     |      |
| Foot Angle               | $\varphi$ | 0°          | -   | 8°   |
| Lead Thickness           | c         | 0.17        | -   | 0.25 |
| Lead Width               | b         | 0.31        | -   | 0.51 |
| Mold Draft Angle Top     | $\alpha$  | 5°          | -   | 15°  |
| Mold Draft Angle Bottom  | $\beta$   | 5°          | -   | 15°  |

### Notes:

1. Pin 1 visual index feature may vary, but must be located within the hatched area.
2. § Significant Characteristic
3. Dimensions D and E1 do not include mold flash or protrusions. Mold flash or protrusions shall not exceed 0.15mm per side.
4. Dimensioning and tolerancing per ASME Y14.5M

BSC: Basic Dimension. Theoretically exact value shown without tolerances.

REF: Reference Dimension, usually without tolerance, for information purposes only.

Microchip Technology Drawing No. C04-057C Sheet 2 of 2

# 24AA256/24LC256/24FC256

## 8-Lead Plastic Small Outline (SN) – Narrow, 3.90 mm Body [SOIC]

**Note:** For the most current package drawings, please see the Microchip Packaging Specification located at <http://www.microchip.com/packaging>

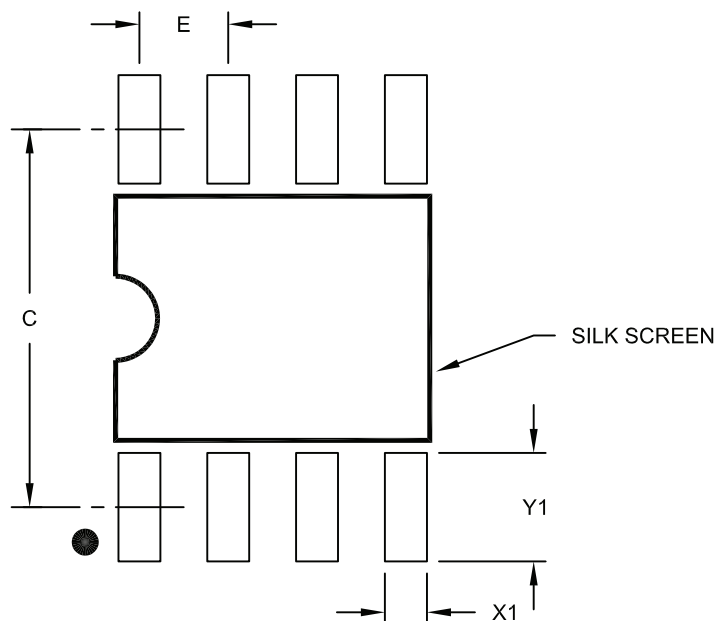

RECOMMENDED LAND PATTERN

| Dimension Limits        | Units | MILLIMETERS |          |      |
|-------------------------|-------|-------------|----------|------|
|                         |       | MIN         | NOM      | MAX  |
| Contact Pitch           | E     |             | 1.27 BSC |      |
| Contact Pad Spacing     | C     |             | 5.40     |      |
| Contact Pad Width (X8)  | X1    |             |          | 0.60 |
| Contact Pad Length (X8) | Y1    |             |          | 1.55 |

**Notes:**

1. Dimensioning and tolerancing per ASME Y14.5M

BSC: Basic Dimension. Theoretically exact value shown without tolerances.

Microchip Technology Drawing No. C04-2057A

# 24AA256/24LC256/24FC256

## 8-Lead Plastic Small Outline (SM) - Medium, 5.28 mm Body [SOIJ]

**Note:** For the most current package drawings, please see the Microchip Packaging Specification located at <http://www.microchip.com/packaging>

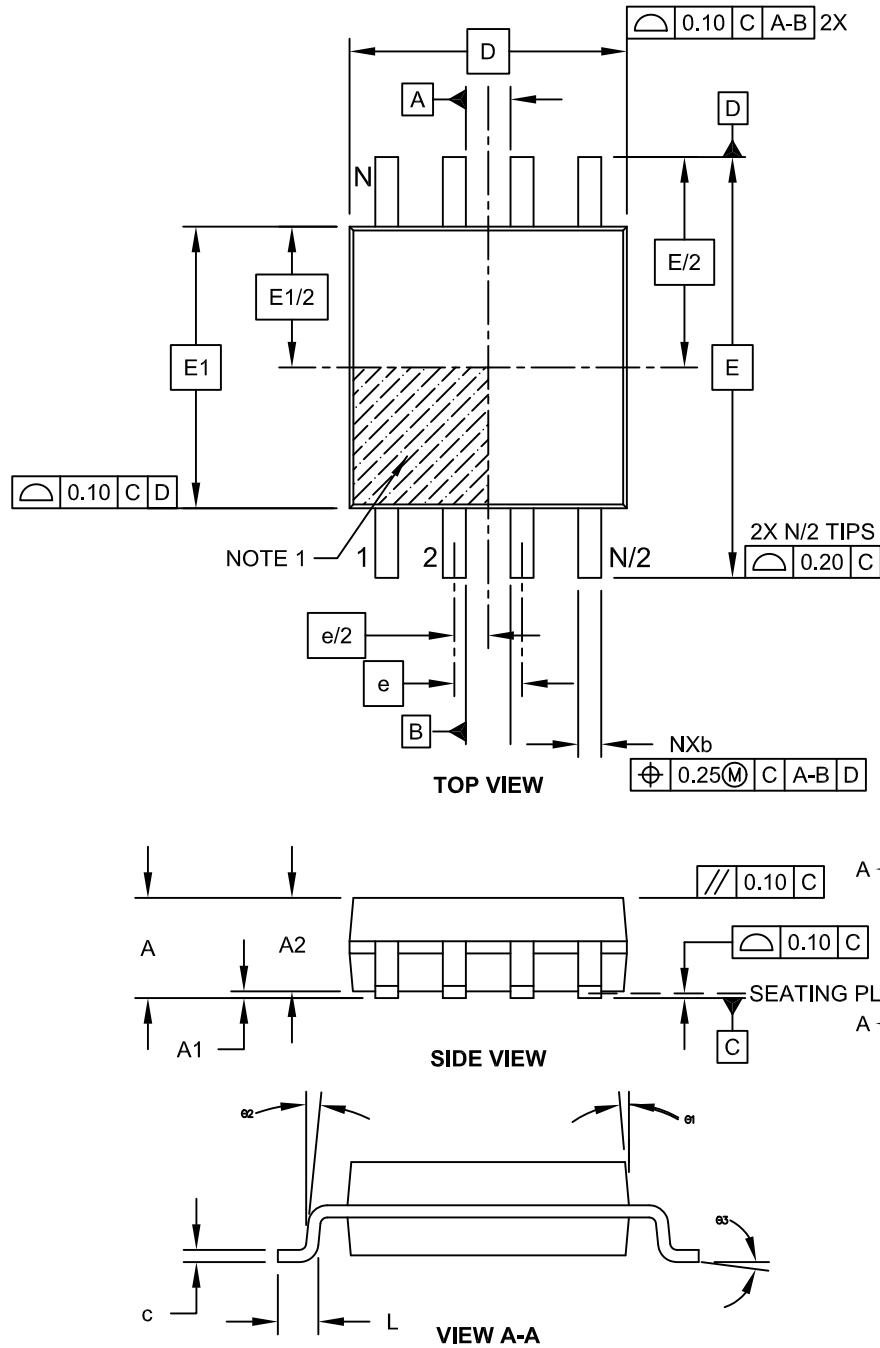

Microchip Technology Drawing C04-056C Sheet 1 of 2

# 24AA256/24LC256/24FC256

## 8-Lead Plastic Small Outline (SM) - Medium, 5.28 mm Body [SOIJ]

**Note:** For the most current package drawings, please see the Microchip Packaging Specification located at <http://www.microchip.com/packaging>

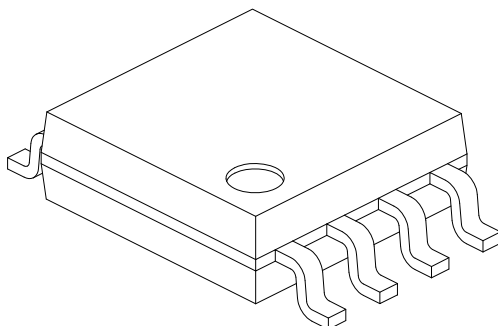

| Dimension Limits         | Units | MILLIMETERS |     |      |
|--------------------------|-------|-------------|-----|------|
|                          |       | MIN         | NOM | MAX  |
| Number of Pins           | N     | 8           |     |      |
| Pitch                    | e     | 1.27 BSC    |     |      |
| Overall Height           | A     | 1.77        | -   | 2.03 |
| Standoff §               | A1    | 0.05        |     | 0.25 |
| Molded Package Thickness | A2    | 1.75        | -   | 1.98 |
| Overall Width            | E     | 7.94 BSC    |     |      |
| Molded Package Width     | E1    | 5.25 BSC    |     |      |
| Overall Length           | D     | 5.26 BSC    |     |      |
| Foot Length              | L     | 0.51        | -   | 0.76 |
| Lead Thickness           | c     | 0.15        | -   | 0.25 |
| Lead Width               | b     | 0.36        | -   | 0.51 |
| Mold Draft Angle         | Ø1    | -           | -   | 15°  |
| Lead Angle               | Ø2    | 0°          | -   | 8°   |
| Foot Angle               | Ø3    | 0°          | -   | 8°   |

**Notes:**

1. SOIJ, JEITA/EIAJ Standard, Formerly called SOIC
2. § Significant Characteristic
3. Dimensions D and E1 do not include mold flash or protrusions. Mold flash or protrusions shall not exceed 0.25mm per side.

Microchip Technology Drawing No. C04-056C Sheet 2 of 2

# 24AA256/24LC256/24FC256

8-Lead Plastic Small Outline (SM) - Medium, 5.28 mm Body [SOIJ]

**Note:** For the most current package drawings, please see the Microchip Packaging Specification located at <http://www.microchip.com/packaging>

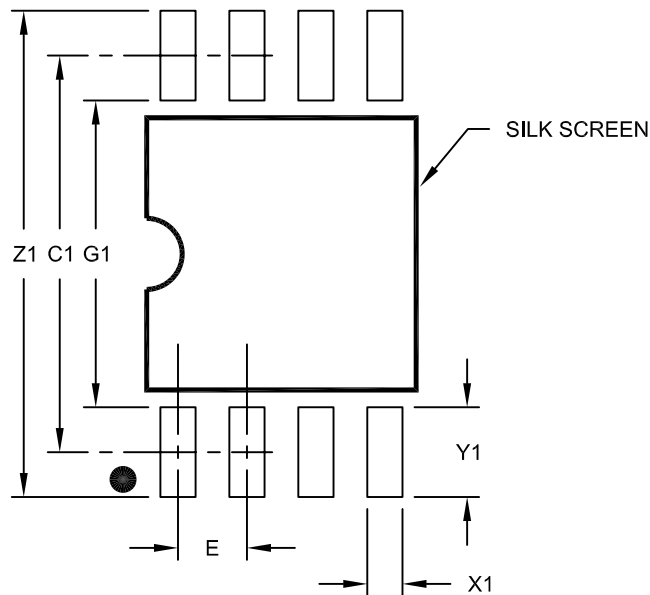

RECOMMENDED LAND PATTERN

| Dimension Limits        | Units | MILLIMETERS |      |      |
|-------------------------|-------|-------------|------|------|
|                         |       | MIN         | NOM  | MAX  |
| Contact Pitch           | E     | 1.27 BSC    |      |      |
| Overall Width           | Z1    |             |      | 9.00 |
| Contact Pad Spacing     | C1    |             | 7.30 |      |
| Contact Pad Width (X8)  | X1    |             |      | 0.65 |
| Contact Pad Length (X8) | Y1    |             |      | 1.70 |
| Distance Between Pads   | G1    | 5.60        |      |      |
| Distance Between Pads   | G     | 0.62        |      |      |

Notes:

1. Dimensioning and tolerancing per ASME Y14.5M

BSC: Basic Dimension. Theoretically exact value shown without tolerances.

Microchip Technology Drawing No. C04-2056C

# 24AA256/24LC256/24FC256

## 8-Lead Plastic Thin Shrink Small Outline (ST) – 4.4 mm Body [TSSOP]

**Note:** For the most current package drawings, please see the Microchip Packaging Specification located at <http://www.microchip.com/packaging>

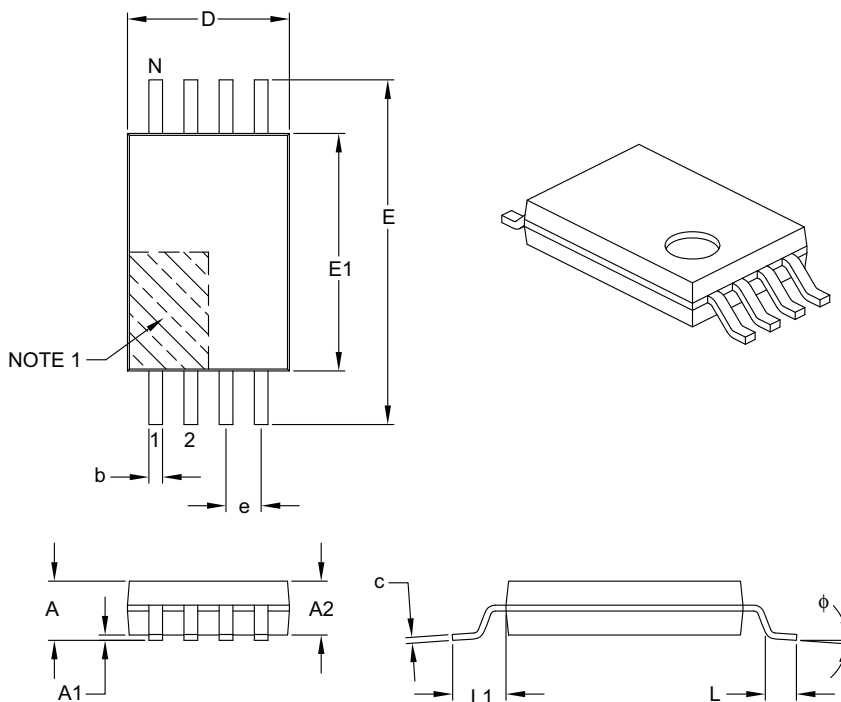

| Dimension Limits         | Units  | MILLIMETERS |      |      |
|--------------------------|--------|-------------|------|------|
|                          |        | MIN         | NOM  | MAX  |
| Number of Pins           | N      | 8           |      |      |
| Pitch                    | e      | 0.65 BSC    |      |      |
| Overall Height           | A      | –           | –    | 1.20 |
| Molded Package Thickness | A2     | 0.80        | 1.00 | 1.05 |
| Standoff                 | A1     | 0.05        | –    | 0.15 |
| Overall Width            | E      | 6.40 BSC    |      |      |
| Molded Package Width     | E1     | 4.30        | 4.40 | 4.50 |
| Molded Package Length    | D      | 2.90        | 3.00 | 3.10 |
| Foot Length              | L      | 0.45        | 0.60 | 0.75 |
| Footprint                | L1     | 1.00 REF    |      |      |
| Foot Angle               | $\phi$ | 0°          | –    | 8°   |
| Lead Thickness           | c      | 0.09        | –    | 0.20 |
| Lead Width               | b      | 0.19        | –    | 0.30 |

**Notes:**

- Pin 1 visual index feature may vary, but must be located within the hatched area.
- Dimensions D and E1 do not include mold flash or protrusions. Mold flash or protrusions shall not exceed 0.15 mm per side.
- Dimensioning and tolerancing per ASME Y14.5M.

BSC: Basic Dimension. Theoretically exact value shown without tolerances.

REF: Reference Dimension, usually without tolerance, for information purposes only.

Microchip Technology Drawing C04-086B

# 24AA256/24LC256/24FC256

8-Lead Plastic Thin Shrink Small Outline (ST) - 4.4 mm Body [TSSOP]

**Note:** For the most current package drawings, please see the Microchip Packaging Specification located at <http://www.microchip.com/packaging>

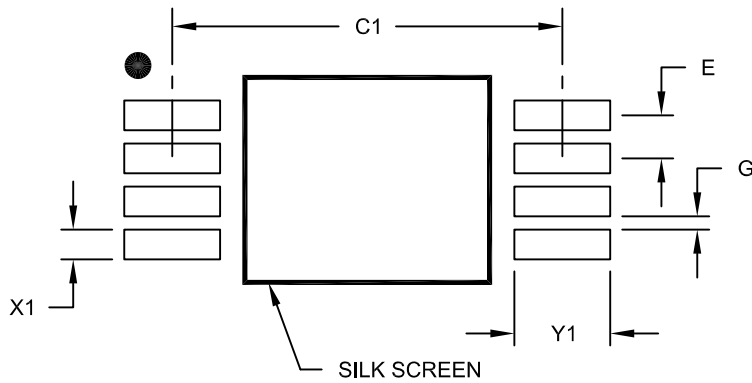

## RECOMMENDED LAND PATTERN

| Dimension Limits        | Units | MILLIMETERS |      |      |
|-------------------------|-------|-------------|------|------|
|                         |       | MIN         | NOM  | MAX  |
| Contact Pitch           | E     | 0.65 BSC    |      |      |
| Contact Pad Spacing     | C1    |             | 5.90 |      |
| Contact Pad Width (X8)  | X1    |             |      | 0.45 |
| Contact Pad Length (X8) | Y1    |             |      | 1.45 |
| Distance Between Pads   | G     | 0.20        |      |      |

**Notes:**

1. Dimensioning and tolerancing per ASME Y14.5M

BSC: Basic Dimension, Theoretically exact value shown without tolerances.

Microchip Technology Drawing No. C04-2086A

# 24AA256/24LC256/24FC256

## 8-Lead Plastic Micro Small Outline Package (MS) [MSOP]

**Note:** For the most current package drawings, please see the Microchip Packaging Specification located at <http://www.microchip.com/packaging>

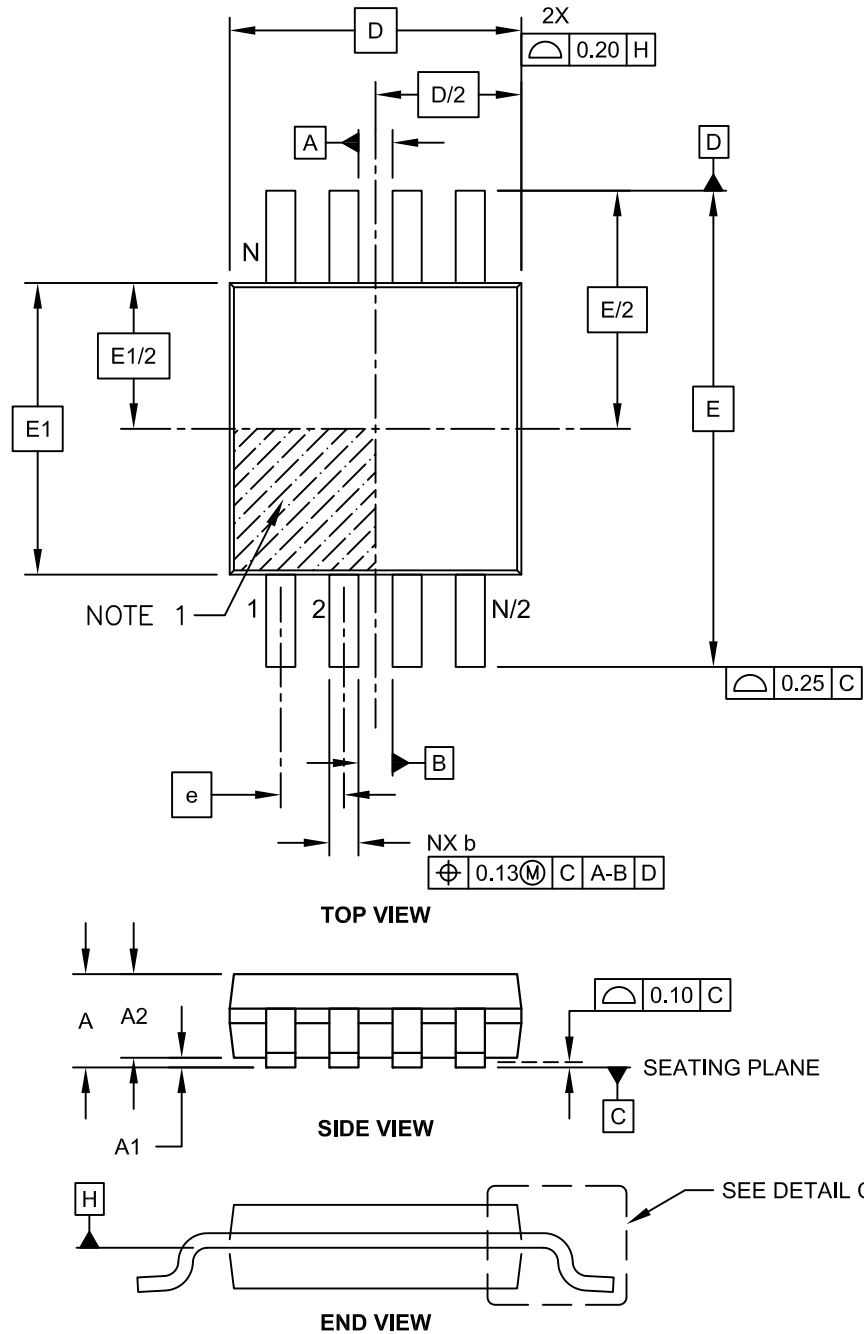

Microchip Technology Drawing C04-111C Sheet 1 of 2

# 24AA256/24LC256/24FC256

## 8-Lead Plastic Micro Small Outline Package (MS) [MSOP]

**Note:** For the most current package drawings, please see the Microchip Packaging Specification located at <http://www.microchip.com/packaging>

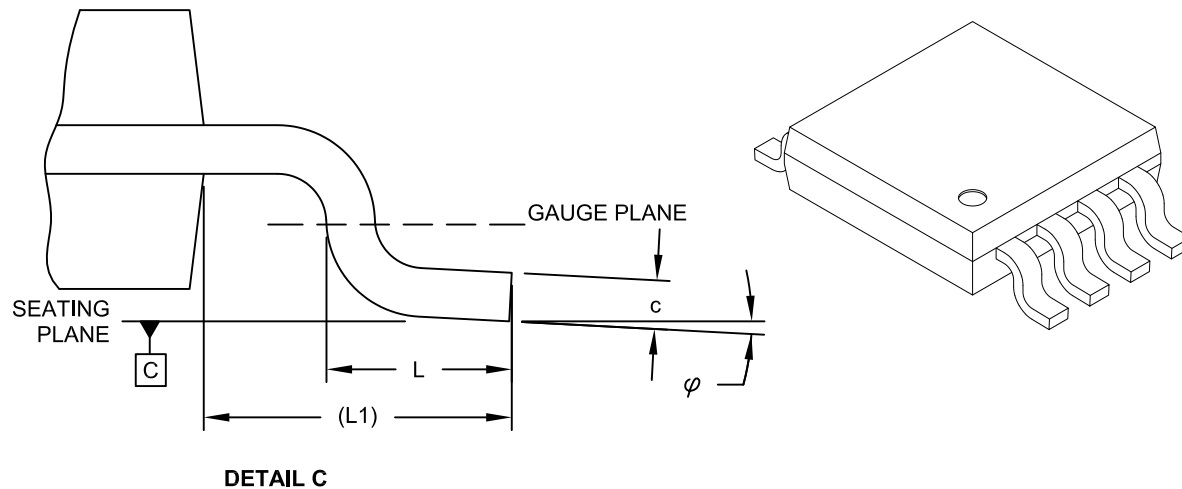

| Dimension Limits         | Units | MILLIMETERS |      |      |
|--------------------------|-------|-------------|------|------|
|                          |       | MIN         | NOM  | MAX  |
| Number of Pins           | N     |             | 8    |      |
| Pitch                    | e     | 0.65 BSC    |      |      |
| Overall Height           | A     | -           | -    | 1.10 |
| Molded Package Thickness | A2    | 0.75        | 0.85 | 0.95 |
| Standoff                 | A1    | 0.00        | -    | 0.15 |
| Overall Width            | E     | 4.90 BSC    |      |      |
| Molded Package Width     | E1    | 3.00 BSC    |      |      |
| Overall Length           | D     | 3.00 BSC    |      |      |
| Foot Length              | L     | 0.40        | 0.60 | 0.80 |
| Footprint                | L1    | 0.95 REF    |      |      |
| Foot Angle               | φ     | 0°          | -    | 8°   |
| Lead Thickness           | c     | 0.08        | -    | 0.23 |
| Lead Width               | b     | 0.22        | -    | 0.40 |

**Notes:**

1. Pin 1 visual index feature may vary, but must be located within the hatched area.
2. Dimensions D and E1 do not include mold flash or protrusions. Mold flash or protrusions shall not exceed 0.15mm per side.
3. Dimensioning and tolerancing per ASME Y14.5M.

BSC: Basic Dimension. Theoretically exact value shown without tolerances.

REF: Reference Dimension, usually without tolerance, for information purposes only.

Microchip Technology Drawing C04-111C Sheet 2 of 2

# 24AA256/24LC256/24FC256

## 8-Lead Plastic Micro Small Outline Package (MS) [MSOP]

**Note:** For the most current package drawings, please see the Microchip Packaging Specification located at <http://www.microchip.com/packaging>

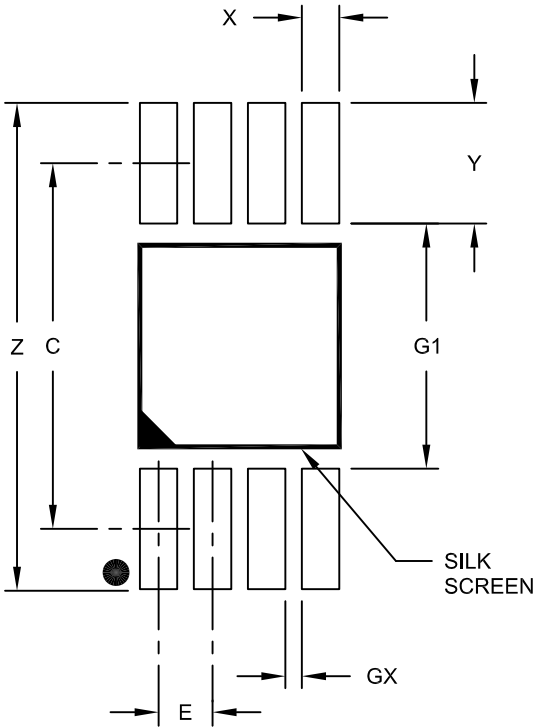

RECOMMENDED LAND PATTERN

| Dimension Limits        | Units | MILLIMETERS |      |      |
|-------------------------|-------|-------------|------|------|
|                         |       | MIN         | NOM  | MAX  |
| Contact Pitch           | E     | 0.65 BSC    |      |      |
| Contact Pad Spacing     | C     |             | 4.40 |      |
| Overall Width           | Z     |             |      | 5.85 |
| Contact Pad Width (X8)  | X1    |             |      | 0.45 |
| Contact Pad Length (X8) | Y1    |             |      | 1.45 |
| Distance Between Pads   | G1    | 2.95        |      |      |
| Distance Between Pads   | GX    | 0.20        |      |      |

Notes:

1. Dimensioning and tolerancing per ASME Y14.5M

BSC: Basic Dimension. Theoretically exact value shown without tolerances.

Microchip Technology Drawing No. C04-2111A

# 24AA256/24LC256/24FC256

## 8-Lead Plastic Dual Flat, No Lead Package (MF) – 6x5 mm Body [DFN-S]

**Note:** For the most current package drawings, please see the Microchip Packaging Specification located at <http://www.microchip.com/packaging>

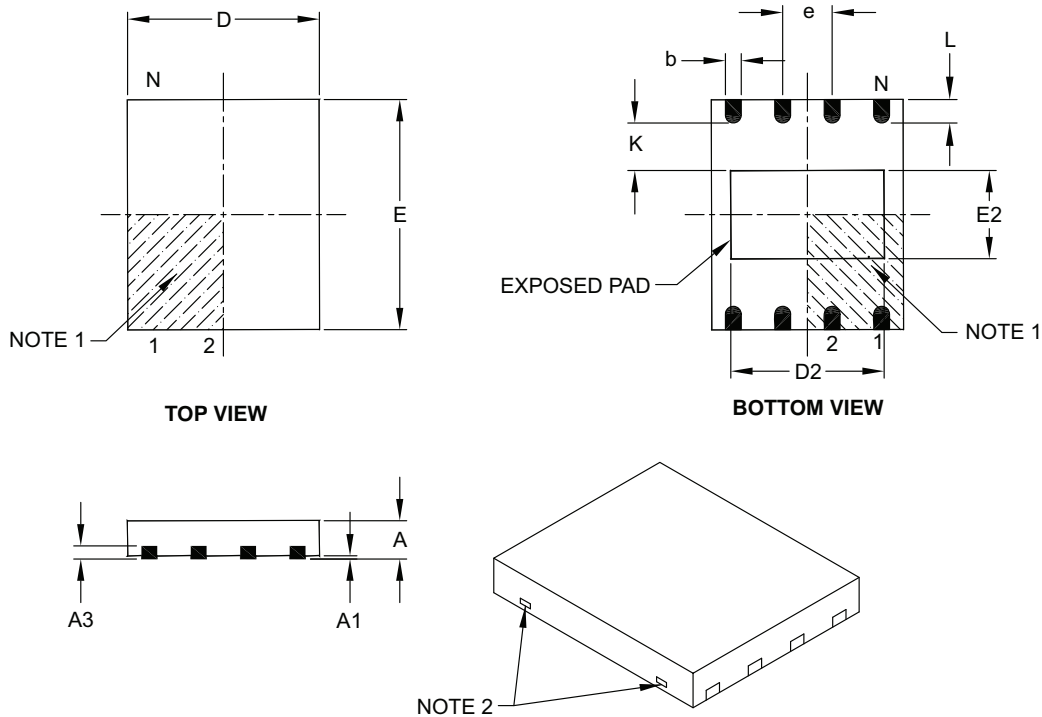

| Dimension Limits       | Units | MILLIMETERS |      |      |
|------------------------|-------|-------------|------|------|
|                        |       | MIN         | NOM  | MAX  |
| Number of Pins         | N     | 8           |      |      |
| Pitch                  | e     | 1.27 BSC    |      |      |
| Overall Height         | A     | 0.80        | 0.85 | 1.00 |
| Standoff               | A1    | 0.00        | 0.01 | 0.05 |
| Contact Thickness      | A3    | 0.20 REF    |      |      |
| Overall Length         | D     | 5.00 BSC    |      |      |
| Overall Width          | E     | 6.00 BSC    |      |      |
| Exposed Pad Length     | D2    | 3.90        | 4.00 | 4.10 |
| Exposed Pad Width      | E2    | 2.20        | 2.30 | 2.40 |
| Contact Width          | b     | 0.35        | 0.40 | 0.48 |
| Contact Length         | L     | 0.50        | 0.60 | 0.75 |
| Contact-to-Exposed Pad | K     | 0.20        | –    | –    |

**Notes:**

- Pin 1 visual index feature may vary, but must be located within the hatched area.
- Package may have one or more exposed tie bars at ends.
- Package is saw singulated.
- Dimensioning and tolerancing per ASME Y14.5M.

BSC: Basic Dimension. Theoretically exact value shown without tolerances.

REF: Reference Dimension, usually without tolerance, for information purposes only.

Microchip Technology Drawing C04-122B

# 24AA256/24LC256/24FC256

8-Lead Plastic Dual Flat, No Lead Package (MF) - 6x5 mm Body [DFN-S]

**Note:** For the most current package drawings, please see the Microchip Packaging Specification located at <http://www.microchip.com/packaging>

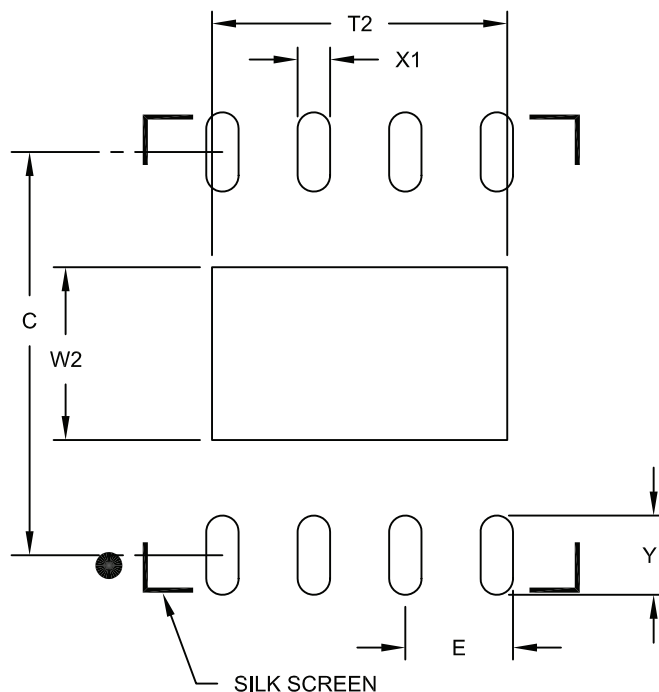

RECOMMENDED LAND PATTERN

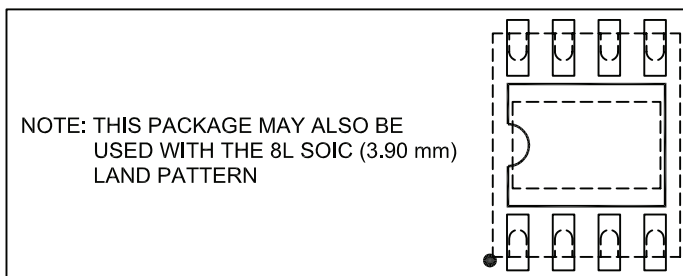

| Dimension Limits           | Units | MILLIMETERS |      |      |
|----------------------------|-------|-------------|------|------|
|                            |       | MIN         | NOM  | MAX  |
| Contact Pitch              | E     | 1.27 BSC    |      |      |
| Optional Center Pad Width  | W2    |             |      | 2.40 |
| Optional Center Pad Length | T2    |             |      | 4.10 |
| Contact Pad Spacing        | C     |             | 5.60 |      |
| Contact Pad Width (X8)     | X1    |             |      | 0.45 |
| Contact Pad Length (X8)    | Y1    |             |      | 1.10 |

**Notes:**

1. Dimensioning and tolerancing per ASME Y14.5M

BSC: Basic Dimension. Theoretically exact value shown without tolerances.

Microchip Technology Drawing No. C04-2122A

# 24AA256/24LC256/24FC256

## 8-Lead Plastic Dual Flat, No Lead Package (MN) – 2x3x0.75mm Body [TDFN]

**Note:** For the most current package drawings, please see the Microchip Packaging Specification located at <http://www.microchip.com/packaging>

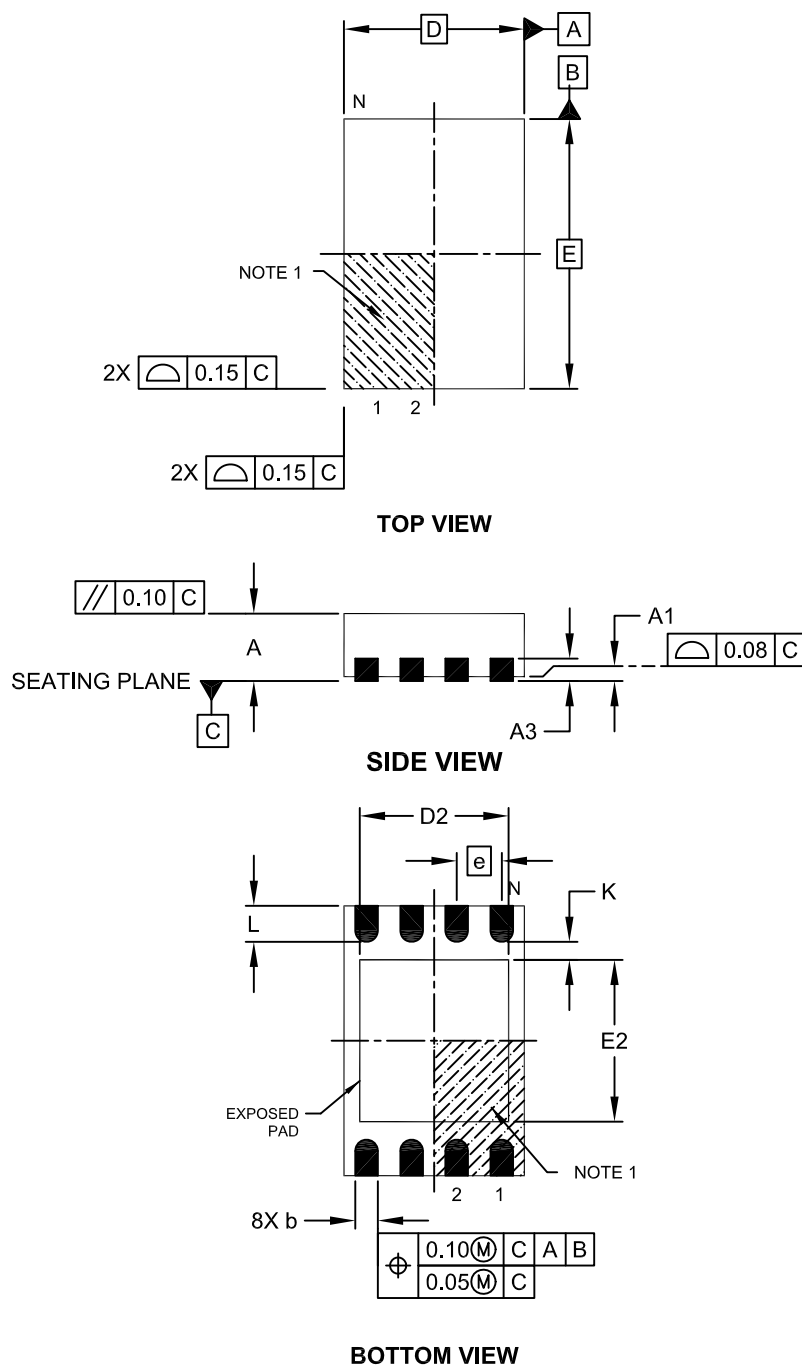

Microchip Technology Drawing No. C04-129C Sheet 1 of 2

# 24AA256/24LC256/24FC256

## 8-Lead Plastic Dual Flat, No Lead Package (MN) – 2x3x0.75mm Body [TDFN]

**Note:** For the most current package drawings, please see the Microchip Packaging Specification located at <http://www.microchip.com/packaging>

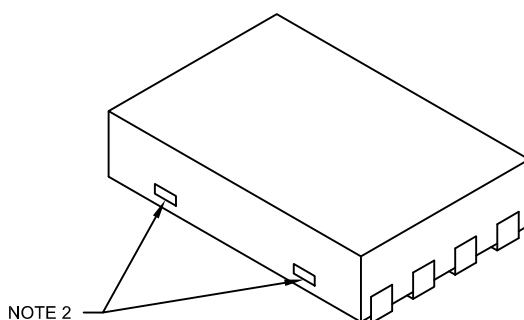

| Dimension Limits       | Units | MILLIMETERS |      |      |
|------------------------|-------|-------------|------|------|
|                        |       | MIN         | NOM  | MAX  |
| Number of Pins         | N     | 8           |      |      |
| Pitch                  | e     | 0.50 BSC    |      |      |
| Overall Height         | A     | 0.70        | 0.75 | 0.80 |
| Standoff               | A1    | 0.00        | 0.02 | 0.05 |
| Contact Thickness      | A3    | 0.20 REF    |      |      |
| Overall Length         | D     | 2.00 BSC    |      |      |
| Overall Width          | E     | 3.00 BSC    |      |      |
| Exposed Pad Length     | D2    | 1.20        | -    | 1.60 |
| Exposed Pad Width      | E2    | 1.20        | -    | 1.60 |
| Contact Width          | b     | 0.20        | 0.25 | 0.30 |
| Contact Length         | L     | 0.25        | 0.30 | 0.45 |
| Contact-to-Exposed Pad | K     | 0.20        | -    | -    |

### Notes:

1. Pin 1 visual index feature may vary, but must be located within the hatched area.
2. Package may have one or more exposed tie bars at ends.
3. Package is saw singulated
4. Dimensioning and tolerancing per ASME Y14.5M

BSC: Basic Dimension. Theoretically exact value shown without tolerances.

REF: Reference Dimension, usually without tolerance, for information purposes only.

Microchip Technology Drawing No. C04-129C Sheet 2 of 2

# 24AA256/24LC256/24FC256

## 8-Lead Plastic Dual Flat, No Lead Package (MN) – 2x3x0.75 mm Body [TDFN]

**Note:** For the most current package drawings, please see the Microchip Packaging Specification located at <http://www.microchip.com/packaging>

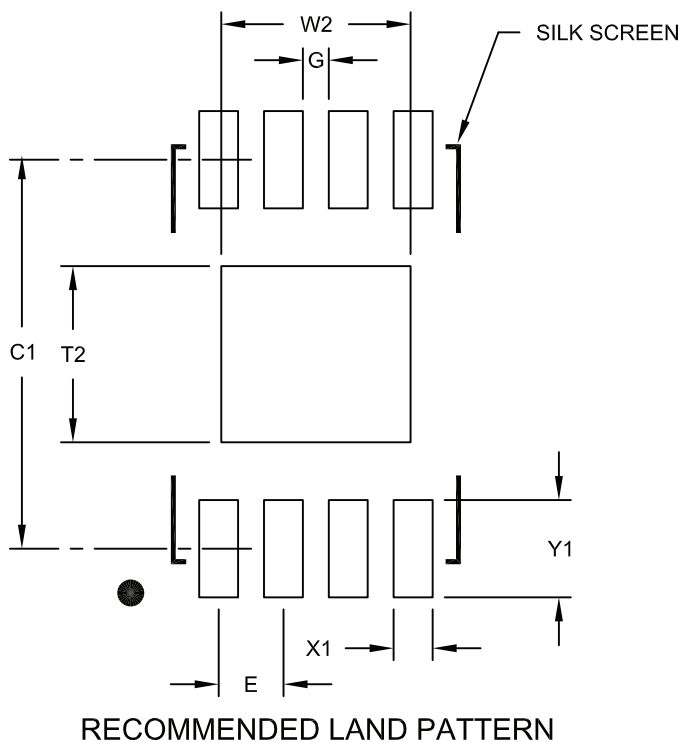

| Dimension                  | Units | MILLIMETERS |      |      |
|----------------------------|-------|-------------|------|------|
|                            |       | MIN         | NOM  | MAX  |
| Dimension Limits           |       |             |      |      |
| Contact Pitch              | E     | 0.50 BSC    |      |      |
| Optional Center Pad Width  | W2    |             |      | 1.46 |
| Optional Center Pad Length | T2    |             |      | 1.36 |
| Contact Pad Spacing        | C1    |             | 3.00 |      |
| Contact Pad Width (X8)     | X1    |             |      | 0.30 |
| Contact Pad Length (X8)    | Y1    |             |      | 0.75 |
| Distance Between Pads      | G     | 0.20        |      |      |

**Notes:**

1. Dimensioning and tolerancing per ASME Y14.5M

BSC: Basic Dimension. Theoretically exact value shown without tolerances.

Microchip Technology Drawing No. C04-2129A

# 24AA256/24LC256/24FC256

## 8-Lead Chip Scale Package (CS) - [CSP]

**Note:** For the most current package drawings, please see the Microchip Packaging Specification located at <http://www.microchip.com/packaging>

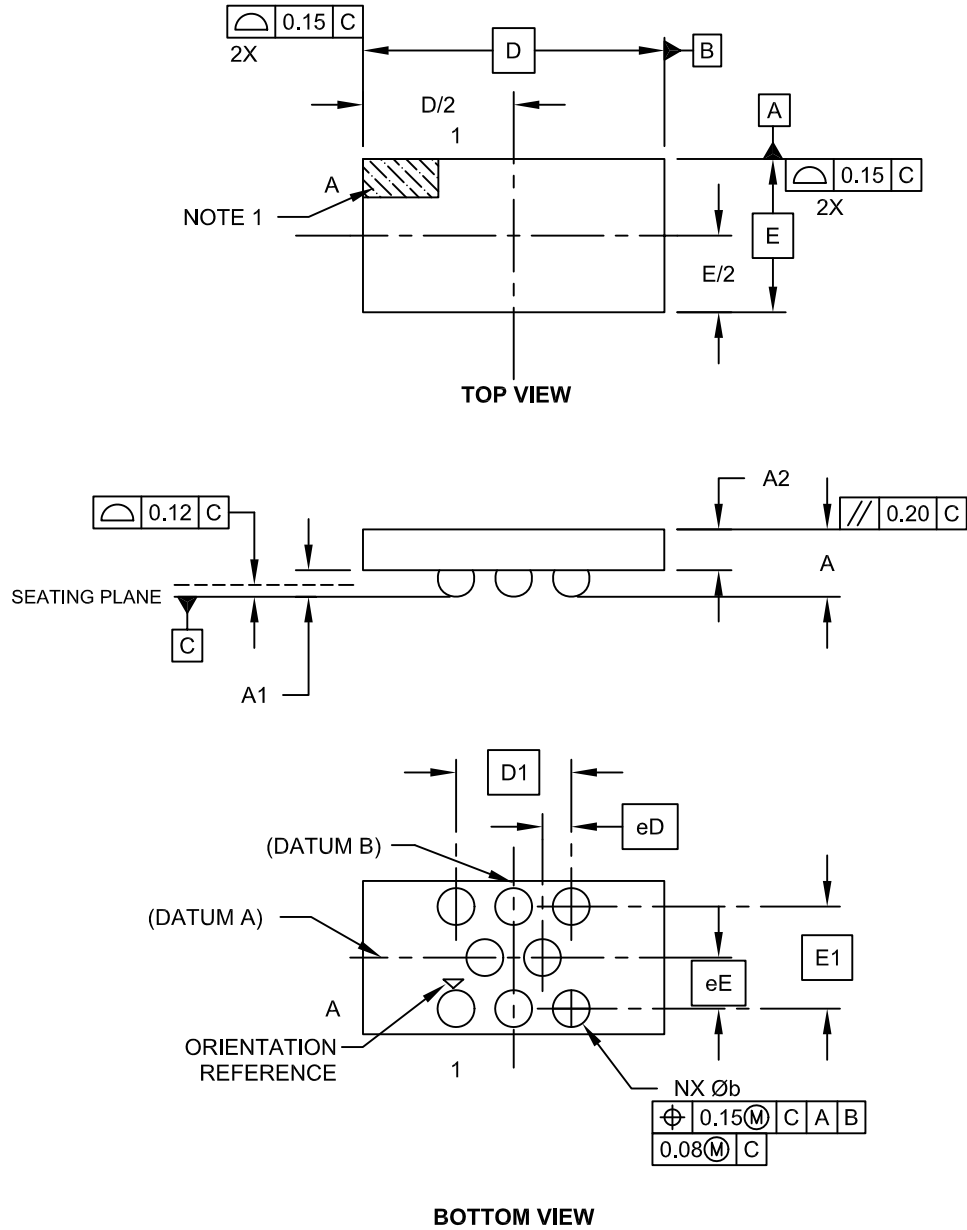

Microchip Technology Drawing C04-6001C Sheet 1 of 2

# 24AA256/24LC256/24FC256

## 8-Lead Chip Scale Package (CS) - [CSP]

**Note:** For the most current package drawings, please see the Microchip Packaging Specification located at <http://www.microchip.com/packaging>

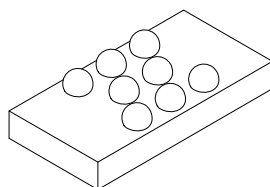

| Dimension Limits        | Units | MILLIMETERS |      |      |
|-------------------------|-------|-------------|------|------|
|                         |       | MIN         | NOM  | MAX  |
| Number of Contacts      | N     |             | 8    |      |
| Overall Grid X-Pitch    | E1    | 0.886 BSC   |      |      |
| Overall Grid Y-Pitch    | D1    | 1.00 BSC    |      |      |
| Adjacent Column X-Pitch | eE    | 0.443 BSC   |      |      |
| Adjacent Row Y-Pitch    | eD    | 0.25 BSC    |      |      |
| Overall Height          | A     | 0.53        | 0.59 | 0.64 |
| Die Height              | A2    | 0.33        | 0.36 | 0.38 |
| Bump Height             | A1    | 0.20        | 0.23 | 0.26 |
| Overall Width           | E     | NOTE 4      |      |      |
| Overall Length          | D     | NOTE 4      |      |      |
| Ball Diameter           | b     | 0.30        | 0.32 | 0.34 |

**Notes:**

1. Orientation reference feature may vary, but must be located within the hatched area.
2. Package is saw singulated.
3. Dimensioning and tolerancing per ASME Y14.5M.  
BSC: Basic Dimension. Theoretically exact value shown without tolerances.  
REF: Reference Dimension, usually without tolerance, for information purposes only.
4. Package size varies with specific devices. Please contact your local Microchip representative for specific details

Microchip Technology Drawing C04-6001C Sheet 2 of 2

# 24AA256/24LC256/24FC256

## 8-Lead Chip Scale Package (CS) - [CSP]

**Note:** For the most current package drawings, please see the Microchip Packaging Specification located at <http://www.microchip.com/packaging>

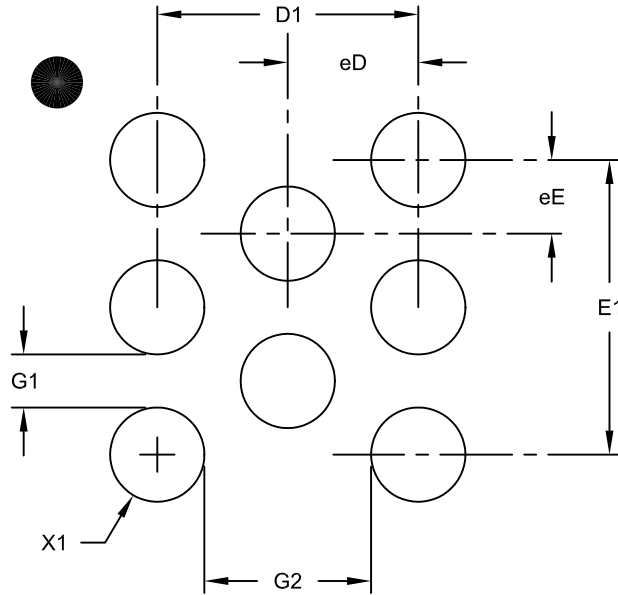

RECOMMENDED LAND PATTERN

| Dimension Limits          | Units | MILLIMETERS |       |      |
|---------------------------|-------|-------------|-------|------|
|                           |       | MIN         | NOM   | MAX  |
| Number of Contacts        | N     | 8           |       |      |
| Contact Pitch Y           | eE    |             | 0.25  |      |
| Contact Pitch X           | eD    |             | 0.443 |      |
| Contact Pad Spacing       | E1    |             | 1.00  |      |
| Contact Pad Spacing       | D1    |             | 0.886 |      |
| Contact Pad Diameter (X8) | X1    |             |       | 0.32 |
| Distance Between Pads     | G1    | 0.18        |       |      |
| Distance Between Pads     | G2    | 0.56        |       |      |

Notes:

1. Dimensioning and tolerancing per ASME Y14.5M

BSC: Basic Dimension. Theoretically exact value shown without tolerances.

Microchip Technology Drawing No. C04-8001A