

A. Package content

- Controller X 1, CD x 1, Warranty card X 1, Installation Guide X 1
- Accessory kit X 1 (Screw X 4, Spacer X 4, 1N4004 X 4), Wiring sticker x 1

B. Installation

- Physical Dimension: 200 x 114 x 27 (mm)
- Recommended: Cable with shielded, Linear DC power supply, Network cable.
- Specifications
 - Voltage range: 9~24 VDC
 - Controller Power Consumption: 300mA (Exclude external device power consumption)
 - Power recommend: 2A (Includes relay expansion module and an external reader device power consumption)
 - Please do not exceed 300mA for external wiegand reader
 - Max distance for wiegand is 80M

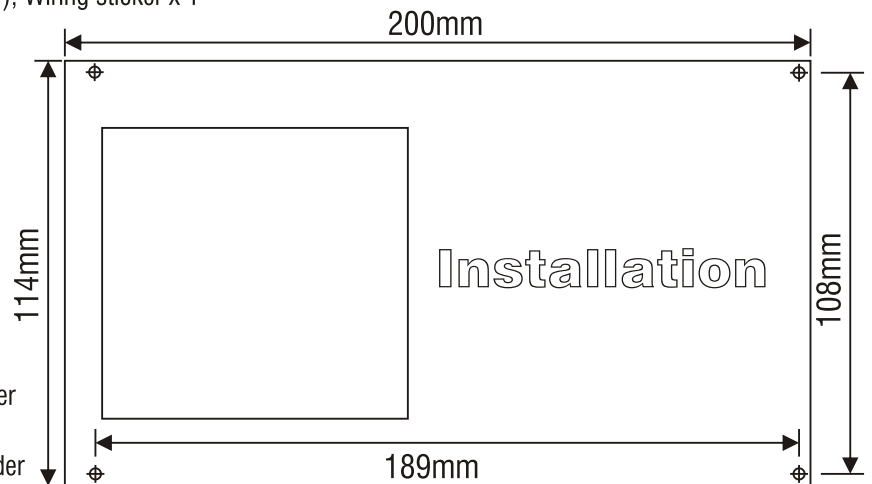

■ Notice

- Do not connect other cables to the power unit except power contacts.
- Do not apply any unverified power supply to the unit. (Might cause hardware damage and system unstable)

■ Optional

- Chassis Size 255 x 290 x 78 (mm)
- Relay Expansion Module

C. Structure

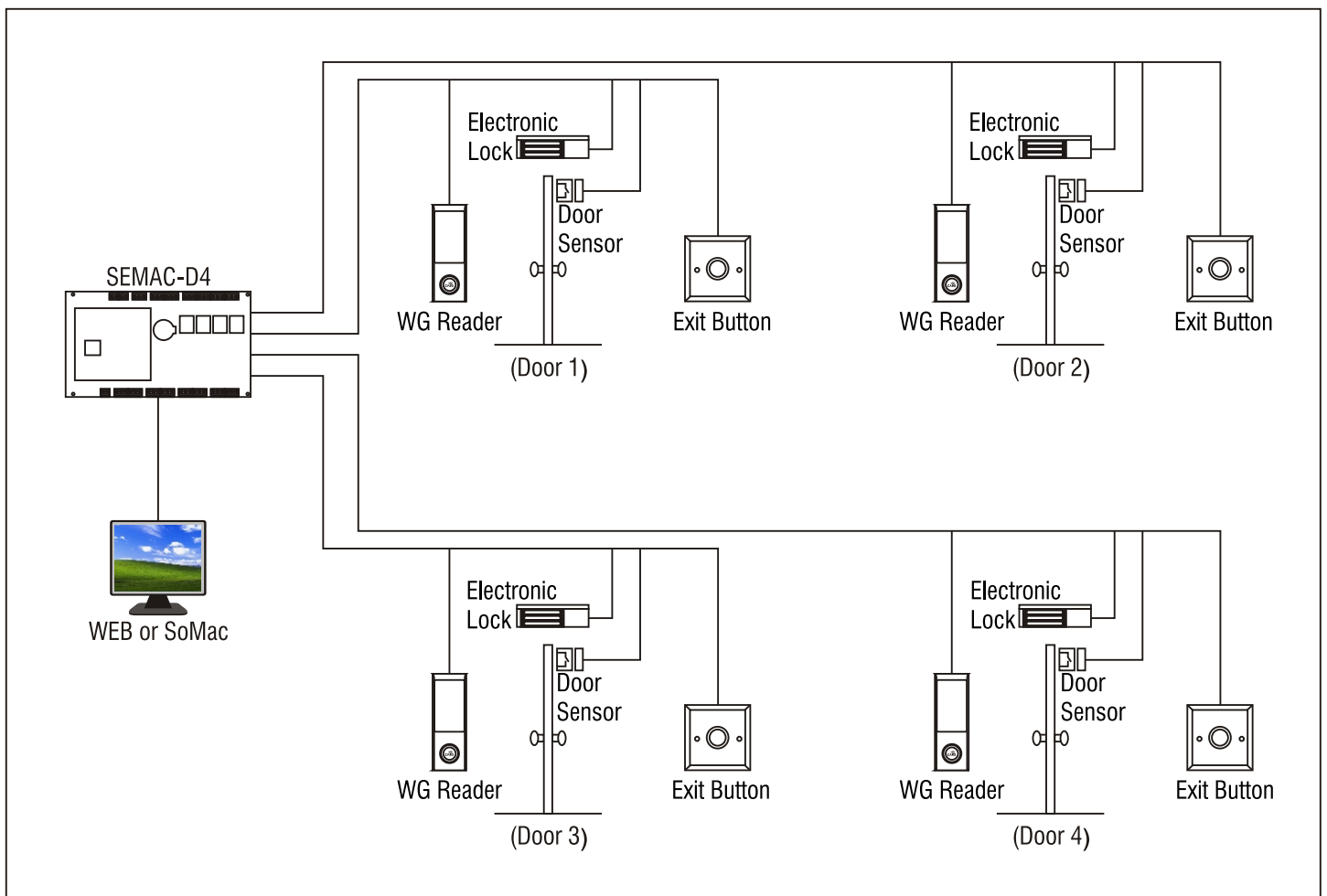

Door Relay Connection

Fail Safe Lock

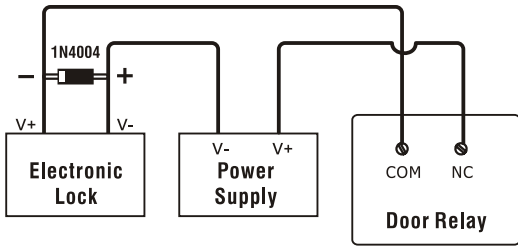

Fail Security Lock

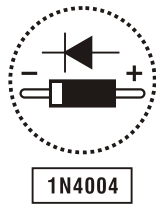
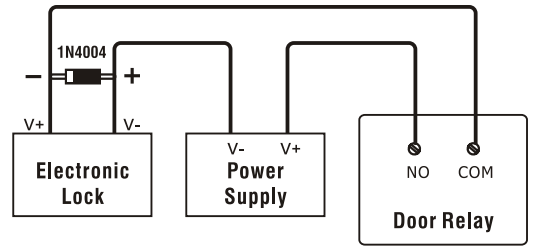

D. Wiring Diagram

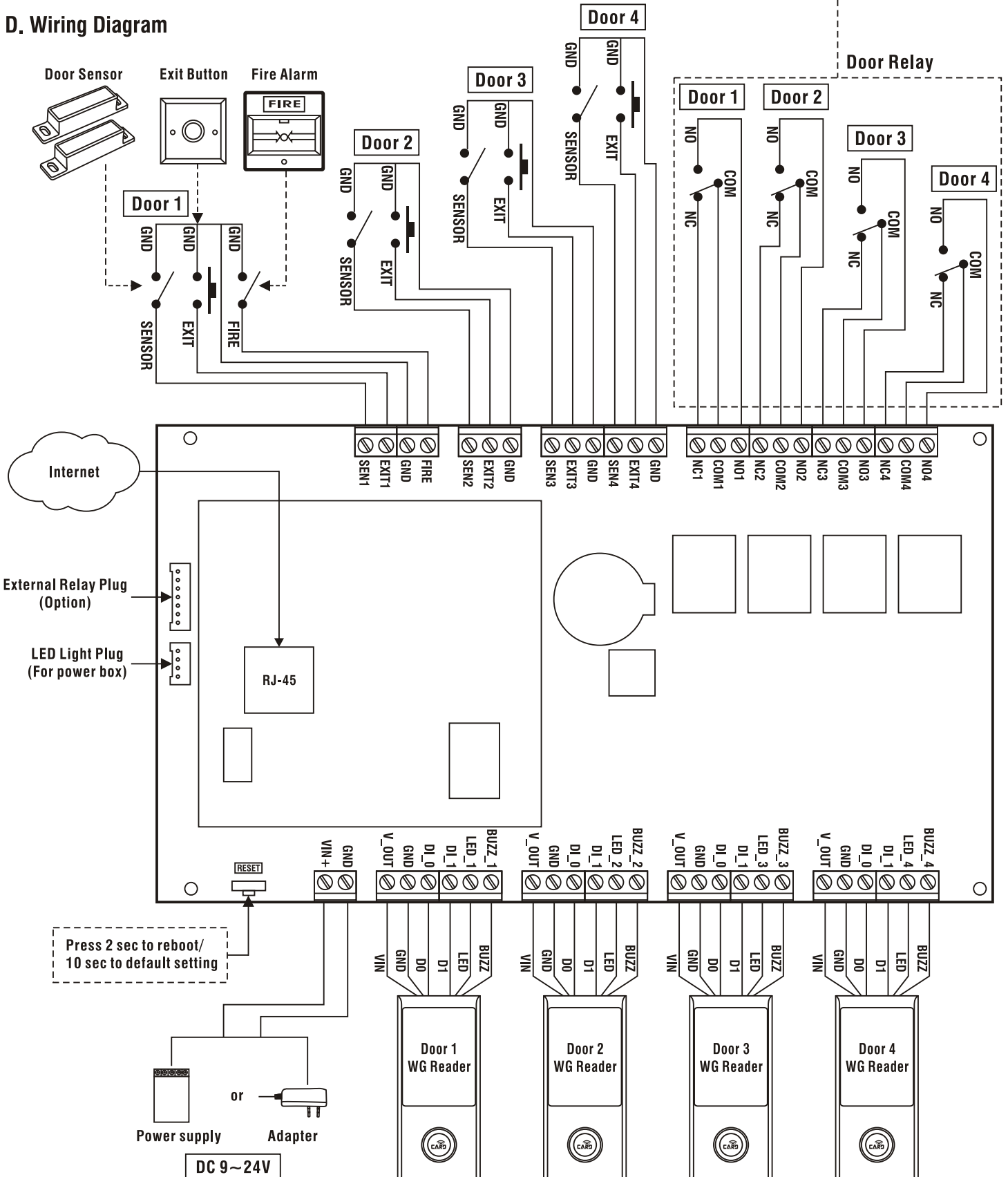

SEMAC-D4

WEB Configuration Manual

【Contents】

WEB Configuration	1
Logon WEB.....	1
Premise.....	1
WEB IE Browser.....	1
Main Window (Terminal Status)	2
Illustration of Terminal Status Screen.....	3
User Administration	4
Log/Report.....	4
Illustration of Access Log.....	5
Auto Refresh Log.....	6
View User List.....	6
Illustration of User List.....	7
Modify User Record.....	8
Modify User List in “View User List”.....	9
Add User.....	10
Illustration of Add New User.....	11
Terminal	12
Terminal Status.....	12
Illustration of Terminal Status.....	13
Terminal Setup.....	14
Illustration of Terminal Configuration.....	15
Password Setup.....	17
Illustration of WEB Logon Setting/Entrance Password.....	18
System Log.....	20
Illustration of System Log.....	20
Clock Setup.....	21
Illustration of System Clock Setup.....	21
Access Control	22
Time Set.....	22
Illustration of Time Set.....	22
Time Zone Setup.....	23
Illustration of Time Zone List.....	23
Illustration of Time Zone Information.....	24
Group List.....	25

Illustration of Group List.....	25
Illustration of Group Information.....	26
Holiday Setup.....	27
Illustration of Holiday Setup.....	27
Door Setup.....	28
Illustration of Door Setting.....	29
Illustrations of Door 1 Setting in Door Setup.....	32
Remote Control.....	35
Illustrations of Door Status Monitoring/Security Bypass.....	36
Event Handle.....	37
Illustration of Event Handle.....	38
Multi Badge Group.....	41
Illustration of Multi Badge Group.....	41
Tools	42
IP Camera.....	42
Illustration of IP Camera.....	42
Backup.....	43
Restore.....	43
Reboot.....	44
Illustration of Reboot.....	44
Upgrade Firmware.....	44
Illustration of Upgrade Firmware.....	44
Reset.....	45
Illustration of Reset.....	45

— WEB Configuration —

SEMAC-D4 WEB Configuration

◆ Logon WEB

SEMAC-D4 is with built-in HTTP server for using WEB IE Browser to connect SEMAC-D4 and execute the settings of SEMAC-D4.

◆ Premise

Please make sure the following points before your SEMAC-D4 settings:

- Your PC computer may build up a physical connection with SEMAC-D4, meanwhile, both of your computer and the SEMAC-D4 are within the same Network Segment.
- SEMAC-D4 has been installed and with power.
- Should the default IP address of SEMAC-D4 (192.168.0.66) has been occupied by other devices, you have to shut down all the other devices until the setting completed. Then a new IP address will be distributed to the SEMAC-D4.

◆ WEB IE Browser

- 1 · Start the WEB IE Browser first.
- 2 · Enter the <http://> and the IP address of SEMAC-D4 in the address bar. For example, enter the default IP address of SEMAC-D4: <http://192.168.0.66>.

Communication failure:

When no feedback from the SEMAC-D4, please check as below:

- Is the SEMAC-D4 installed properly, the local area network (LAN) connected well or the power connected fine? Try to use the “ping” command to test the communication status of SEMAC-D4 IP address by the following steps:
 - Open a MS-DOS window, or a command window;
 - Input your command: ping 192.168.0.66,
For example : C:\user\tank>ping 192.168.0.66If no any response, it indicated abnormal connection or the PC computer IP address in conflict or not match with SEMAC-D4 IP address (referring to next paragraph) .
- If a PC computer with a Static IP/Fixed IP, the IP range should be defined between 192.168.0.1~ 192.168.0.65 or 192.168.0.67~192.168.0.254. So the PC computer IP may be compatible with the default IP address of SEMAC-D4, 192.168.0.66. Moreover, the Subnet Mask should be as 255.255.255.0 ◦
- To make sure both your PC computer and the SEMAC-D4 in the same Network Segment.

➤ Main Window (Terminal Status)

When installation completed and well connected with SEMAC-D4, the “Terminal Status” window will be pop-up. It will show after the following connection frequently as following illustration:

TERMINAL STATUS

Product Name :	SEMAC-D4(20000)
Serial No. :	036fde(113822)
Firmware Version :	1.00.00,Dec 23 2013(HW1.1)
System Time :	02/05/2014 17:28:38
Terminal ID(MAC Address) :	1(00:0e:e3:03:6f:de)
IP Address :	192.168.2.68
Subnet mask :	255.255.255.0
Default Gateway :	192.168.2.1
Primary DNS :	168.95.1.1
Listen Port/Software IP(status) :	2000/0.0.0.0(Offline)
Web Management Port :	68
Registered User :	0
Available User Capacity :	20000
Access/System Log Count :	0/8
Reader Type :	WG34
Anti-Pass-Back(Tolerance Timer) :	Disabled(0)
Anti-Duress :	Disabled
Next SEMAC(status) :	0.0.0.0(Offline)

◆ Illustration of Terminal Status Screen

Browse the Function Bar left side :

▶ User Administration	
Log/Report	Switch to the “Access Log” screen to check, search, export log reports
Auto Refresh Log	Press the button to refresh system to get new logs
View User List	Switch to the “User List” screen to Search/Modify/Delete/Deactivate/Activate user data
Add User	Switch to the “User Record” screen and input user data on the”Add New User ”screen
▶ Terminal	
Terminal Status	Switch to the “Terminal Status” screen (Main Window)
Terminal Setup	Switch to the “Terminal Configuration” screen to input data
Password Setup	Switch to the “WEB Logon Setting” and “Entrance Password” screen.
System Log	Switch to the “System Log” screen.
Clock Setup	Switch to the “System Clock Setup” screen.
▶ Access Control	
Time Set	Switch to the “Time Set” screen.
Time Zone Setup	Switch to the “Time Zone List” screen.
Group List	Switch to the “Group List” screen.
Holiday Setup	Switch to the “Holiday Setup” screen.
Door Setup	Switch to the “Door Setting” screen.
Remote Control	Switch to the “Door Status Monitoring” and “Security Bypass” screen.
Event Handle	Switch to the “Event Handle” screen.
Multi Badge Group	Switch to the “Multi Badge Group” screen.
▶ Tools	
IP Camera	Switch to the “IP Camera Configuration“ screen.
Backup	Switch to Backup screen
Restore	Switch to Restore screen
Reboot	Switch to the “Reboot System“ screen.
Upgrade Firmware	Switch to the “Firmware Upgrade“ screen.
Reset	Switch to the “Reset“ screen.
▶ Button	
Refresh	Refresh the WEB Status.

➤ User Administration

◆ Log/Report

Select "Access Control" on the Main Window, you'll see the "Access Log/Query and Export" screen as the following picture:

Access Log/Query and Export

No.	User ID	User Name	Date	Time	IN/OUT	Door	Note.
-----	---------	-----------	------	------	--------	------	-------

No Log Data

Query and Export

Type <input checked="" type="radio"/> user <input type="radio"/> event	Selection <input checked="" type="radio"/> Single <input type="radio"/> All	Start Date <input type="text" value="2014/02/06"/>	End Date <input type="text" value="2014/02/06"/>
User ID <input type="text"/>	Card No.(DEC) <input type="text"/>		
Export Type <input checked="" type="radio"/> Txt <input type="radio"/> Xls	<input type="button" value="Search"/>	<input type="button" value="Export"/>	

SEMA

◆ Illustration of Access Log

▶ Query (BY)	
Type	By User or Event
Selection	Single or All
Start / End Date	From – To Date period input
User ID	Input User ID or Card No. (in Decimal format)
Export Type	Text (txt) or Excel (xls) format
▶ Access Records Illustration by Columns	
No.	Serial Number
User ID	A system User ID assigned for the user to access door(s). Click the “User ID” to enter the page of “User Record” and “Modify User Record”. ※ The figure in the parentheses () after the “User ID” is indicated the user’s Bypass TZ level as 1~10
User Name	User name has registered to the current system
Date	A date period allowed user(s) to access door(s)
Time	A Time allowed for the User to get IN/OUT.
IN/OUT	4 Door/1 Way: IN : Open the door (1~4) by punching card at the outside of door reader to get IN records OUT : Open the door (1~4) by pressing push button inside of a door to get OUT records ※ The figure in the parentheses () after the “IN/OUT” record indicated APB (Anti Pass Back) level.
Door No.	Indicating the Door Number controlled by SEMAC-D4.
Note	Show up the relative IN/OUT records automatically as Anti-Duress, Fire Alarm.....etc.
the First Page	Back to the 1st IN/OUT records page.
the Former10 pages	Forwarding 10 pages from the current IN/OUT records page.
1 2 3...N page	Change to any IN/OUT records page assigned.
the Latter 10 pages	Backwards 10 pages from the current IN/OUT records page.
the Last Page	Fly to the last IN/OUT records page directly.

◆ Auto Refresh Log

Select “Auto Refresh Log” on the Main Window, there’ll be “Auto Refresh Log” screen as the following picture:

Auto Refresh Log Wed Feb 05 2014 17:52:31 GMT+0800 (台北標準時間)

No.	User ID	User Name	Date	Time	IN/OUT Door	Note.
-----	---------	-----------	------	------	-------------	-------

◆ View User List

Select “View User List” on the Main Window, you’ll see the “User List” screen as the following picture:

User List

Search User : By User ID By Card No.(DEC) By User Name

*Reg Type: F(Fingerprint) , P(Password) , C(Card)

No.	User ID	User Name	User Type	Active	F	P	C	Bypass Level
<input type="checkbox"/> 1.	115	Katherine	Normal	<input checked="" type="radio"/>	<input type="radio"/>	<input type="radio"/>	<input checked="" type="radio"/>	1

Total 1 User(s) << End of List... >>

Activate, Deactivate or Delete SELECTED Employee

◆ Illustration of User List

▶ Search User By	
By “User ID”	Select “User ID”and Enter your “User ID”in the textbox to search.
By “Card No.”(DEC)	Select “Card No.”and Enter your“Card No.”in the textbox to search.
By “User Name”	Select “User Name.”and Enter your“User Name”in the textbox to search.
Click “GO” Button	Start to search.
Steps :	
1、Enter your “User ID”, “Card No.” or “User Name” in the “blank textbox”	
2、Click button “GO” to search.	
▶ User List	
No.	Serial Number. Tick the box before the “Serial Number” and Click the button of “Activate” , “Deactivate” or “Delete” to manage the authorization of “Activate” , “Deactivate” or “Delete” for selected users, multi-selection is allowed.
User ID	User’s ID. Click the “User ID” to enter the “Modify User Record” page.
User Name	Display User Name in the system.
User Type	Types of the User. Whenever the “User Type” is set up in the screen of “Modify User Record”, this page will display Normal User, Super User, Visitor, Guard Touring and Defense Card according to the setup.
Active	Display the user’s authorization status. Green Light indicated the user’s door access authority is being activated, otherwise it is not activated.
P	When the user’s Personal Password registered, this column will be with Green Light.
C	When the user’s card registered, this column will be with Green Light.
Bypass Level	Display the user’s Time Zone level of Bypass from L1~L10.
the First Page	Back to the 1st page of “User List”.
the Former10 pages	Forwarding 10 pages from the current “User List” page.
1 2 3...N page	Change to any “User List” page assigned.
the Latter 10 pages	Backwards 10 pages from the current “User List” page.
the Last Page	Fly to the last “User List” page directly.
▶ Button	
Activate	Activate the User’s authorization.
Deactivate	Deactivate the User’s authorization.
Delete	Delete the User’s information registered.

◆ Modify User Record

Select "Modify User Record" on the Main Window, you'll see the " User Record" screen as following picture:

User Record
Modify User Record

User ID : (1 ~ 20000)
Card No. : (DEC)
Name : (Max 31 chars.)
Expire Date Check : Disable Enable
From (Y) (M) (D) (H) (M)
To (Y) (M) (D) (H) (M)
Status : Activate Deactivate
User Type :
Group : 1. 2. 3. 4.
Bypass TZ Level :
Personal Password : (4 ~ 8 digits.)
Personal Confirm :

SEMIAR

◆ Modify User List in “View User List”

▶ User Record	
User ID	Self-define User ID from number 1~20,000 is allowed only.
Card No.	Manual input card no. in decimal format (when any card decoder installed, card no. can be read automatically)
Name	Input User’s Name (max. 31 characters)
Expire Date Check	Enable or Disable user’s authority expire date check
Effective From ~To	When “Expire Date Check” enabled. It requires to enter a period of date time.
Status	“Activate” or “Deactivate” user access authority for system
User Type	<p>Card Types of the User. The “Drop Down Menu” will list out cards for Normal User , Super User, Visitor, Guard Touring, Defense Card , Manager Card-Add and Manager-Card-Delete as your choice. The Respective definitions are as below :</p> <p>Normal User: System default type for common users.</p> <p>Super User Card: Not constrained by APB (Anti Pass Back) rule.</p> <p>Visitor Card: Program visitor cards with certain date access permission (expired date check)</p> <p>Guard Touring Card: Door won’t open when Guard Touring card punched but log will be kept on system.</p> <p>Defense Card: When the card sweeps the door, all the doors will activate Access Control at once. Any type of cards cannot access the door until the Defense Card punch again to restore normal functions.</p>
Group	Each user can be assigned to 4 different groups. All of the group names existed will be automatically listed out by the “Drop Down Menu” for your choice. “Free Time Group” is a “Default Group”.
Bypass TZ Level	The “Bypass Time Zone Level” of each user is from L1~L10. When user’s Bypass TZ level >Door Bypass TZ Level, User may access door by card only. When user’s Bypass TZ level < Door’s Bypass TZ level, user should access the door by door’s setup bypass level.
Personal Password	4~8 digits allow only
Personal Confirm	Reconfirm Personal Password.
▶ Button	
Previous	Modify previous user record.
Save	Save the modified user record.
Delete	Delete existing user record.
Next	Modify next user record.

◆ Add User

Select "Add User" on the Main Window, you'll see the User Record " screen for Add New User as the following picture:

Add New User

REG : Single Continuous Amount :

User ID : (1 ~ 20000)

Card No. : (DEC)

Name : (Max 31 chars.)

Expire Date Check : Disable Enable

From 2014 (Y) 02 (M) 06 (D) 15 (H) 0 (M)

To 2014 (Y) 02 (M) 06 (D) 15 (H) 0 (M)

Status : Activate Deactivate

User Type : Normal User

Group : 1. Free Time Group 2. Disallowed Group 3. Disallowed Group 4. Disallowed Group

Bypass TZ Level : L1

Personal Password : (4 ~ 8 digits.)

Personal Confirm :

SEMVA

◆ Illustration of Add New User

► User Record	
REG	Single: Only one user can be registered each time. Continuous: It allows you to register 1~20000 users continually. You may input required q'ty in the textbox of Amount. However, only the serial number is accepted and supported.
User ID	Self-define User ID from number 1~20,000 is allowed only.
Card No.	Manual input card no. in decimal format (when any card decoder installed, card no. can be read automatically)
Name	Input User's Name (max. 31 characters)
Expire Date Check	Enable or Disable user's authority expire date check
Effective From ~To	When "Expire Date Check" enabled. It requires to enter a period of date time.
Status	"Activate" or "Deactivate" user access authority for system
User Type	<p>Card Types of the User. The "Drop Down Menu" will list out cards for Normal User , Super User, Visitor, Guard Touring, Defense Card , Manager Card-Add and Manager-Card-Delete as your choice. The Respective definitions are as below :</p> <p>Normal User: System default type for common users.</p> <p>Super User Card: Not constrained by APB (Anti Pass Back) rule.</p> <p>Visitor Card: Program visitor cards with certain date access permission (expired date check)</p> <p>Guard Touring Card: Door won't open when Guard Touring card punched but log will be kept on system.</p> <p>Defense Card: When the card sweeps the door, all the doors will activate Access Control at once. Any type of cards cannot access the door until the Defense Card punch again to restore normal functions.</p>
Group	Each user can be assigned to 4 different groups. All of the group names existed will be automatically listed out by the "Drop Down Menu" for your choice. "Free Time Group" is a "Default Group".
Bypass TZ Level	The "Bypass Time Zone Level" of each user is from L1~L10. When user's Bypass TZ level > Door Bypass TZ Level, User may access door by card only. When user's Bypass TZ level < Door's Bypass TZ level, user should access the door by door's setup bypass level.
Personal Password	4~8 digits allow only
Personal Confirm	Reconfirm Personal Password.
► Button	
Save	Save user records.

➤ Terminal

◆ Terminal Status

Select and Click”Terminal Status” on the left side of the Main Window, you’ll see the “Terminal Status” screen. This screen is the Main Window for Logon. It displays the current Terminal Status and relative information of WEB setup, referring to the following picture:



TERMINAL STATUS	
Product Name :	SEMAC-D4(20000)
Serial No. :	036fde(113822)
Firmware Version :	1.00.00,Dec 23 2013(HW1.1)
System Time :	02/06/2014 15:08:52
Terminal ID(MAC Address) :	1(00:0e:e3:03:8f:de)
IP Address :	192.168.2.68
Subnet mask :	255.255.255.0
Default Gateway :	192.168.2.1
Primary DNS :	168.95.1.1
Listen Port/Software IP(status) :	2000/192.168.2.182(Offline)
Web Management Port :	68
Registered User :	1
Available User Capacity :	19999
Access/System Log Count :	0/40
Reader Type :	WG34
Anti-Pass-Back(Tolerance Timer) :	Disabled(0)
Anti-Duress :	Disabled
Next SEMAC(status) :	0.0.0.0(Offline)

◆ Illustration of Terminal Status

► Terminal Status	
Product Name	Model Number of SEMAC-D4
Serial No.	Serial Number of SEMAC-D4
Firmware Version	Firmware and Hardware Version of SEMAC-D4
System Time	System Time of SEMAC-D4
Terminal ID (MAC Address)	Terminal ID and MAC address of SEMAC-D4
IP Address	Current IP address of SEMAC-D4
Subnet mask	Subnet mask of SEMAC-D4
Default Gateway	Default Gateway address of SEMAC-D4
Primary DNS	Primary DNS address of SEMAC-D4
Listen Port/Software IP(status)	Listen Port and Networking Software IP address (status : Online or Offline)
WEB Management Port	WEB communication number of SEMAC-D4
Registered User	Registered user number of SEMAC-D4
Available User Capacity	Available Capacity of SEMAC-D4 to register users; Available user number(s) to be registered = Sum (20000) – Registered user(s)
Access/System Log Count	The Sum from access and system logs of SEMAC-D4
Reader Type	Indicated connected reader format (default is WG34)
Anti-Pass-Back (Tolerance Time)	Current APB status (Enable or Disable) on SEMAC-D4, indicating with (APB Tolerance Time)
Anti-Duress	Current Anti-Duress status (Enable or Disable) on SEMAC-D4.
Next SEMAC(status)	IP Address of Next SEMAC-D4 which interaction with first APB (anti pass-back) function and Fire Alarm door emergency open. Also indicating with connectivity status (Online or Offline)

◆ Terminal Setup

Select and Click”Terminal Setup” on the left side of the Main Window, you’ll see the “Terminal Configuration”, referring to the following picture:

Terminal Configuration

Terminal Setting : Terminal ID :

*IP Address : . . .

*Subnet Mask : . . .

*Gateway : . . .

*DNS Server : . . .

Software : *TCP Port(Software Used) : *Software IP :

Web Language : ▾

Anti Pass Back : Enable Anti Follow Disable

Tolerance Timer (Minute, Maximum 65535, 0 means No Tolerance)

Anti Duressed : Enable Disable

Password * (Max 3 digits,default is 9)

WEB Management Port : Http Port:

Next SEMAC(for APB): IP Address : . . .

Fast Reg Card Mode : Enable Disable

Terminal may need to restart after configuration saved.

SEMI

◆ Illustration of Terminal Configuration

▶ Terminal Configuration	
Terminal Setting: Terminal ID	Setting Terminal ID for current SEMAC-D4. Default ID=1, max. 65,535 (Terminal ID should not be duplicated in one system)
IP Address	Setting IP Address of SEMAC-D4.
Subnet Mask	Setting Subnet Mask of SEMAC-D4
Gateway	Setting Default Gateway of SEMAC-D4
DNS Server IP Address	Setting the DNS Server IP Address of SEMAC-D4. Default DNS Server IP Address is 168.95.1.1.
▶ Software	
TCP Port (Software Used)	Setting a TCP Port for Software to communicate with SEMAC-D4. Default TCP Port No. is 2000
Software IP	For setting the Software IP to communicate with SEMAC-D4 Default Software IP is 0.0.0.0.
▶ Web Language	
English	When you choose the "English" language from the "Drop Down Menu", the WEB page of SEMAC-D4 will be switched to "English" interface .
Chs	When you choose the "Chs" language from the "Drop Down Menu", the WEB page of SEMAC-D4 will be switched to "Simplified Chinese" interface .
Others	When you choose "Others" from the "Drop Down Menu", the WEB page of SEMAC-D4 will be switched to "Traditional Chinese" interface or other languages.
▶ Anti Pass Back	
Enable	Tick this circle to enable the "APB"(Anti Pass Pack) function.
Anti Follow	Automatically set all door(s) with APB level: Entry (IN): 1, Exit (OUT):2. User should access door only from Entry side then exit from Exit side.
Disable	Tick this circle to disable the "APB"(Anti Pass Pack) function.
Tolerance Time	Set a time that system will be restored to original status after "APB" triggered. The unit of time can be 0~65535(minute). For value set to "0" which indicated APB function will not be restored to normal after certain time until manually disable "APB" function. (Default value=0)
▶ Anti Duress	
Enable	Tick this circle to enable the "Anti Duress" function.
Disable	Tick this circle to disable the "Anti Duress"function.

Password	Set a set of password for “Anti Duress” function. Default value = 9, max. 3 digits.
► WEB Management Port	
Http Port	Set your WEB communication port for SEMAC-D4, default value=80.
► Next SEMAC(for APB)	
IP Address	Set IP address for Next SEMAC-D4. All the APB level setting from first SEMAC-D4 will be copied to next SEMAC-D4.
► Button	
Save	Save the Terminal configuration settings.

SEMAC-D4

◆ Password Setup

Select "Password Setup" on the left side of the Main Window, you'll see the "WEB Logon Setting/Entrance Password" screen, referring to the following picture:

WEB Logon Setting

Administrator WEB Logon User Name : (47 Char. Max)

Administrator WEB Logon Password : (35 Char. Max)

Operator WEB Logon User Name : (47 Char. Max)

Operator WEB Logon Password : (35 Char. Max)

USER WEB Logon User Name : (47 Char. Max)

USER WEB Logon Password : (35 Char. Max)

SAVE

Entrance Password

Administrator Password : (4 ~ 8 digits.)

Common Password : (4 ~ 8 digits.)

SAVE

SEMI

◆ Illustration of WEB Logon Setting/Entrance Password

▶ WEB Logon Setting	
Administrator WEB Logon User Name	Input the required Administrator's logon user name for WEB management, max. 47 characters, default value: "admin".
Administrator WEB Logon Password	Input the required Administrator's logon password for WEB management, max. 35 digits, default value: "admin".
Operator WEB Logon User Name	Input the required Operator's logon user name for WEB management, max. 47 characters, default value: "user".
Operator WEB Logon Password	Input the required Operator's logon password for WEB management, max. 35 digits, default value: "user".
User WEB Logon User Name	Input the required User's logon user name for WEB management, max. 47 characters, default value: "user0".
User WEB Logon Password	Input the required User's logon user name for WEB management, max. 35 digits, default value: "user0".
The Administrator, Operator and User have their respective authorizations, referring to the following "Authorization Table".	
▶ Button	
Save	Save all the WEB Logon Settings.
▶ Entrance Password	
Common Password	Set your "Common Password" here. Meanwhile, you have to select "001 Any Time "for "Common Password Time Zone " simultaneously to support this setting (for example: Door Setup→Door Setting→Click "Door1"→Door 1 Setting→ Select "Common Password Time Zone "→Select "001 Any Time "from the "Drop Down Menu"). Default value: "1234".
▶ Button	
Save	Save the Password setting.

Authorizations Table (“●” = Access Permission)

WEB Function	Administrator User Name: admin Password : admin	Operator User Name: user Password : user	User User Name: user0 Password : user0
Upgrade Firmware	●		
Password Setup	●		
Terminal Setup	●		
Door Setup	●		
Event Handle	●		
Reboot	●		
Clock Setup	●		
Reset	●		
Upgrade Firmware	●		
Password Setup	●		
Terminal Setup	●		
User Data	●	●	
Time Set	●	●	
Time Zone Setup	●	●	
Group List	●	●	
Holiday Setup	●	●	
Multi Badge Group	●	●	
Remote Control	●	●	
Access Log	●	●	●
View User List	●	●	●
Terminal Status	●	●	●
System Log	●	●	●
IP Camera	●	●	●

◆ System Log

Select "System Log" on the left side of the Main Window, you'll see "System Log" screen as the following picture:

System Log

No.	Date	Time	Description
1 .	09/15/2009	13:46:44	Disconnected by Server
2 .	09/15/2009	13:43:39	PC Server Connected
3 .	09/15/2009	13:43:06	Connect PC Server Fail
4 .	09/15/2009	13:39:51	Set Date(09/09/15)Day(2)Time(13:39:52) via Software
5 .	09/15/2009	13:39:50	PC Server Connected
6 .	09/15/2009	13:30:37	Connect PC Server Fail
7 .	09/15/2009	13:29:51	System Warm Start
8 .	09/15/2009	13:29:50	System Terminal Setup from Web
9 .	09/15/2009	13:29:41	System Warm Start
10 .	09/15/2009	13:29:40	System Terminal Setup from Web
11 .	09/15/2009	13:16:08	Connect PC Server Fail
12 .	09/15/2009	13:15:27	Disconnected by Server
13 .	09/15/2009	13:14:01	PC Server Connected
14 .	09/15/2009	13:12:59	Connect PC Server Fail
15 .	09/15/2009	13:12:18	Disconnected by Server
16 .	09/15/2009	13:11:28	PC Server Connected
17 .	09/15/2009	13:08:52	Connect PC Server Fail
18 .	09/15/2009	13:08:11	Disconnected by Server
19 .	09/15/2009	13:07:39	PC Server Connected
20 .	09/15/2009	12:00:00	Connect PC Server Fail

Total 76 Record(s) << [First](#) | [Prev 10](#) | [1](#) [2](#) [3](#) [4](#) | [Next 10](#) | [End](#) >>

◆ Illustration of System Log

► System Log	
No.	Serial Number of the log
Date	Date of the log
Time	Time of the log
Description	Description of the system operation records
※ Max. logs capacity : 1536 entries, for checking by authorized person(s) only, no logs export provide.	

◆ Clock Setup

Select and Click "Clock Setup" on the left side of the Main Window, you'll see the "System Clock Setup" screen, referring to the following picture:

SYSTEM CLOCK SETUP

Time Server : Disable Enable

Recommend: time.windows.com or time.nist.gov

Time Zone:

New Date : (mm/dd/yyyy)

New Time : (hh:mm:ss)

◆ Illustration of System Clock Setup

► Time Server	
Disable	Tick this circle to shut up the Time Server network connection.
Enable	Tick this circle to start the Time Server network connection.
Time Zone	The "Drop Down Menu" offers you all the Time Zones available up to your option, default time zone : (GMT)England.
"Save" button	Save the Time Server Settings and adjust the time.
When enable the "Time Server", please key in the IP address or http:// of the "Time Server". Then select the required Time Zone and Save it to connect the "Time Server" for a time adjustment.	
New Date	The date of networked PC computer. You may adjust the date to your requirement as the format of " mm/dd/yyyy ".
New Time	The date of networked PC computer. You may adjust the time to your requirement as the format of " hh:mm:ss ".
"Save" button	Save the configuration of this page and upgrade the date/time for the networked PC computer.

➤ Access Control

◆ Time Set

Select and Click “Time Set” on the left side of the Main Window, you’ll see the “Time Set” screen, referring to the following picture:

Time Set

Time Set List :

000	00:00 ~ 00:00		001	00:00 ~ 23:59	
002	04:00~17:00	DELETE	003	18:00~23:00	DELETE
004	02:00~05:30	DELETE	005	15:00~19:00	DELETE
006	16:00~19:00	DELETE	007	07:00~16:00	DELETE
008	17:30~21:30	DELETE	009	03:45~09:30	DELETE
010	10:00~14:00	DELETE	011	09:00~17:00	DELETE
012	17:00~22:00	DELETE	013	00:00~13:00	DELETE
014	19:00~23:00	DELETE	015	07:30~15:00	DELETE
016	16:00~20:00	DELETE	017	12:58~19:56	DELETE
018	12:58~18:59	DELETE	019	02:00~08:00	DELETE
020	03:00~05:00	DELETE	021	07:00~13:00	DELETE

Time Set : From H : M To H : M

◆ Illustration of Time Set

▶ Time Set List	
Time Set List	It will display all the configured time set(s). The System Default Time sets are: 00:00~00:00 and 00:00~23:59.
Time Set	Select your time set serial number. The “Drop Down Menu” offers you all the options for your choice, max. 255 time sets allowed. System built-in values are “000” and “001”.
From ~ To	Input a time set period, for example : 8:00am to 17:00pm as one period, then Time Set : <input type="text" value="002"/> From <input type="text" value="00"/> H : <input type="text" value="00"/> M To <input type="text" value="23"/> H : <input type="text" value="59"/> M <input type="button" value="SET"/> It is the same way to the others.
▶ Button	
Delete	Delete an existing “Time Set”.
Set	Add a new “Time Set”.

◆ Time Zone Setup

Select and Click "Time Zone Setup" on the left side of the Main Window, you'll see the "Time Zone List" screen as below:

Time Zone List

Time Zone List :

000	Deactivate		001	Any Time	
002	2	DELETE	003	3	DELETE
004	4	DELETE	005	5	DELETE

Time Zone ID :

◆ Illustration of Time Zone List

▶ Time Zone List	
Time Zone List	Display all the Time Zone(s) existing. Click the Time Zone name(indicated as the Time Zone Name example) to enter its Time Zone Information Screen.
Time Zone ID	Select your Time Zone Serial Number from the "Drop Down Menu", system built-in numbers as "000" and "001", max. 120 Time Zones allowed.
Time Zone Name	Click the name of Time Zone (for example : 2, as below picture) to enter the "Time Zone Information" screen for modification.
▶ Button	
Delete	Delete an existing Time Zone.
Set	Enter the Time Zone Information screen.

※ Example of "Time Zone Information" screen to show how to set the daily door access and card punching authorized Time Set from Monday to Sunday and Holidays:

Time Zone Information -- 002

Day : Monday ▾

Time 1: 000 -- 00:00 ~ 00:00 ▾	Time 2: 000 -- 00:00 ~ 00:00 ▾	Time 3: 000 -- 00:00 ~ 00:00 ▾	Time 4: 000 -- 00:00 ~ 0
Time 5: 000 -- 00:00 ~ 00:00 ▾	Time 6: 000 -- 00:00 ~ 00:00 ▾	Time 7: 000 -- 00:00 ~ 00:00 ▾	Time 8: 000 -- 00:00 ~ 0
Time 9: 000 -- 00:00 ~ 00:00 ▾	Time 10: 000 -- 00:00 ~ 00:00 ▾	Time 11: 000 -- 00:00 ~ 00:00 ▾	Time 12: 000 -- 00:00 ~ 0
Time 13: 000 -- 00:00 ~ 00:00 ▾	Time 14: 000 -- 00:00 ~ 00:00 ▾	Time 15: 000 -- 00:00 ~ 00:00 ▾	Time 16: 000 -- 00:00 ~ 0

Save Cancel

	Monday	Tuesday	Wednesday	Thursday	Friday	Saturday	Sunday	Hc
Time 1:	000 -- 00:00 ~ 00:00	000 -- 00:00 ~ 00:00	000 -- 00:00 ~ 00:00	000 -- 00:00 ~ 00:00	000 -- 00:00 ~ 00:00	000 -- 00:00 ~ 00:00	000 -- 00:00 ~ 00:00	00
Time 2:	000 -- 00:00 ~ 00:00	000 -- 00:00 ~ 00:00	000 -- 00:00 ~ 00:00	000 -- 00:00 ~ 00:00	000 -- 00:00 ~ 00:00	000 -- 00:00 ~ 00:00	000 -- 00:00 ~ 00:00	00
Time 3:	000 -- 00:00 ~ 00:00	000 -- 00:00 ~ 00:00	000 -- 00:00 ~ 00:00	000 -- 00:00 ~ 00:00	000 -- 00:00 ~ 00:00	000 -- 00:00 ~ 00:00	000 -- 00:00 ~ 00:00	00
Time 4:	000 -- 00:00 ~ 00:00	000 -- 00:00 ~ 00:00	000 -- 00:00 ~ 00:00	000 -- 00:00 ~ 00:00	000 -- 00:00 ~ 00:00	000 -- 00:00 ~ 00:00	000 -- 00:00 ~ 00:00	00
Time 5:	000 -- 00:00 ~ 00:00	000 -- 00:00 ~ 00:00	000 -- 00:00 ~ 00:00	000 -- 00:00 ~ 00:00	000 -- 00:00 ~ 00:00	000 -- 00:00 ~ 00:00	000 -- 00:00 ~ 00:00	00
Time 6:	000 -- 00:00 ~ 00:00	000 -- 00:00 ~ 00:00	000 -- 00:00 ~ 00:00	000 -- 00:00 ~ 00:00	000 -- 00:00 ~ 00:00	000 -- 00:00 ~ 00:00	000 -- 00:00 ~ 00:00	00

◆ Illustration of Time Zone Information

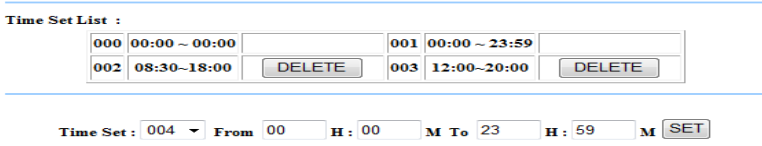
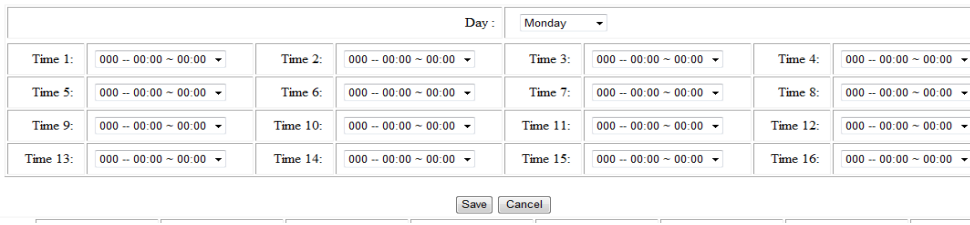
► Time Zone Information Settings	
Weekday (Day)	The “Drop Down Menu ”offers options from Monday to Sunday and Holiday. Steps:“SET”the Time Set on “Time Set” screen→Select a weekday→Choose your time set(s) of the time zones.
Time 1 ~ Time16	<p>Each day from Monday ~Sunday and Holiday is allowed to set 16 time sets. However, you have to make some Time Sets on the “Time Set” screen in advance for the options here, otherwise only 2 default Time sets for option, referring to the following illustration:</p> <p><u>Step 1 : “Time Set” screen to “SET” some time sets</u></p> <p>Time Set</p>  <p><u>Step 2 : “Time Zone Information” screen for more options than original 2 default time sets</u></p> <p>Time Zone Information -- 002</p> 
► Button	
Save	Save the“Time Zone Information”.
Cancel	Cancel or Modify the “Time Zone Information”.
When the “ Time Zone Setup “ completed, please click the “Time Zone Name ”to enter its “Time Zone Information” screen and see the list with all of its time sets as below picture	

◆ Group List

Select "Group List" on the left side of the Main Window, you'll see the "Group List" screen as below:

Group List

Group List :

000	Disallowed Group		001	Free Time Group	
002	2	DELETE	003	3	DELETE
004	4	DELETE			

Group ID : 005

◆ Illustration of Group List

▶ Group List																			
Group List	<p>Display all the Groups configured. Click the Group's name to enter its "Group Information" as below : (for example: click Group Name "4" as picture 14)</p> <p>Group Information</p> <hr/> <table> <tr> <td>Allowed Door :</td> <td>Time Zone ID :</td> </tr> <tr> <td><input checked="" type="checkbox"/> 1.</td> <td>002 2</td> </tr> <tr> <td><input checked="" type="checkbox"/> 2.</td> <td>004 4</td> </tr> <tr> <td><input checked="" type="checkbox"/> 3.</td> <td>001 Any Time</td> </tr> <tr> <td><input checked="" type="checkbox"/> 4.</td> <td>003 3</td> </tr> <tr> <td><input type="checkbox"/> 5.</td> <td>000 Deactivate</td> </tr> <tr> <td><input type="checkbox"/> 6.</td> <td>000 Deactivate</td> </tr> <tr> <td><input checked="" type="checkbox"/> 7.</td> <td>001 Any Time</td> </tr> <tr> <td><input type="checkbox"/> 8.</td> <td>000 Deactivate</td> </tr> </table> <p style="text-align: right;"><input type="button" value="SAVE"/> <input type="button" value="CANCEL"/></p>	Allowed Door :	Time Zone ID :	<input checked="" type="checkbox"/> 1.	002 2	<input checked="" type="checkbox"/> 2.	004 4	<input checked="" type="checkbox"/> 3.	001 Any Time	<input checked="" type="checkbox"/> 4.	003 3	<input type="checkbox"/> 5.	000 Deactivate	<input type="checkbox"/> 6.	000 Deactivate	<input checked="" type="checkbox"/> 7.	001 Any Time	<input type="checkbox"/> 8.	000 Deactivate
Allowed Door :	Time Zone ID :																		
<input checked="" type="checkbox"/> 1.	002 2																		
<input checked="" type="checkbox"/> 2.	004 4																		
<input checked="" type="checkbox"/> 3.	001 Any Time																		
<input checked="" type="checkbox"/> 4.	003 3																		
<input type="checkbox"/> 5.	000 Deactivate																		
<input type="checkbox"/> 6.	000 Deactivate																		
<input checked="" type="checkbox"/> 7.	001 Any Time																		
<input type="checkbox"/> 8.	000 Deactivate																		
Group ID	<p>Select your "Group ID" by serial number, default values : 000 · 001. The "Drop Down Menu" offers you all the serial number of Group ID as options, max. 255 groups allowed.</p>																		
▶ Button																			
Delete	Delete a Group ID.																		
Set	Enter the "Group Information" screen.																		

This is a screen to configure the door(s) of a Group ID, referring to the following picture:

Group Information

Allowed Door :	Time Zone ID :
<input type="checkbox"/> 1.	000 Deactivate ▼
<input type="checkbox"/> 2.	000 Deactivate ▼
<input type="checkbox"/> 3.	000 Deactivate ▼
<input type="checkbox"/> 4.	000 Deactivate ▼
<input type="checkbox"/> 5.	000 Deactivate ▼
<input type="checkbox"/> 6.	000 Deactivate ▼
<input type="checkbox"/> 7.	000 Deactivate ▼
<input type="checkbox"/> 8.	000 Deactivate ▼
<input type="button" value="SAVE"/> <input type="button" value="CANCEL"/>	

◆ Illustration of Group Information

▶ Allowed Door	
Door 1	Tick the box of Door 1, then the user(s) assigned to the Group can be access Door 1 within the “Time Zone ID” indicated, otherwise prohibited.
Door 2	Tick the box of Door 2, then the user(s) of this Group can access Door 2 within the “Time Zone ID” indicated, otherwise prohibited.
Door 3	Tick the box of Door 3, then the user(s) of this Group can access Door 3 within the “Time Zone ID” indicated, otherwise prohibited.
Door 4	Tick the box of Door 4, then the user(s) of this Group can access Door 4 within the “Time Zone ID” indicated, otherwise prohibited.
Tim Zone ID	The “Drop Down Menu” displays all the “Time Zones” configured in the “Time Zone Setup” for option.
▶ Button	
Save	Save the “Group Information”.
Cancel	Cancel or Modify the “Group Information”

◆ Holiday Setup

Select "Holiday Setup" on the left side of the Main Window, you'll see the "Holiday setup" screen as below:

Holiday setup

01 ▾ Month / 01 ▾ Date

Holiday List :

01 / 01	<input type="button" value="DELETE"/>	01 / 02	<input type="button" value="DELETE"/>	01 / 03	<input type="button" value="DELETE"/>
---------	---------------------------------------	---------	---------------------------------------	---------	---------------------------------------

◆ Illustration of Holiday Setup

▶ Holiday Setup	
Month	Select a month from the "Drop Down Menu".
Date	Select a date from the "Drop Down Menu".
▶ Button	
Set	Add a new Holiday.
Delete	Delete a Holiday.

◆ Door Setup

Select and Click”Door Setup” on the Main Window, you’ll see the “Door setting” screen as below:

Door Setting

		<u>Door 1</u>	<u>Door 2</u>	<u>Door 3</u>	<u>Door 4</u>
L10	First Admin Card IN TZ	000	000	000	000
L9	2/3 Badge+Admin P TZ	0(2)/0(2)	0(2)/0(2)	0(2)/0(2)	0(2)/0(2)
L8	2/3 Badge+Personal P TZ	0(2)/0(2)	0(2)/0(2)	0(2)/0(2)	0(2)/0(2)
L7	2/3 Badge TZ	0(2)/0(2)	0(2)/0(2)	0(2)/0(2)	0(2)/0(2)
L6	Card+Admin P TZ	0/0	0/0	0/0	0/0
L5	Admin P TZ	0/0	0/0	0/0	0/0
L4	Card+Personal P TZ	0/0	0/0	0/0	0/0
L3	P TZ	0/0	0/0	0/0	0/0
L2	Card Only TZ	0/0	0/0	0/0	0/0
L1	Card or P TZ	1/1	1/1	1/1	1/1
	Lock Release TZ	000	000	000	000
	Exit Button TZ	001	001	001	001
	APB IN/OUT	0/0	0/0	0/0	0/0
	Multiple Interlocking	N	N	N	N
	Remote Grant Needed	N	N	N	N
	Open Delay Time	10	10	10	10
	Door Open Delay Time	10	10	10	10
	Still Open Delay Time	0	0	0	0
	Degrade Mode	Deactivate	Deactivate	Deactivate	Deactivate
	Log Recorded/Sensor Mode	Y/None	Y/None	Y/None	Y/None

◆ Illustration of Door Setting

► Door Setting	
L10 : First Admin Card IN TZ	Display the First Admin Card IN Time Zone from Door 1 to Door 4.
L9: 2/3 Badge +Admin P TZ	Display the Multiple Badge+ Admin Password Time Zone from Door 1 to Door 4, accompanied by a Double or Triple verifications.
L8: 2/3 Badge +Personal P TZ	Display the Multiple Badge +Personal Password Time Zone from Door 1 to Door 4, accompanied by a Double or Triple verifications.
L7: 2/3 Badge TZ	Display the Multiple Badge Time Zone from Door 1 to Door 4, accompanied by a Double or Triple verifications.
L6: Card + Admin P TZ	Display the Card +Admin Password Time Zone from Door 1 to Door 4.
L5: Admin P TZ	Display the Admin Password Time Zone from Door 1 to Door 4.
L4: Card + Personal TZ	Display the Card +Personal Password Time Zone from Door 1 to Door 4.
L3: Common Password TZ	Display the Common Password Time Zone from Door 1 to Door 4.
L2: Card Only TZ	Display the Card Only Time Zone from Door 1 to Door 4.
L1: Card or Common Password TZ	Display the Card or Common Password Time Zone from Door 1 to Door 4.
Lock Release TZ	Display the Lock Release Time Zone from Door 1 to Door 4.
Exit Button TZ	Display the Exit Button TZ from Door 1 to Door 4.
APB IN/OUT	Display the Anti Pass Back Level from Door 1 to Door 4, APB level : 0-255 for door IN/OUT.
Multiple-Door Interlocking	Display the Dual Interlocking function from Door 1 to Door 4, “Enabled” or “Disabled”.
Remote Grant Needed	Display the Remote Grant function from Door 1 to Door 4, “Enabled” or “Disabled”.
Lock Release Time (Open Delay Time)	Display the Door Lock Release Time from Door 1 to Door 4, 1 – 65535 seconds allowed and 10 seconds = default.
Door Open Delay Time	Display the Door Open Delay Time from Door 1 to Door 4, 10 seconds = default.
Still Open Delay Time	Set a time period (0~255 seconds) to adjust door sensor/relay reaction

Door 1 Setting

First Admin Card IN Time Zone :	000 Deactivate ▾
Multiple Badge+Admin Password Time Zone :	000 Deactivate ▾ Double ▾
Multiple Badge+Personal Password Time Zone :	000 Deactivate ▾ Double ▾
Multiple Badge Time Zone :	000 Deactivate ▾ Double ▾
Card+Admin Password Time Zone :	000 Deactivate ▾
Admin Password Time Zone :	000 Deactivate ▾
Card+Personal Password Time Zone :	000 Deactivate ▾
Password Time Zone :	000 Deactivate ▾
Card Only Time Zone :	000 Deactivate ▾
Card or Password Time Zone :	001 Any Time ▾
Lock Release Time Zone :	000 Deactivate ▾ First Card No Need ▾
Exit Button TZ :	001 Any Time ▾
Anti Pass Back Level :	IN : 0 OUT : 0 (0 - 255)
Remote Grant Only:	Disabled ▾
Lock Release Time :	10 Sec (1 - 65535, 10 = default)
Door Open Delay Time :	10 Sec (1 - 65535, 10 = default)
Access Log :	Recorded ▾
Door Sensor Mode:	N/A ▾
Still Open Delay Time :	0 (1-255,0=default)
Degrade Mode :	Deactivate ▾

Set

2 3 4

SEMI

◆ Illustrations of Door 1 Setting in Door Setup

▶ Door 1 Setting	
<p>First Admin Card IN Time Zone</p>	<p>Set up the time zone of First Administrator's Card to open the door as the bypass time zone of Door 1 (default– "000 Deactivate"). When this time zone is chosen, the user can only use the card of Administrator to scan/sweep the controller first and the other users may enter Door 1. Nobody may enter without using this First Admin Card to scan the controller of Door 1 in advance.</p> <p>※ Should the user's bypass time zone level is L10, he/she may access by scanning the card and enter the Door 1 directly; however when the bypass time zone setup of Door 1 is " Lock Release Time Zone ", the user may access directly without any limitation.</p>
<p>Multiple Badge +Admin Password Time Zone</p>	<p>Set up the Multiple Badge + Administrator Password time zone as the bypass time zone of Door 1 (default– "000 Deactivate"). Before setting this time zone, you must choose the function of " Multi Badge Group "to come to the "Multi Badge Group " screen and give the user ID in this time zone, max. 3 user IDs allowed; the user needs both 2 or 3 user ID cards and the Administrator's password to enter the Door 1 successfully. No any order limitation for scanning the cards first or enter the password first. You may scan the cards first then enter the password, or in reverse order.</p> <p>※ Should the user's bypass time zone level is L9~L10, he/she may access by scanning the card and enter the Door 1 directly; however when the bypass time zone setup of Door 1 is " Lock Release Time Zone ", the user may access directly without any limitation.</p>
<p>Multiple Badge +Personal Password Time Zone</p>	<p>Set up the Multiple Badge + Personal Password time zone as the bypass time zone of Door 1 (default–000 Deactivate"). Before setting this time zone, you must choose the function of "Multi Badge Group"to come to the "Multi Badge Group" screen and give the user ID in this time zone, max. 3 user IDs allowed; the user needs both 2 or 3 user ID cards and the Personal password to enter the Door 1 successfully. No any order limitation for scanning the cards first or enter the password first. You may scan the cards first then enter the password, or in reverse order. However, the order of personal passwords will make differences. For example, there are two cards + passwords belonged to A and B. Should A card be scanned first, A has to enter his/her password first. Password B is not allowed to be entered before Password A.</p> <p>※ Should the user's bypass time zone level is L8~L10, he/she may access by scanning the card and enter the Door 1 directly; however when the bypass time zone setup of Door 1 is " Lock Release Time Zone ", the user may access directly without any limitation.</p>

<p>Multiple Badge Time Zone</p>	<p>Set up the Multiple Badge time zone as the bypass time zone of Door 1 (default-“ 000 Deactivate“). Before setting this time zone, you must choose the function of “Multi Badge Group”to come to the “Multi Badge Group” screen and give the user ID in this time zone, max. 3 user IDs allowed; the user needs both 2 or 3 user ID cards to enter the Door 1 successfully. No any order limitation for scanning the cards</p> <p>※ Should the user’s bypass time zone level is L7~L10, he/she may access by scanning the card and enter the Door 1 directly; however when the bypass time zone setup of Door 1 is“ Lock Release Time Zone “, the user may access directly without any limitation.</p>
<p>Card +Admin Password Time Zone</p>	<p>Set up the Card + Admin Password time zone as the bypass time zone of Door 1 (default-“ 000 Deactivate“). The user has to scan the card and enter the Admin Password to access Door 1. No any order limitation for scanning the cards first or enter the password first.</p> <p>※ Should the user’s bypass time zone level is L6~L10, he/she may access by scanning the card and enter the Door 1 directly; however when the bypass time zone setup of Door 1 is“ Lock Release Time Zone “, the user may access directly without any limitation.</p>
<p>Admin Password Time Zone</p>	<p>Set up the Admin Password time zone as the bypass time zone of Door 1 (default-“000 Deactivate“). The user has to enter the Admin Password to access Door 1.</p> <p>※ Should the user’s bypass time zone level is L5~L10, he/she may access by scanning the card and enter Door 1 directly; however when the bypass time zone setup of Door 1 is“ Lock Release Time Zone “, the user may access directly without any limitation.</p>
<p>Card +Personal Password Time Zone</p>	<p>Set up the Card+ Personal Password time zone as the bypass time zone of Door 1 (default-“ 000 Deactivate“). The user has to scan the card and enter the Personal Password to access Door 1. No any order limitation for scanning the cards first or enter the password first.</p> <p>※ Should the user’s bypass time zone level is L4~L10, he/she may access by scanning the card and enter Door 1 directly; however when the bypass time zone setup of Door 1 is“ Lock Release Time Zone “, the user may access directly without any limitation.</p>
<p>Password Time Zone</p>	<p>Set up the Common Password time zone as the bypass time zone of Door 1 (default-“000 Deactivate“). The user has to enter the Common Password to access Door 1.</p> <p>※ Should the user’s bypass time zone level is L3~L10, he/she may access by scanning the card and enter Door 1 directly; however when the bypass time zone setup of Door 1 is“ Lock Release Time Zone “, the user may access directly without any limitation.</p>

Card Only Time Zone	<p>Set up the Card Only time zone as the bypass time zone of Door 1 (default –“ 000 Deactivate“). The user has to scan the card to access Door 1.</p> <p>※ Should the user’s bypass time zone level is L2~L10, he/she may access by scanning the card and enter Door 1 directly; however when the bypass time zone setup of Door 1 is“ Lock Release Time Zone “, the user may access directly without any limitation.</p>
Card or Password Time Zone	<p>Set up the Card or Common Password time zone as the bypass time zone of Door 1 (default as “ 001 Any Time“). The user has to scan the card or enter the Common Password to access Door 1.</p> <p>※ Should the user’s bypass time zone level is L1~L10, he/she may access by scanning the card and enter Door 1 directly; however when the bypass time zone setup of Door 1 is“ Lock Release Time Zone “, the user may access directly without any limitation.</p>
Lock Release Time Zone	<p>Set up the Lock Release time zone as the bypass time zone of Door 1 (default–“000 Deactivate“). The user needs no any verification to access Door 1; however, if the“First Card”setup is “Needed”, the use has to scan a “First Card”in advance to activate the “Lock Release Time Zone” function.</p>
Exit Button TZ	<p>Set up the Exit Button time zone as the bypass time zone of Door 1, supporting “OUT ”for Door 1 only (default as “ 001 Any Time“).</p>
Anti Pass Back Level	<p>Set up the Anti Pass Back Level of “IN” and “OUT” for Door 1, level 0~255.</p>
Dual Interlocking	<p>Disable or Enable the “Dual Interlocking” function. Upon this function enabled, the user enters Door 1 and cannot enter the other door until Door 1 close.</p>
Remote Grant	<p>Disable or Enable the “Remote Grant” access control function. Upon this function enabled, the Software will take a remote control over the door’s open or close.</p>
Lock Release Time	<p>Set up the “Lock Release Time”, default as 10 seconds.</p>
Door Open Delay Time	<p>Set up “Door Open Delay Time” , default as 10 seconds.</p>
Access Log / Door Sensor Mode	<p>Set up “Ignored” or “Recorded”the Access Log (default as “Recorded”)</p> <p>Set up Door Sensor Mode, options for “Normal Open/Close” or “Circuit Short/Open” (default as “Normal Open/Close”). Should it is “Circuit Short/Open ” selected, the Door 1 Setting will display “Circuit Short” when the door is in short circuit or broken.</p>
Still Open Delay Time	<p>Set a time from 0~255 seconds for adjusting door sensor/relay reaction time difference</p>
Degrade Mode	<p>Select system verification mode: Deactivated/Registered/FC/ALL</p>

Remarks: Same setting for door 1 ~door 4

◆ Remote Control

Select and Click "Remote Control" on the left side of the Main Window, you'll see the "Door Status Monitoring /Security Bypass" screen as below:

Door Status Monitoring

● No Response ● close ● open ● Circuit Short, Circuit Open, Intrude, Open too long

	Door 1	Door 2	Door 3	Door 4
Door State	●	●	●	●
Fire Alarm Detection	off	Defense State		off

Security Bypass

	Door 1	Door 2	Door 3	Door 4
State	Normal	Normal	Normal	Normal

Door 1 Door 2 Door 3 Door 4

SEMA

◆ Illustrations of Door Status Monitoring/Security Bypass

► Door Status Monitoring	
Door Status	Display the most updated status from Door 1 to Door 4. No light Displayed indicated no response Green light indicated door closed Yellow light indicated door opened Red light indicated abnormal status (for example, short circuit, intruded, door opened too long, and so on)
Fire Alarm Detection	Display whether the “ Fire Alarm Detection ”function enabled or not.
Defense State	Display whether the “ Defense State ”function enabled or not.
► Security Bypass	
State	Display the “Security Bypass State” from Door 1 to Door 4, Normal/Force Open/Force Close.
Door 1	Tick the box of Door 1 to monitor the Security Bypass of Door 1.
Door 2	Tick the box of Door 2 to monitor the Security Bypass of Door 2.
Door 3	Tick the box of Door 3 to monitor the Security Bypass of Door 3.
Door 4	Tick the box of Door 4 to monitor the Security Bypass of Door 4.
Select All	Click this button and tick all the boxes from Door 1 to Door 4.
Cancel All	Click this button and cancel all the ticks of the boxes before Door 1 ~ Door 4.
Pulse Open Door	Click this button to open the door(s) remotely for all the door(s) ticked. This function works when the Security Bypass state is normal.
Force Close	Click this button to make a force close on the door(s) remotely for all the door(s) ticked. Hence the state(s) of all the door(s) ticked will display “Force Close “. Even the RFID card scanned through the door(s), you may not access the door(s).
Back to Normal	Click this button to remotely restore all the door(s) ticked back to normal Security Bypass status.
Force Open	Click this button to make a force open on the door(s) remotely for all the door(s) ticked. Hence the state(s) of all the door(s) ticked will display “Force Open “ and the door(s) will stay at “Lock Release ” status.
Emergency Open All Door	Click this button to make a force open on all the door(s) remotely and the door(s) will stay at “Lock Release” status.
Emergency Close All Door	Click this button to make a force close on all the door(s) remotely and the door(s) cannot be accessed normally.
Fire Alarm Detection ON	Click this button to activate the “Fire Alarm Detection” function and the door(s) state will display “on”.
Fire Alarm Detection OFF	Click this button to deactivate the “Fire Alarm Detection” function and the door(s) state will display “off”.
Alarm OFF	Click this button to deactivate all the Alarms already triggered.

◆ Event Handle

Select "Event Handle" on the left side of the Main Window, you'll see the "Event Handle" screen as below:

Event Handle

	Hard Alarm	Soft Alarm1	Soft Alarm2	IP Camera
Latched Time(Second)	0	0	0	0
Event				
Unregistered User	<input type="checkbox"/>	<input type="checkbox"/>	<input type="checkbox"/>	<input type="checkbox"/>
Deactivated User	<input type="checkbox"/>	<input type="checkbox"/>	<input type="checkbox"/>	<input type="checkbox"/>
Not Allowed Door	<input type="checkbox"/>	<input type="checkbox"/>	<input type="checkbox"/>	<input type="checkbox"/>
Time Zone Violation	<input type="checkbox"/>	<input type="checkbox"/>	<input type="checkbox"/>	<input type="checkbox"/>
Expired User	<input type="checkbox"/>	<input type="checkbox"/>	<input type="checkbox"/>	<input type="checkbox"/>
Anti Pass Back Violation	<input type="checkbox"/>	<input type="checkbox"/>	<input type="checkbox"/>	<input type="checkbox"/>
Door open too long	<input type="checkbox"/>	<input type="checkbox"/>	<input type="checkbox"/>	<input type="checkbox"/>
Door Intruded	<input type="checkbox"/>	<input type="checkbox"/>	<input type="checkbox"/>	<input type="checkbox"/>
Duress Alarm On	<input type="checkbox"/>	<input type="checkbox"/>	<input type="checkbox"/>	<input type="checkbox"/>
Fire Alarm On	<input type="checkbox"/>	<input type="checkbox"/>	<input type="checkbox"/>	<input type="checkbox"/>

SEMAAC

◆ Illustration of Event Handle

▶ Event Type	
Latched Time	<p>Set a latched time (0~65535 seconds) for Hard Alarm/Soft Alarm 1/Soft Alarm 2/IP Camera event trigger.</p> <p>Hard Alarm: Set Event to Trigger Hard Alarm</p> <p>Hard Alarm</p> <hr/> <p>Latched Time <input type="text" value="0"/> (sec,Max 65535 : 0 means unlimited)</p> <p> <input type="checkbox"/> Unregistered User <input type="checkbox"/> Deactivated User <input type="checkbox"/> Not Allowed Door <input type="checkbox"/> Time Zone Violation <input type="checkbox"/> Expired User <input type="checkbox"/> Anti Pass Back Violation <input type="checkbox"/> Door open too long <input type="checkbox"/> Door Intruded <input type="checkbox"/> Duress Alarm On <input type="checkbox"/> Fire Alarm </p> <p><input type="button" value="Set"/></p> <p>Soft Alarm 1 / Soft Alarm 2 :</p> <p>Soft Alarm1</p> <hr/> <p>Latched Time <input type="text" value="0"/> (sec,Max 65535 : 0 means unlimited)</p> <p> <input type="checkbox"/> Unregistered User <input type="checkbox"/> Deactivated User <input type="checkbox"/> Not Allowed Door <input type="checkbox"/> Time Zone Violation <input type="checkbox"/> Expired User <input type="checkbox"/> Anti Pass Back Violation <input type="checkbox"/> Door open too long <input type="checkbox"/> Door Intruded <input type="checkbox"/> Duress Alarm On <input type="checkbox"/> Fire Alarm </p> <p><input type="button" value="Set"/></p> <p>Soft Alarm2</p> <hr/> <p>Latched Time <input type="text" value="0"/> (sec,Max 65535 : 0 means unlimited)</p> <p> <input type="checkbox"/> Unregistered User <input type="checkbox"/> Deactivated User <input type="checkbox"/> Not Allowed Door <input type="checkbox"/> Time Zone Violation <input type="checkbox"/> Expired User <input type="checkbox"/> Anti Pass Back Violation <input type="checkbox"/> Door open too long <input type="checkbox"/> Door Intruded <input type="checkbox"/> Duress Alarm On <input type="checkbox"/> Fire Alarm </p> <p><input type="button" value="Set"/></p> <p>IP Camera: Even trigger type from IP Camera</p> <p>IP Camera</p> <hr/> <p> <input type="checkbox"/> Unregistered User <input type="checkbox"/> Deactivated User <input type="checkbox"/> Not Allowed Door <input type="checkbox"/> Time Zone Violation <input type="checkbox"/> Expired User <input type="checkbox"/> Anti Pass Back Violation <input type="checkbox"/> Door open too long <input type="checkbox"/> Door Intruded <input type="checkbox"/> Duress Alarm On <input type="checkbox"/> Fire Alarm </p> <p><input type="button" value="Set"/></p>
Unregistered User	<p>1、It will be listed in the “Drop Down Menu”. When it’s selected and the user unregistered, one unregistered record will be shown on the “Access Log” screen (referring to the sample as below); if the event level equal to or higher than the “Alarm Trigger Level”, the Relay will be triggered and the E-mail will alert when “E-mail Alerts” is configured and one alert e-mail will be sent out.</p> <p>2、When the “Latched Time : 0”, the alert can only be lifted/stopped by clicking “Alarm OFF” button on the “Door Status Monitoring/Security Bypass” screen of “Remote Control” function, default level = 0, referring to the below picture :</p>

<p>Deactivated User</p>	<p>1、It will be listed in the “Drop Down Menu”. When it’s selected and the user deactivated, one “Deactivated” message will be recorded and shown on the “Access Log”screen (referring to the example as below); if the event level equal to or higher than the “Alarm Trigger Level”, the Relay will be triggered and the E-mail will alert when “E-mail Alerts”is configured and one alert e-mail will be sent out.</p> <p>2、When the “Latched Time : 0”, the alert can only be lifted/stopped by clicking “ Alarm OFF ”button on the “Door Status Monitoring/Security Bypass” screen of “Remote Control” function, default level = 0.</p>
<p>Not Allowed Door</p>	<p>1、It will be listed in the “Drop Down Menu”. When it’s selected and the user’s “Group” setting different from the Door Settings, one “DISALLOWED DOOR” message will be recorded and shown on the “ Access Log ”screen; if the event level equal to or higher than the “Alarm Trigger Level”, the Relay will be triggered and the E-mail will alert when “ E-mail Alerts ”is configured and one alert e-mail will be sent out. (referring to below examples of user’s Group setting and Door setting) (steps : Access Log(Click the User ID(Enter the “User RECORD” screen to modify the configuration of “Group”)</p> <p>2、When the “Latched Time : 0”, the alert can only be lifted/stopped by clicking “ Alarm OFF ”button on the “Door Status Monitoring/Security Bypass” screen of “Remote Control” function, default level = 0.</p>
<p>Multi-Badge Violation</p>	<p>1、It will be listed in the “Drop Down Menu”. When it’s selected and the “Multi-Badge “ verification failed, one “(1)DOUBLE REJ” message will be recorded and shown on the “ Access Log” screen (referring to the example as below); if the event level equal to or higher than the” Alarm Trigger Level”, the Relay will be triggered and the E-mail will alert when “ E-mail Alerts ”is configured and one alert e-mail will be sent out.</p> <p>2、When the “Latched Time : 0”, the alert can only be lifted/stopped by clicking “ Alarm OFF ”button on the “Door Status Monitoring/Security Bypass” screen of “Remote Control” function, default level = 0.</p>
<p>Time Zone Violation</p>	<p>1、It will be listed in the “Drop Down Menu”. When it’s selected and the user’s “Group” setting different from the Door Settings, one “(1)Open Time Error ”message will be recorded and shown on the Access Log ”screen (referring to the example as below); if the event level equal to or higher than the“ Alarm Trigger Level”, the Relay will be triggered and the E-mail will alert when “ E-mail Alerts ”is configured and one alert e-mail will be sent out.</p> <p>2、When the “Latched Time : 0”, the alert can only be lifted/stopped by clicking “ Alarm OFF ”button on the “Door Status Monitoring/Security Bypass” screen of “Remote Control” function, default level = 0.</p>
<p>Expired User</p>	<p>1、It will be listed in the “Drop Down Menu”. When it’s selected and the user’s “Expiry Date” overdue, one “(1)EXPIRED ”message will be recorded and shown on the Access Log ”screen (referring to the example as below); if the event level equal to or higher than the“ Alarm Trigger Level”, the Relay will be triggered and the E-mail will alert when “ E-mail Alerts ”is configured and one alert e-mail will be sent out.</p> <p>2、When the “Latched Time : 0”, the alert can only be lifted/stopped by clicking “ Alarm OFF ”button on the “Door Status Monitoring/Security Bypass” screen of “Remote Control” function, default level = 0.</p>

<p>Anti Pass Back Violation</p>	<p>1、It will be listed in the “Drop Down Menu”. When it’s selected and the doors with “Anti Pass Back Level ”configuration, one “(1)ANTI_PB REJ ”message will be recorded and shown on the Access Log ”screen (referring to the example as below); if the event level equal to or higher than the“ Alarm Trigger Level”, the Relay will be triggered and the E-mail will alert when “ E-mail Alerts ”is configured and one alert e-mail will be sent out.</p> <p>2、When the “Latched Time : 0”, the alert can only be lifted/stopped by clicking “ Alarm OFF ”button on the “Door Status Monitoring/Security Bypass” screen of “Remote Control” function, default level = 0. ※ Only 1 Door (2 way) is supported with this function.</p>
<p>Door open too long</p>	<p>1、It will be listed in the “Drop Down Menu”. When it’s selected and the door closes over the time set after the user card being scanned, one “(O)Open too long ”message will be recorded and shown on the Access Log ”screen (referring to the example as below); if the event level equal to or higher than the“ Alarm Trigger Level”, the Relay will be triggered and the E-mail will alert when “ E-mail Alerts ”is configured and one alert e-mail will be sent out.</p> <p>2、When the “Latched Time : 0”, the alert can only be lifted/stopped by clicking “ Alarm OFF ”button on the “Door Status Monitoring/Security Bypass” screen of “Remote Control” function, default level = 0.</p>
<p>Door Intruded</p>	<p>1、It will be listed in the “Drop Down Menu”. When it’s selected and the door is accessed forcibly and abnormally, one “(O) DOOR INTRUDED ” message will be shown on the Access Log ”screen (referring to the example as below); if the event level equal to or higher than the “ Alarm Trigger Level”, the Relay will be triggered and the E-mail will alert when “ E-mail Alerts ”is configured and one alert e-mail will be sent out.</p> <p>2、When the “Latched Time : 0”, the alert can only be lifted/stopped by clicking “ Alarm OFF ”button on the “Door Status Monitoring/Security Bypass” screen of “Remote Control” function, default level = 4.</p>
<p>Duress Alarm On</p>	<p>1、It will be listed in the “Drop Down Menu”. When it’s selected and the “Duress Alarm ”of a door is triggered by the user (note : you have to key in the “Anti Duress Password” and press “ENT ”before scanning the user card), one “ANTI DURESS” message will be shown on the Access Log ”screen; if the event level equal to or higher than the “ Alarm Trigger Level”, the Relay will be triggered and the E-mail will alert when “ E-mail Alerts ”is configured and one alert e-mail will be sent out.</p> <p>2、When the “Latched Time : 0”, the alert can only be lifted/stopped by clicking “ Alarm OFF ”button on the “Door Status Monitoring/Security Bypass” screen of “Remote Control” function, default level = 4.</p>
<p>Fire Alarm On</p>	<p>1、It will be listed in the “Drop Down Menu”. When it’s selected and if the “Fire Alarm ”is triggered, one “FIRE ALARM” message will be recorded and shown on the Access Log ”screen; if the event level equal to or higher than the “ Alarm Trigger Level”, the Relay will be triggered and the E-mail will alert when “ E-mail Alerts ”is configured and one alert e-mail will be sent out.</p> <p>2、When the “Latched Time : 0”, the alert can only be lifted/stopped by clicking “ Alarm OFF ”button on the “Door Status Monitoring/Security Bypass” screen of “Remote Control” function, default level = 5.</p>

◆ Multi Badge Group

Select and Click "Multi Badge Group" on the left side of the Main Window, you'll see the "Multi Badge Group" screen as below:

Multi Badge Group

Multi Badge Group	User ID 1	User ID 2	User ID 3
1.	<input type="text"/>	<input type="text"/>	<input type="text"/>
2.	<input type="text"/>	<input type="text"/>	<input type="text"/>
3.	<input type="text"/>	<input type="text"/>	<input type="text"/>
4.	<input type="text"/>	<input type="text"/>	<input type="text"/>
5.	<input type="text"/>	<input type="text"/>	<input type="text"/>
6.	<input type="text"/>	<input type="text"/>	<input type="text"/>
7.	<input type="text"/>	<input type="text"/>	<input type="text"/>
8.	<input type="text"/>	<input type="text"/>	<input type="text"/>
9.	<input type="text"/>	<input type="text"/>	<input type="text"/>
10.	<input type="text"/>	<input type="text"/>	<input type="text"/>
<input type="button" value="set"/>			

◆ Illustration of Multi Badge Group

► Multi Badge Group	
Multi Badge Group	Max. 10 Groups to be set.
User ID 1	Enter the User ID 1 for Multi Badge Group.
User ID 2	Enter the User ID 2 for Multi Badge Group.
User ID 3	Enter the User ID 3 for Multi Badge Group.
Set (button)	Save all the configurations.

➤ Tools

◆ IP Camera

Select "IP Camera" on the left side of the Main Window, you'll see the "IP Camera" screen as the following example:

IP Camera(IP)	PORT	TYPE	username (30 Char. Max)
1. 0.0.0.0	80	VIVOTEK IP7133/7330	
2. 0.0.0.0	80	VIVOTEK IP7133/7330	
3. 0.0.0.0	80	VIVOTEK IP7133/7330	
4. 0.0.0.0	80	VIVOTEK IP7133/7330	

Door 1

Door 2

Door 3

Door 4

◆ Illustration of IP Camera

▶ IP Camera	
IP Camera 1	Enter the IP address of IP Camera 1 to be lined.
IP Camera 2	Enter the IP address of IP Camera 2 to be lined.
IP Camera 3	Enter the IP address of IP Camera 3 to be lined.
IP Camera 4	Enter the IP address of IP Camera 4 to be lined.
Door 1	Display the captured and the most updated picture of Door 1.
Door 2	Display the captured and the most updated picture of Door 2.
Door 3	Display the captured and the most updated picture of Door 3.
Door 4	Display the captured and the most updated picture of Door 4.
Set (button)	Save all the configurations.
Refresh (button)	Refresh the WEB page of IP Camera.

◆ Backup

SEMAC-D system can be backup for restore to system again by selecting:
Database/User Data/User list, as below:

Backup

Tips :

This command will export the User Registry data for backup purpose.

Database(database.cfg) User Data(userdata.cfg) User List(userlist.txt)

BACKUP

◆ Restore

SEMAC-D system can be backup and restore to SEMAC-D again. Only Database/User List available.

RESTORE / IMPORT

Select a File to Restore / Import :

瀏覽...

Database(database.cfg/userdata.cfg) User List(userlist.txt)

(It may takes few minutes to restore the database.)

Restore

◆ Reboot

Select "Reboot" on the left side of the Main Window, you'll see the "Reboot System" screen as below:

Reboot System

REBOOT

◆ Illustration of Reboot

► Button

Reboot	Reboot the SEMAC-D4, similar to warm boot a computer.
--------	---

◆ Upgrade Firmware

Select "Upgrade FIRMWARE" on the left side of the Main Window, you'll see the "FIRMWARE UPGRADE" screen as below:

FIRMWAVE UPGRADE

Warning: Upgrade must NOT be interrupted

Please select a file to upgrade : 瀏覽...

UPGRADE

◆ Illustration of Upgrade Firmware

► Steps

Press button "Browse" to search your firmware to be upgraded.

Press button "Upgrade" to execute the firmware upgrade action.

► Note

Please upgrade the "System Code" first then upgrade "WEB code".

◆ Reset

Select "Reset" on the left side of the Main Window, you'll see the "Reset" screen as below:

Reset

User Data
 Access Logs
 Group
 Time Zone
 Time Set
 Holiday
 System Logs

Reset System to Factory Default -

◆ Illustration of Reset

▶ Data Reset	
User Data	Tick the box before "User Data" and Click "Delete" button to delete all the User Data.
Access Log	Tick the box before "Access Log" and Click "Delete" button to delete all the Access Logs.
Group	Tick the box before "Group" and Click "Delete" button to delete all the Groups.
Time Zone	Tick the box before "Time Zone" and Click "Delete" button to delete all the Time Zone configurations.
Time Set	Tick the box before "Time Set" and Click "Delete" button to delete all the Time Set configurations.
Holiday	Tick the box before "Holiday" and Click "Delete" button to delete all the Holiday configurations.
System Logs	Tick the box before "System Logs" and Click "Delete" button to delete all the System Logs.
▶ Button	
Select All	Tick the box before above item.
Delete	Delete above item(s) selected.
Steps :	
1、Tick the item above to be deleted.	
2、Click button "Delete".	
▶ Reset System to Factory Default	
Factory Default	Execute this command to restore the system back to the factory default.